

This obsolete manual file is provided as a courtesy to you by Ten-Tec, Inc.

Ten-Tec's service department can repair and service virtually everything we have built going back to our first transceivers in the late 1960's. It is our ability to continue offering service on these rigs that has led to their re-sale value remaining high and has made a major contribution to our legendary service reputation.

Printed and bound copies of all manuals are available for purchase through our service department if you would prefer not to use this copy as your transceiver manual.

We can repair or service your Ten-Tec equipment at our facility in Sevierville, TN. We also offer support via telephone for all products via during usual business hours of 8 a.m. to 5 p.m. USA Eastern time, Monday through Friday. We have a large supply of parts for obsolete products. Repairing a transceiver or amplifier yourself? Contact us for parts pricing information.

**Service department direct line: (865) 428-0364
Ten-Tec office line: (865) 453-7172
Service department email: service@tentec.com
Address: 1185 Dolly Parton Parkway, Sevierville, TN 37862 USA**

We have found it is most effective for us to help you troubleshoot or repair equipment with a consultation via telephone rather than by email.

Suggested contact methods are:

**Troubleshooting or repairing equipment – call (865) 428-0364
Other inquiries – call (865) 428-0364 or email service@tentec.com**

THANK YOU AND 73 FROM ALL OF US AT TEN-TEC

TEN-TEC

**OPERATOR'S
MANUAL**

ARGONAUT II

MODEL 535

DELTA II

MODEL 536

GENERAL COVERAGE HF TRANSCEIVERS

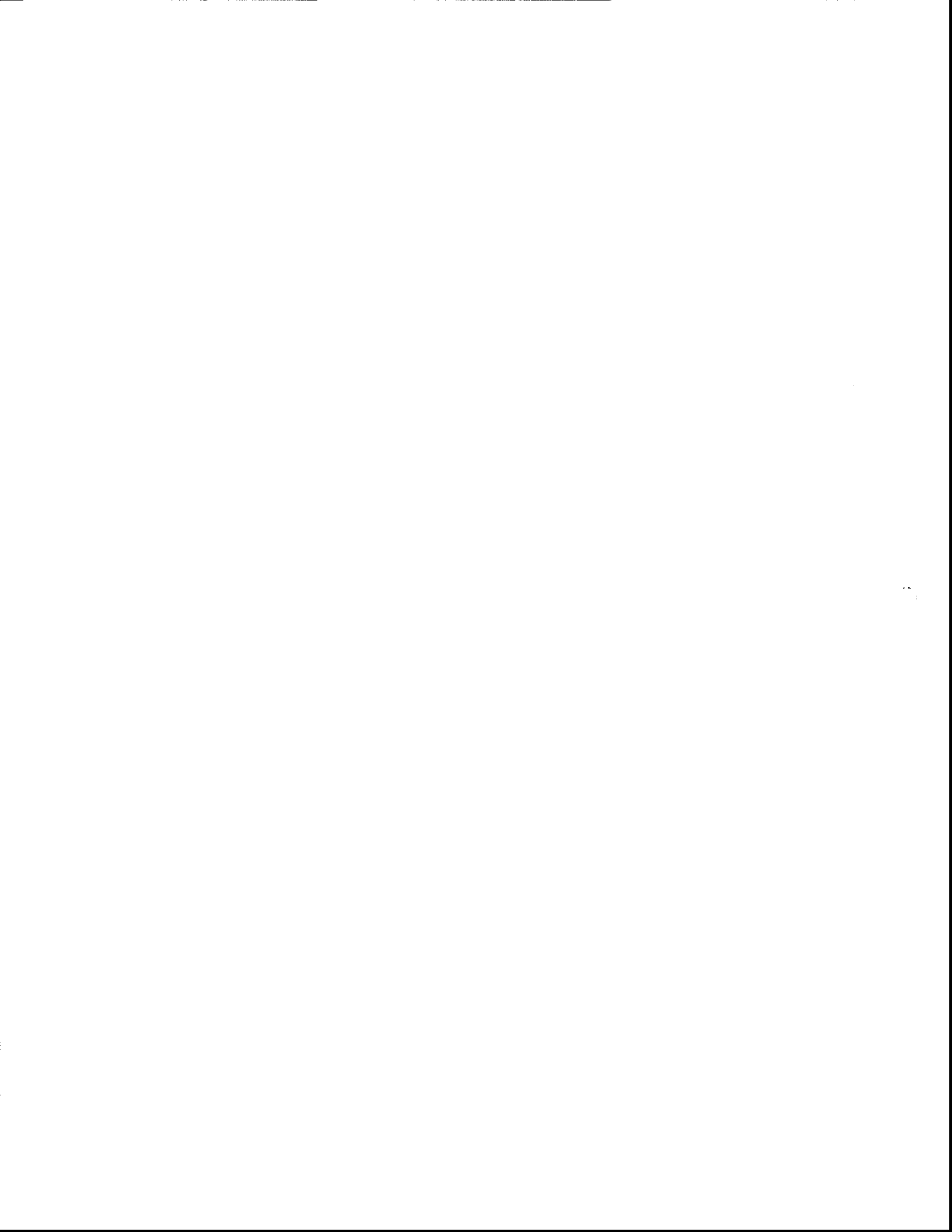

Model 535/536 (Argonaut II / Delta II) Quick Reference Card

FREQUENCY ENTRY:

EXAMPLE – To enter 14.256 MHz [Press **ENTER** 1 4 . 2 5 6 **ENTER**]

EXAMPLE – To enter 14.000 MHz [Press **ENTER** 1 4 . **ENTER**]

If you make a mistake, you can start over by pressing the **CLEAR** key before pressing **ENTER**.

RAPID FREQUENCY CHANGE:

▼ or ▲ – Moves the operating frequency down or up in large steps. If **FAST** is off, the step size is 100 kHz. When **FAST** is on, the step size is 1 MHz.

OPERATING MODES:

←**MODE** Changes the mode selected as shown in the LCD display. If keypad “beep” function is **MODE**→ activated, the first letter of each mode is heard in morse code through the speaker.

TUNE Places transceiver into CW mode and activates transmitter. Same as key down in CW mode. Pressing key a second time returns transceiver to previous receive condition.

RXO Turns receive Offset Tuning on or off. Affects 2nd L.O. only. Provides for ± approx. 1.25 kHz tuning range. Note: RXO is turned off when REV is activated.

FAST Turns on or off Fast Tuning Rate. When on, larger step size will be used for Main Tuning.

VFO CONTROL:

REV Allows reception on alternate VFO frequency(TX) when SPLIT is turned on. With SPLIT off, will key built-in sidetone if CW mode is selected.

A / B Toggles between VFO A and VFO B operating frequencies and modes.

A=B Transfers operating frequency and mode of displayed VFO into alternate VFO.

SPLIT Turns on or off the split operating mode. When on, transmitted frequency will be that of alternate VFO and receive frequency will be that shown in VFO selected during receive.

MEMORY FUNCTIONS:

There are a total of 48 Memory Channels available (00-47). Memory Channels 00-31 are simplex and will hold only one frequency/mode setting. Memory Channels 32-47 are duplex memories and will hold the frequency and mode information for both VFO A and VFO B. In addition, there is a separate ScratchPad Memory which can be used to hold temporary settings without affecting the non-volatile RAM.

VFO>M Prompts operator for 2 digit *Memory Channel* entry. Saves displayed *Frequency* and *Mode* into selected *Memory Channel*.

VFO>M Stores current operating *Frequency* and *Mode* into next available empty *Memory Channel*.
ENTER

VFO>M When pressed twice quickly, stores current *Frequency* and *Mode* into *ScratchPad Memory*.
VFO>M

M>VFO Prompts operator for 2 digit *Memory Channel* entry. Recalls selected *Memory Channel* *Frequency* and *Mode* into current VFO.

M>VFO When pressed twice quickly, recalls *ScratchPad Memory* into current VFO.

M>VFO

M. TUNE Turns Memory Tune function on or off. **M. TUNE** allows you to tune through active Memory Channels using the Main Tuning Knob. If **MSM** is turned on, you will hear each new Memory Channel as it is displayed. If **MSM** is off, only the LCD display will change.

CLEAR When **M.TUNE** is turned on, this key will *Clear* the displayed Memory Channel.

MASTER CLEAR – To *Clear ALL Memories*, depress the **CLEAR** key while turning on the **POWER** switch, then release the **CLEAR** key.

F, REV Toggles the MSM annunciator and function on or off. (See **M.TUNE** above for use.)

SHIFTED FUNCTIONS: (All Shifted Functions are accessed by first pressing the F key)

F, REV Toggles the MSM annunciator and function on or off. (See **M.TUNE** above for use.)

F, <MODE Activates the transceiver Address Selection routine for use in serial remote control of transceiver. This address is factory preset to 64. See manual for further information.

F, MODE> Toggles the Ham/General Transceive function on or off. See manual for explanation.

F, TUNE Toggles the keypad “beep” tone on or off. When turned on, each keypad button closure will cause a beep or beeps to be heard in the speaker. The amplitude is controlled by the **S.T. VOL** setting. When the beep function is on, the *MODE CW IDENTIFIER* is also turned on.

F, M.TUNE Lock which when turned on, prevents the Main Tuning Knob from changing the operating frequency of the transceiver. **LOCK** annunciator is shown in LCD display and keypad remains active.

F, ▼ or ▲ – Adjusts operating band down or up, respectively, from present position. Transfers to next valid Ham Band segment.

CLOCK FUNCTIONS:

SETTING THE CLOCK –

To set the Clock press: **F, FAST (SET CLK)**

The current time will be displayed and the hours and tens of hours digits will start blinking. Press either ▼ or ▲ keys to change the hours reading. When the desired hours value is displayed, press **ENTER**. The minutes and tens of minutes digits will start blinking. Press either ▼ or ▲ keys to change the minutes reading. When the desired minutes value is displayed, press **ENTER** and the clock will begin counting from the new value.

SOFT CONTROLS:

F, RXO (S.T. VOL) – Keys sidetone oscillator and shows current level on LCD meter scale. **C.SET** annunciator starts blinking, indicating that a soft control function is selected for adjustment. Use the ▼ or ▲ keys to adjust the value to the level desired, then press **ENTER** to save the new value.

F, VFO>M (VOX GAIN) – Adjusts VOX Gain circuit in real time and allows operator to use the ▼ or ▲ keys to set desired value. Pressing the **ENTER** key save new value and returns transceiver to normal function.

F, ENTER (VOX DLY) – Adjusts VOX Delay circuit in real time and allows operator to use the ▼ or ▲ keys to set desired value. Pressing the **ENTER** key save new value and returns transceiver to normal function.

F, M>VFO (ANTIVOX) – Adjusts VOX Feedback (antivox) circuit in real time and allows operator to use the ▼ or ▲ keys to set desired value. Pressing the **ENTER** key save new value and returns transceiver to normal function.

TABLE OF CONTENTS

<u>PARAGRAPH</u>	<u>PAGE</u>
LIST OF ILLUSTRATIONS	iii
LIST OF TABLES	v
INTRODUCTION	vi
UNPACKING	vi
SPECIFICATIONS	vii
1. INSTALLATION	
1-1 INTRODUCTION	1-1
1-2 FIXED STATION & MOBILE	1-1
1-3 POWER SUPPLY	1-1
1-4 ANTENNAS	1-2
1-5 MICROPHONE	1-2
1-6 KEY 1-2	
1-7 GROUND	1-2
1-8 BATTERY BACKUP	1-2
1-9 MODEL 535/536 ACCESSORIES	1-3
1-10 EXTERNAL LINEAR AMPLIFIER	1-3
2. OPERATING INSTRUCTIONS	
2-1 POWERING UP THE TRANSCEIVER	2-1
2-2 TUNING THE TRANSCEIVER	2-1
2-2.1 MAIN TUNNING KNOB	2-1
2-2.2 TUNNING FROM THE KEYPAD	2-2
2-2.3 RECEIVE OFFSET TUNNING	2-2
2-3 SELECTING MODE	2-3
2-3.1 RECEIVING IN CW	2-3
2-3.2 USING THE TUNE FUNCTION	2-3
2-4 USING THE DUAL VFO'S	2-3
2-4.1 SELECTING A VFO	2-3
2-4.2 USING SPLIT VFO'S	2-3
2-5 MEMORIES	2-3
2-5.1 USING THE SCRATCH PAD	2-3
2-5.2 STORING TO MEMORY	2-4
2-5.3 RECALLING FROM MEMORY	2-4
2-5.4 USING MEMORY TUNE	2-4
2-5.5 CLEARING MEMORIES	2-4



TABLE OF CONTENTS (continued)

<u>PARAGRAPH</u>	<u>PAGE</u>
2-6 SPECIAL KEYPAD FUNCTIONS	2-4
2-6.1 SETTING THE SIDETONE LEVEL	2-4
2-6.2 SETTING THE VOX	2-5
2-6.3 SETTING THE CLOCK	2-5
2-6.4 TRANSMITTER FREQUENCY COVERAGE	2-5
2-7 FRONT PANEL CONTROLS	2-5
2-7.1 AF/RF GAIN	2-5
2-7.2 PBT/IF BW	2-5
2-7.3 RXO/NOTCH	2-6
2-7.4 MIC/PWR	2-6
2-7.5 PROC	2-6
2-7.6 FWD/SWR METER SWITCH	2-7
2-7.7 VOX SWITCH	2-7
2-7.8 NOISE BLANKER	2-7
2-8 FRONT PANEL CONNECTIONS	2-7
2-8.1 MIC	2-7
2-8.2 PHONES	2-7
2-9 TOP PANEL SWITCHES	2-7
2-9.1 QSK FAST/SLOW	2-7
2-9.2 AGC FAST/SLOW, ON/OFF	2-7
2-9.3 ATTN -20dB/OFF	2-7
2-9.4 LAMP ON/OFF	2-7
2-9.5 SQL ON/OFF	2-8
2-10 REAR PANEL	2-8
2-10.1 ANT	2-8
2-10.2 POWER 13.6	2-8
2-10.3 FUSE	2-8
2-10.4 CW KEY	2-8
2-10.5 AUX DC	2-8
2-10.6 GROUND POST	2-8
2-10.7 J-3 SERIAL INTERFACE PORT	2-8
2-10.8 ATTENUATOR LOOP	2-8
2-10.9 SPKR	2-8
2-10.10 FAN	2-9
2-10.11 J1 ACCESSORY JACK	2-9
2-10.12 J2 BAND LINE OUTPUTS	2-12

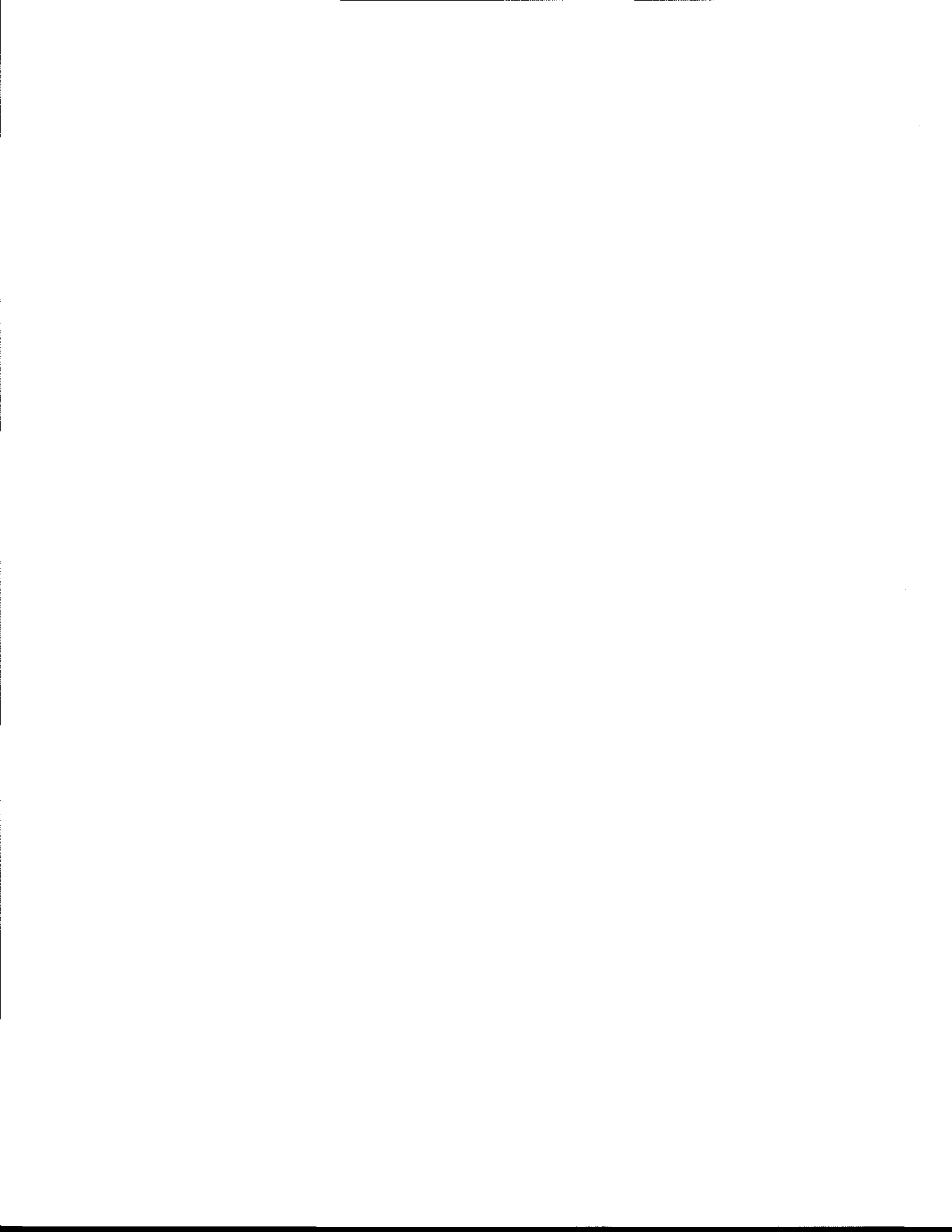

TABLE OF CONTENTS (continued)

<u>PARAGRAPH</u>	<u>PAGE</u>
3. OPERATING HINTS	
3-1 INTRODUCTION.....	3-1
3-1.1 CW	3-1
3-1.2 FM.....	3-1
3-1.3 PROTECTIVE CIRCUITRY & ALC	3-1
3-1.4 SOLID STATE POWER AMPLIFIERS	3-1
3-1.5 BROADBAND vs RESONANT TANKS	3-2
3-1.6 SWR - Two Kinds.....	3-2
3-1.7 EFFICIENCY	3-3
4. CIRCUIT DESCRIPTIONS AND ILLUSTRATIONS	
4-1 INTRODUCTION	4-1
4-2 KEYPAD BOARD (81499).....	4-2
4-3 LOGIC BOARD (81500)	4-3
4-4 LCD DISPLAY BOARD (81501)	4-7
4-5 5 WATT POWER AMPLIFIER (81502)	4-9
4-6 DELTA II 100 WATT AMPLIFIER BOARD(81503)	4-11
4-7 TRANSMIT AUDIO BOARD (81506)	4-13
4-8 TRANSMITT MIXER BOARD(81507).....	4-16
4-9 DELTA II LOWPASS FILTER BOARD(81508)	4-19
4-10 SLIDE SWITCH BOARD(81518).....	4-22
4-11 PUSHBUTTON SWITCH BOARD(81520)	4-23
4-12 ARGONAUT II TRANSMIT LOWPASS FILTER BOARD (81521)	4-24
4-13 UPPER POT BOARD(81522).....	4-26
4-14 LOWER POT BOARD(81523)	4-27
4-15 SECOND MIXER / NOISE BLANKER (81524)	4-28
4-16 IF / AF BOARD (81525)	4-30
4-17 BAND PASS FILTER / FIRST MIXER (81526)	4-34
4-18 RECEIVE SECOND IF BOARD (81527)	4-36
4-19 FIRST L.O. BOARD (81528)	4-38
4-20 SECOND L.O. BOARD (81529)	4-40
4-21 BFO BOARD (81530)	4-42
4-22 CONTROL BOARD (81531)	4-44
4-23 VARIABLE BANDWIDTH CRYSTAL FILTER (81532).....	4-46
4-24 AM CRYSTAL FILTER BOARD (81533)	4-48
4-25 NOISE BLANKER / FM BOARD (81544)	4-49



LIST OF ILLUSTRATIONS

<u>FIGURE</u>	<u>PAGE</u>
1-1 POWER SUPPLY CONNECTIONS	1 1
1-2 POWER SUPPLY ADAPTER CABLE	1-1
2-1 MIC CONNECTIONS	2-7
2-2 ACCESSORY JACK J1	2-9
2-3a CONNECTION OF DELTA II TO TEN-TEC AMPLIFIER	2-11
2-3b CONNECTION OF DELTA II TO NON QSK AMPLIFIER	2-11
2-4 ACCESSORY JACK J2	2-12
2-5a CONNECTION FOR REMOTE BANDSWITCH CONTROL OF 420 OR 253 BY DELTA II	2-13
2-5b CONNECTION FOR REMOTE BANDSWITCH CONTROL OF 420 AND 253 BY DELTA II	2-13
3-1 MODEL 535 FRONT PANEL	3-5
3-2 MODEL 535 REAR PANEL	3-5
3-3 MODEL 535 TOP VIEW	3-6
3-4 MODEL 535 BOTTOM VIEW	3-7
3-5 MODEL 536 FRONT PANEL	3-8
3-6 MODEL 536 REAR PANEL	3-8
3-7 MODEL 536 TOP VIEW	3-9
3-8 MODEL 536 BOTTOM VIEW	3-10
4-1 81499 KEYPAD BOARD COMPONENT LAYOUT	4-2
4-2 81499 KEYPAD BOARD SCHEMATIC	4-2
4-3 81500 LOGIC BOARD COMPONENT LAYOUT	4-5
4-4 81500 LOGIC BOARD SCHEMATIC	4-6
4-5 81501 LCD DISPLAY COMPONENT LAYOUT	4-7
4-6 81501 LCD DISPLAY SCHEMATIC	4-8
4-7 81502 5 WATT POWER AMPLIFIER COMPONENT LAYOUT	4-9
4-8 81502 5 WATT POWER AMPLIFIER SCHEMATIC	4-10
4-9 81503 DELTA II 100 WATT AMPLIFIER COMPONENT LAYOUT	4-11
4-10 81503 DELTA II 100 WATT AMPLIFIER SCHEMATIC	4-12
4-11 81506 TRANSMIT AUDIO BOARD COMPONENT LAYOUT	4-14
4-12 81506 TRANSMIT AUDIO BOARD SCHEMATIC	4-15
4-13 81507 TRANSMITT MIXER COMPONENT LAYOUT	4-17
4-14 81507 TRANSMITT MIXER SCHEMATIC	4-18
4-15 81508 DELTA II LOWPASS FILTER COMPONENT LAYOUT	4-19
4-16 81508 DELTA II LOWPASS FILTER SCHEMATIC	4-20
4-17 81516 DELTA II ACCESSORY CONNECTOR SCHEMATIC	4-21
4-18 81517 DELTA II PHONO CONNECTOR SCHEMATIC	4-21
4-19 81518 SLIDE SWITCH BOARD COMPONENT LAYOUT	4-22
4-20 81518 SLIDE SWITCH BOARD SCHEMATIC	4-22



LIST OF ILLUSTRATIONS(continued)

<u>FIGURE</u>	<u>PAGE</u>
4-21 81520 PUSHBUTTON SWITCH BOARD COMPONENT LAYOUT	4-23
4-22 81520 PUSHBUTTON SWITCH BOARD SCHEMATIC	4-23
4-23 81521 ARGONAUT II TRANSMIT LOWPASS FILTER COMPONENT LAYOUT	4-24
4-24 81521 ARGONAUT II TRANSMIT LOWPASS FILTER SCHEMATIC	4-25
4-25 81522 UPPER POT BOARD COMPONENT LAYOUT	4-26
4-26 81522 UPPER POT BOARD SCHEMATIC	4-26
4-27 81523 LOWER POT BOARD COMPONENT LAYOUT	4-27
4-28 81523 LOWER POT BOARD SCHEMATIC	4-27
4-29 81524 SECOND MIXER / NOISE BLANKER COMPONENT LAYOUT	4-28
4-30 81524 SECOND MIXER / NOISE BLANKER SCHEMATIC	4-29
4-31 81525 IF / AF BOARD COMPONENT LAYOUT	4-32
4-32 81525 IF / AF BOARD SCHEMATIC	4-33
4-33 81526 BAND PASS FILTER / FIRST MIXER COMPONENT LAYOUT	4-34
4-34 81526 BAND PASS FILTER / FIRST MIXER SCHEMATIC	4-35
4-35 81527 RECEIVE SECOND IF BOARD COMPONENT LAYOUT	4-36
4-36 81527 RECEIVE SECOND IF BOARD SCHEMATIC	4-37
4-37 81528 FIRST L.O. BOARD COMPONENT LAYOUT	4-38
4-38 81528 FIRST L.O. BOARD SCHEMATIC	4-39
4-39 81529 SECOND L.O. BOARD COMPONENT LAYOUT	4-40
4-40 81529 SECOND L.O. BOARD SCHEMATIC	4-41
4-41 81530 BFO BOARD COMPONENT LAYOUT	4-42
4-42 81530 BFO BOARD SCHEMATIC	4-43
4-43 81531 CONTROL BOARD COMPONENT LAYOUT	4-44
4-44 81531 CONTROL BOARD SCHEMATIC	4-45
4-45 81532 VARIABLE BANDWIDTH CRYSTAL FILTER COMPONENT LAYOUT	4-46
4-46 81532 VARIABLE BANDWIDTH CRYSTAL FILTER SCHEMATIC	4-47
4-47 81533 AM CRYSTAL FILTER COMPONENT LAYOUT	4-48
4-48 81533 AM CRYSTAL FILTER SCHEMATIC	4-48
4-49 81544 NOISE BLANKER / FM BOARD COMPONENT LAYOUT	4-49
4-50 81544 NOISE BLANKER / FM BOARD SCHEMATIC	4-50

LIST OF TABLES

<u>TABLE</u>	<u>PAGE</u>
2-1 TUNING RATES	2-2
2-2 J1 ACCESSORY JACK PIN DESCRIPTIONS	2-10
3-1 TROUBLE SHOOTING CHART	3-4



It shouldn't feel like work.



OMNI-VII. It's that simple.

So sit back in your chair and relax. The Omni-VII not only has top of the line receiver performance and everything else you need in a high-end transceiver -- it's also very easy to use. Spend your time on the air instead of reading the operator's manual. For complete information on the Omni-VII and our Amateur Radio product line, visit our website or call (800) 833-7373 for our current catalog.

Proudly made in Sevierville, Tennessee USA

TEN-TEC
www.tentec.com

1185 Dolly Parton Pkwy., Sevierville, TN 37862. Sales: 800-833-7373 M-F 8:00-5:30 (Eastern Time) sales@tentec.com. Office: (865) 453-7172. FAX: (865) 428-4483. Service: (865) 428-0364 M-F 8:00-5:00 (Eastern Time), service@tentec.com. We accept Visa, MC, American Express and Discover.

INTRODUCTION

The Model 535/536 is a microprocessor controlled HF transceiver incorporating world class receiver performance and the latest digital technology. The Model 535/536 features a fully synthesized PLL design which provides general coverage from 100 kHz to 29,999 MHz. The Model 535/536 also provides a large easy to read backlit LCD display, dual digital VFOs, tunable I-F filter system, 48 nonvolatile RAM memories (32 simplex and 16 duplex), memory tune via the main tuning knob, built-in 24 hour clock and all solid state design including the broadband "no tune" final power amplifier.

The Model 535/536 covers all amateur bands using CW (with full or semi break-in), SSB (with built-in speech processor), RTTY (AFSK) and FM. General coverage receive includes AM.

Chapter 1 of this manual covers installation of the transceiver. Chapter 2 provides a detailed description of the Model 535/536 features, controls, and operation. Chapter 3 provides additional information to help you get the best performance out of your transceiver. Chapter 3 also contains a trouble-shooting guide. Chapter 4 is the technical reference section and contains detailed circuit descriptions and illustrations as well as schematic diagrams.

UNPACKING

Examine your Model 535/536 for signs of shipping damage. Should any damage be apparent, notify the delivering carrier or dealer immediately, stating the full extent of the damage. Retain all damaged cartons. Liability for shipping damage rests with the carrier.

It is recommended that you keep the shipping carton and fillers in the event that storage, moving or reshipment becomes necessary. The following hardware and accessories are packed with your DELTA II. Make sure that you have not overlooked anything.

1-27045	Fuse-Fast Blo 25A
1-35240	7 Pin DIN Connector
1-#35165	2 Pin Connector Shell
1-#38040	.050" Allen Wrench
1-#38088	.062" Allen Wrench
2-#41020	Female Terminal Pins
1-#74020	Warranty Card
1-#74212	Operator's Manual
1-#86034-66	Power Cable

The following hardware and accessories are packed with your ARGONAUT II. Make sure that you have not overlooked anything.

1-27015	Fuse-Slo Blo 4A
1-#35165	2 Pin Connector Shell
1-#38040	.050" Allen Wrench
1-#38088	.062" Allen Wrench
2-#41020	Female Terminal Pins
1-#74020	Warranty Card
1-#74212	Operator's Manual
1-#86034-66	Power Cable

If any of the above items are missing, contact the customer service department at Ten-Tec for replacements:

Customer Service	615-428-0364
Switchboard	615-453-7172
FAX	615-428-4483



Model 535/536 SPECIFICATIONS

GENERAL

FREQUENCY RANGE	Receive: 100 kHz to 29.999.99 MHz Transmit: 1.8 to 29.999.99MHz
FREQUENCY CONTROL	Microprocessor controlled digital PLL synthesizer. 10 Hz resolution.
FREQUENCY READOUT	7 digit 10 Hz backlit LCD readout. Also displays time, RXO, memories, modes and S-meter.
FREQUENCY STABILITY	Worst case, 1 PPM per degree C at 29.999MHz.
FREQUENCY ACCURACY	$\pm 100\text{Hz}@25^{\circ}\text{C}$.
MEMORIES	48 total memory channels, 32 Simplex, 16 duplex.
ANTENNA IMPEDANCE	50 ohms unbalanced.
POWER REQUIRED	DELTA II: Receive = approximately 1.0A Transmit = approximately 20A @ 13.8 VDC ARGONAUT II: Recieve = approximately .75A Transmit = approximately 3A @ 13.8 VDC
CONSTRUCTION	Rigid aluminum chassis. Molded ABS Cycolac front panel. Textured top and bottom, snap up stainless steel bail, carrying handle. Printed circuit boards G-10 epoxy glass.
DIMENSIONS	DELTA II-HWD 3.75" x 9.75" x 14" -- (9.53 x 24.77 x 35.56 cm.) ARGONAUT II-HWD 3.75" x 9.75" x 12.50" -- (9.53 x 24.77 x 31.75 cm.)
NET WEIGHT	DELTA II - 12 lbs., 7 oz. -- (5.64 kg.) ARGONAUT II - 8 lbs., 10 oz. -- (3.91 kg.)

TRANSMITTER

MODES	USB, LSB, CW, RTTY (AFSK), and FM.
RF POWER OUTPUT	DELTA II - Zero to 100 watts adjustable with front panel PWR control. ARGONAUT II - Zero to 5 watts adjustable with front panel PWR control.
MICROPHONE INPUT	Four pin front panel connector accepts microphones with 50K ohms or less and with 5 mV (-62 dB) output. Polarizing voltage is available for electret types.
T/R SWITCHING	VOX or PTT
CW SIDETONE	Internally generated, volume is adjustable from keypad and is independent of AF gain control.
SSB GENERATION	Double sideband modulator. 8 pole crystal ladder filter.
CARRIER SUPPRESSION	50dB or more typical.
UNWANTED SIDEBAND SUPPRESSION	45 dB typical at 1.5 kHz tone.
SPURIOUS OUTPUT	More than 45 dB below peak power output.
METER	Switchable forward power (FWD), SWR, S-meter.
CW OFFSET	700 Hz Factory preset.

RECEIVER

MODES USB, LSB, CW, AFSK, AM, FM.

SENSITIVITY	FREQUENCY MHz		
	.1-1.6	1.6-29.999.99	
SSB, CW, AFSK	.50 μ V	0.25 μ V	10 db S/N @ 2.5 kHz
AM	3.50 μ V	1.00 μ V	10 db S/N @ 6.0 kHz
FM	1.00 μ V	.30 μ V	12 db SINAD @ 15 kHz

SELECTIVITY	SELECTIVITY		Shape factor
	-6 dB	-60 dB	
SSB (BW @ MAX)	2.5 kHz	4.9 kHz	2.0:1.0
AM	5.1 kHz	15.8 kHz	3.1:1.0
FM	15.0 kHz	30 kHz @ -30dB	2.0:1.0

CRYSTAL FILTER 8 pole ladder type, "Jones" Filter (Patent # 5051711). Bandwidth continuously adjustable from 2.5kHz to 500 Hz.

ATTENUATOR Approx. -20 dB for 0.1 to 29.999 MHz.

I-F FREQUENCIES 1st = 45 MHz, 2nd = 6.144 MHz, (FM 3rd = 455 kHz).

IMAGE REJECTION > 80dB.

I-F REJECTION > 70dB.

NOISE BLANKER Switchable on/off.

S - METER Automatically switched on during receive. Calibrated to 50 μ V at S9 with attenuator off.

DYNAMIC RANGE 95 dB typical.

NOISE FLOOR -129 dBm. (.25 μ V for +10 dB s/n in ssb)

SQUELCH FM = Less than .6 μ V.
SENSITIVITY

PASS BAND TUNING \pm 2.5 kHz, digitally controlled.

AUDIO OUTPUT 1.5 watts @ 4 ohms with less than 2% distortion.

NOTCH FILTER 250 to 2.2 kHz, 50 dB notch typical.

BFO Digitally controlled PLL.

RECEIVER OFFSET \pm 1.27 kHz (\pm 2.54 kHz when FAST is enabled) digitally controlled with RXO control, unlimited with second VFO.

CHAPTER 1

INSTALLATION

1-1 INTRODUCTION When setting up the station, provide adequate ventilation for the transceiver and the power supply. Do not confine the transceiver and power supply to a small volume without adequate ventilation. When placing the transceiver in a mobile installation, try to keep the transceiver away from high heat sources. Also try to select a location that allows comfortable access to the front panel controls and adequate clearance for rear panel connections.

1-2 FIXED STATION & MOBILE The Model 535/536, with conventional antennas, will perform with distinction in any ham shack.

The Model 535/536 may be used for mobile operation in a car, boat, plane, or other vehicle using the Model 293 Mobile Mount. It operates directly from a 12 to 14 VDC supply source and is self-contained except for key, microphone, tilt bail, and antenna.

NOTE: If the battery voltage drops below 10 volts, the display will start blinking and the Model 535/536 will not operate properly.

The SWR meter is especially useful in setting mobile whip antenna lengths to the operating frequency.

WHEN USING AN ALTERNATOR CHARGED BATTERY, DO NOT START AND STOP THE VEHICLE'S ENGINE WITH THE 535/536 TURNED ON.

High voltage transients, caused by momentarily open regulator contacts, may cause serious damage to the transceiver circuits.

1-3 POWER SUPPLY Use a 12 to 14 VDC negative ground power source capable of delivering 3 amperes (Model 535) or 20 amperes (Model 536), well regulated. When powering from the TEN-TEC Model 935/936 power supply, interconnect units with the cable attached to the power supply.

When other supplies or a battery are used, pin connections to the rear panel mounted power socket are as shown in FIGURE 1-1. Polarity is also indicated directly on the rear panel.

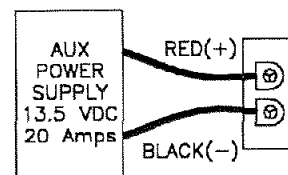

FIGURE 1-1. POWER SUPPLY CONNECTIONS

If you wish to operate the Model 535/536 from a Model 961 power supply, which has a four pin cable connector, an adapter cable (Model #306) must be used as shown in FIGURE 1-2.

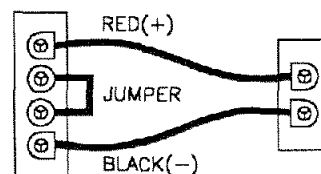

FIGURE 1-2. POWER SUPPLY ADAPTER CABLE (4 Pin to 2 Pin)

1-4 ANTENNAS Any antenna presenting 25 to 75Ω impedance will load satisfactorily. Random length and balanced antennas will require an antenna tuner. Most popular mobile antennas will operate at their resonant frequency without special matching. When they are used as portable antennas, a good ground system or counterpoise should be provided. The Model 535/536 is designed for use with an unbalanced feed system.

Although improper antennas will not damage the final output transistors, it is suggested that an SWR of 2 to 1 or less be achieved for maximum performance. The collector current (Ic) should be less than 3 Amperes for the Model 535 and 20 Amperes for the Model 536 at maximum output power. Be sure to readjust the MIC control after reducing the PWR level.

1-5 MICROPHONE For SSB operation, plug a low impedance dynamic or electret microphone into this jack. Amplified microphones can be used if the output level is adjusted to a low enough value to prevent the microphone circuit from overloading. The Model 535/536 will work with Ten-Tec Model 700 or Model 705 or microphones having an impedance of 200 Ohms to 50k Ohms. See Figure 2-1 for wiring information.

1-6 KEY For CW operation, connect a Model 604, 605, or 606 to this jack. When using electronic keyers, they should be configured for positive keying, not "grid block" or negative. If configured for negative keying, no damage will occur, but the keying circuit will not operate.

1-7 GROUND In the interest of personal safety and to reduce the possibility of stray RF pickup on interconnecting cables which may cause parasitic oscillations, all station equipment should be well grounded to earth. It is also important to strap all equipment chassis

together with short, heavy leads. For the DELTA II the strap between the power supply and the transceiver serves to reduce the voltage drop on the negative lead caused by wire and connector resistance. In mobile installations, connect a ground strap between the rear panel ground lug and the vehicle chassis.

1-8 BATTERY BACKUP The Model 535/536 uses a factory installed 3 VDC lithium battery (Panasonic CR2032 or Mallory DL2032) to maintain the clock memory. Typical life is 3 to 5 years.

To replace the 3 VDC lithium battery, turn the power switch off and proceed as follows:

- STEP 1 Remove the top and bottom covers.
- STEP 2 There are four screws that fasten the front panel to the chassis. Remove the upper left and upper right flat head screws.
- STEP 3 Tilt the front panel down allowing access to the battery.
- STEP 4 There is a two pin jumper plug immediately to the right of the battery holder. Remove this plug.
- STEP 5 Slide the old battery out of its holder. Wipe the new battery clean of any oil or finger prints and slide the new battery into place.
- STEP 6 Turn the power switch on and reinsert the jumper plug.
- STEP 7 Turn the power switch off.
- STEP 8 Replace the two flat head screws removed in step 2.
- STEP 9 Replace the top and bottom covers.
- STEP 10 Check the operation of the transceiver. If you encounter a problem try pushing the reset button.

1-9 535/536 ACCESSORIES

These are the available accessories common to both the 535/536.

Model

- 291---- Portable/Mobile 200 watt antenna tuner
- 293---- Mobile Mount
- 305---- RS-232 Serial Level converter
- 306---- Plug adaptor, 4-pin power supplies to 2-pin 535/536
- 606---- Low Current Curtis Chip Keyer
- 700C -- Hand Microphone
- 705---- Desk Microphone
- 35057-- 4-pin mic plug
- 35165-- 2-pin connector shell
- 41020-- Female pin (2 needed)

In addition to the above these accessories are available for your Model 535 ARGONAUT II.

Model

- 290---- Step Attenuator, steps power from 5W to 10mW
- 935---- 12V, 3A Power Supply, 120/240VAC input

In addition to the above these accessories are available for your Model 536 DELTA II.

Model

- 264---- Remote Control Cable, 536 to 420 and 253 (w/ 268)
- 268---- Remote Control Cable, 536 to 420 or 253
- 269---- QSK Linear Switching Cable, 536 to 420,422, or 425
- 303---- Fan Kit for full power FM and RTTY modes
- 304---- Auxilary RCA type phono connectors to simplify use of J-1 on rear panel
- 936---- 20V, 20A Power Supply, 120/240VAC input
- 1140--- 20A circuit breaker for mobile use (w/connectors)

1-10 EXTERNAL LINEAR AMPLIFIER

Refer to section 2-10.11, figure 2-3a, and figure 2-3b for details on the connection of the Model 536 to amplifiers available from Ten-Tec or other manufacturers.



CHAPTER 2

OPERATING INSTRUCTIONS

2-1 POWERING UP THE TRANSCEIVER This chapter describes the various controls and features of the Model 535/536 transceivers. Once the unit has been properly installed you are ready to become familiar with its operation. Before powering up the transceiver, set all controls and switches as shown below:

FRONT PANEL

AF ----- 9:00
RF ----- Max CW
MIC ----- Max CCW
PWR ----- Max CCW
RXO ----- 12:00
NOTCH -- Max CW
PBT ----- 12:00
IF BW ---- Max CW
METER --- FWD
PROC ----- OFF (Switch out position)
N.B. ----- OFF
VOX ----- OFF

TOP PANEL

QSK ----- FAST
AGC ----- FAST
AGC ----- ON
ATTN ----- OFF
LAMP ---- ON
SQL ----- OFF

REAR PANEL

J1-- On the DELTA II the supplied jumper plug must be installed to transmit.

Turn on the unit by pushing the POWER button. The transceiver will come on in the same condition that it was last used. A factory installed lithium battery retains the mode and frequency settings that were last used during final burn-in at the factory.

As you familiarize yourself with the Model 535/536, and it should fail to operate normally, refer to the troubleshooting chart table 3-1 on page 3-4.

2-2 TUNING THE TRANSCEIVER

Several methods can be used to select the desired operating frequency. The main tuning knob is used most often when tuning within a band. Keypad commands are more convenient when moving between bands. Both methods are described below.

2-2.1 MAIN TUNING KNOB The knob is adjustable so you may select the amount of drag or tension desired. To adjust, hold the outer chrome dial skirt ring with one hand and turn the rubber portion of the knob clockwise with the other hand. About 1/8 turn will increase drag considerably.

Except for AM and FM modes the tuning increment is in 10 Hz steps and each revolution of the tuning knob is approximately 5 KHz of travel. A faster tuning rate can be selected from the keypad which increases the tuning steps to 50 Hz and is approximately 25 KHz per revolution. To select this fast rate push the FAST button and observe that the "FAST" annunciator appears at the right side of the display. Push FAST again to return to the normal setting.

The tuning system has an additional speed shift feature which increases the tuning rate automatically when the knob is spun at a fast rate. This feature anticipates when the operator is trying to move across a band quickly and assists by shifting to the larger step size. TABLE 2-1 charts the step sizes for all combinations of modes and tuning rates.

	Normal	Normal Shifted
CW/USB/LSB/FSK	10 Hz	50 Hz
FM	100 Hz	500 Hz
AM	50 Hz	500 Hz
	Fast	Fast Shifted
CW/USB/LSB/FSK	50 Hz	100 Hz
FM	500 Hz	500 Hz
AM	50 Hz	500 Hz

TABLE 2-1

Another feature which may be useful during mobile operation is the tuning lock command. Once a desired frequency has been selected, the tuning knob can be disabled by pushing the keypad sequence **[F]**, **[M. TUNE]**. The "LOCK" annunciator will appear in the display. To exit the lock condition, push **[F]**, **[M. TUNE]** again.

2-2.2 TUNING FROM THE KEYPAD

Another method of moving within a band or between bands rapidly is to use the **[▲]** and **[▼]** buttons or the "ham band" up and down feature. The **[▲]** and **[▼]** keys tune the transceiver in 100 KHz steps or in 1 MHz steps if FAST is selected. If the **[F]** key is pressed first then **[▲]** moves the transceiver up by one ham band. Likewise **[F]** **[▼]** will move the transceiver down one ham band.

Below many of the keypad buttons are the numbers 0 through 9 and a decimal point. To enter a frequency directly from the keypad, first push the **[ENTER]** button. The frequency display will respond by showing seven dashes

as prompts. Type in the desired frequency by pushing the buttons above each number. The transceiver requires that a decimal be entered between the MHz and 100 KHz digits.

The frequency can be typed in all the way down to the nearest 100 Hz or by pushing **[ENTER]** again and the remaining digits will be filled with zeros.

If an error is made while entering a frequency just push the **[CLEAR]** button to exit the sequence and start again.

Examples:

Desired Frequency	
14.235.00	3.853.30
Press: [ENTER]	Press: [ENTER]
1	3
4	.
.	8
2	5
3	3
5	3
[ENTER]	

Note: In the second example you were not required to press **[ENTER]** again after you entered the 100Hz digit, in this case, the last "3".

2-2.3 RECEIVE OFFSET TUNING

RXO Receive offset tuning is enabled by pushing the **[RXO]** button. The RXO annunciator is now visible in the upper right corner of the display and the clock display becomes an offset frequency indicator. Using the RXO knob, the receiver section of the transceiver can be tuned either above or below the transmit frequency by up to 1.27 KHz or 2.54 KHz in the FAST tuning mode. The indicator shows the amount and direction of the offset.

This function is especially useful for clarifying individual stations on a SSB net or for fine tuning the received note during a CW contact.

2-3 SELECTING MODE The transceiver will operate on all the standard HF modes except AM transmit. Two mode select buttons and scroll through FM, AM, LSB, USB and CW from opposite directions. The current mode is always displayed on the LCD readout. If the keypad beep function is activated, the first character of the mode is sent in morse code using the sidetone.

Note: In FM mode the squelch function may cause the receiver to go completely silent as you shift past that mode.

2-3.1 RECEIVING IN CW In CW receive, there is a factory programmed offset of 700 Hz programmed into the VFO's. This causes a received signal at the displayed frequency to generate a 700 Hz note for the operator to copy. To help the operator judge when the received signal has been tuned to 700 Hz the built in sidetone oscillator has also been preset to 700 Hz. Pushing the button momentarily keys the sidetone oscillator and allows the operator to match the received signal to the pitch of the sidetone.

2-3.2 USING THE TUNE FUNCTION

The button provides an easy way to generate a CW key down condition. With TUNE activated, the readout will indicate both "CW" and "TUNE" and the "TX" annunciator will appear. The transceiver will output a CW carrier at the displayed frequency at a power level determined by the PWR control.

2-4 USING THE DUAL VFO'S For operating versatility, the transceiver has two VFO's (Variable Frequency Oscillators). These can be used separately or in split mode to generate a transmit to receive split in frequency.

2-4.1 SELECTING A VFO The button toggles control of the transceiver be-

tween the A and B VFOs. Each VFO works independently. Changes made to one VFO do not affect the other. Each VFO retains the frequency and mode from the last time it was selected. To net the two VFOs push the button. This will cause the contents of the displayed VFO, either A or B, to be written into the other VFO.

2-4.2 USING SPLIT VFOs Split frequency operation gives the user the freedom of receiving and transmitting on different frequencies. Even the mode of operation can be different between receive and transmit.

To enable split VFO operation push the button. The SPLIT annunciator will appear and the hidden VFO will now control the transmitter frequency and mode.

The hidden transmit VFO can be previewed using the button. This "reverse" button calls up the hidden VFO in receive and lets the operator monitor or change the transmit frequency. This button is momentary so that upon release, the transceiver returns to the receive VFO.

2-5 MEMORIES There are a total of 48 memory channels available (00-47). Memory channels 00-31 are simplex and will hold only one frequency and mode setting. Memory channels 32-47 are duplex memories and will hold the frequency and mode information for both VFO A and VFO B. In addition, there is one separate Scratch Pad Memory which can be used to hold one temporary frequency and mode without affecting the other programmed memories.

2-5.1 USING THE SCRATCH PAD

Information in the active VFO is written to the scratch pad by quickly pushing the button twice. This scratch pad is useful for marking a station or a spot on the band to which you want to return frequently. To recall the scratch pad frequency, quickly push the button twice.

2-5.2 STORING TO MEMORY To store the current frequency and mode in a memory location press the **VFO ► M** key. The clock readout will change to a two digit blinking prompt asking for a memory location number. Enter a two digit number using the keypad buttons to complete the store. If you are unsure of which memories are already filled, press the **ENTER** key instead of a two digit location and the transceiver will store the VFO in the lowest available memory.

When all of the memory locations are occupied the right most decimal point in the frequency readout will come on. When this happens refer to the MEMORY CLEAR procedure to clear out one or more of the memory locations or write over an existing memory.

2-5.3 RECALLING FROM MEMORY

To recall from a memory location press the **M ► VFO** button and enter the desired two digit location when the blinking prompt appears in place of the clock readout. Information from the memory will be transferred into the active VFO.

2-5.4 USING MEMORY TUNE Rather than recall memory locations one at a time, a quick way to step through memories is by using the memory tune feature. The **M. TUNE** button causes the main tuning knob to become a memory channel selector. The main tuning knob will now scroll through the locations and display the frequency and channel number. The receiver does not, however, tune to the displayed frequency unless the **M ► VFO** is pressed. This key will transfer information from the selected memory channel into the active VFO. To exit the memory tune mode press **M. TUNE** again.

There is an alternate memory tuning method that can be selected using another keypad sequence. The "MSM" Memory Scan Mode can be accessed by first selecting

M. TUNE as before and then pressing **F**, **REV**. The "MSM" annunciator will appear above the frequency readout to the left of "MTUNE". In this condition, the receiver will automatically move to each new frequency as the memories are recalled from the tuning knob. Remember that the original status of the active VFO will be lost and the transceiver will remain on the last chosen memory location when you exit M TUNE. This "MSM" mode can be disabled by again pressing **F**, **REV**.

2-5.5 CLEARING MEMORIES Individual memory locations can be cleared by using the M TUNE feature. Press the **M. TUNE** button and scroll through memory locations with the tuning knob. As the unwanted memory locations are displayed press the **CLEAR** button to remove them.

If you wish to clear out all of the memory locations, turn the power switch off and then press and hold the **CLEAR** key. Turn the power switch on and continue to press the **CLEAR** key until the frequency display comes on and shows "15.000.00".

2-6 SPECIAL KEYPAD FUNCTIONS

Many of the analog adjustments that have traditionally been relegated to rear panels or even inside radio equipment are now incorporated into the keypad of the Model 535/536. This feature is important considering that some installations would make these adjustments difficult to change.

2-6.1 SETTING THE SIDETONE

LEVEL To set the sidetone level use the keypad sequence **F**, **RXO**. This will key the sidetone and let you adjust the volume using the **▲** and **▼** keys. The "C.SET" annunciator will blink until you find the desired level. Press **ENTER** to store the setting.

2-6.2 SETTING THE VOX Before the VOX controls can be adjusted the transceiver must be set up for VOX controlled SSB operation. Tune the transceiver to a ham band and select either LSB or USB mode. Turn the MIC control fully counter clockwise and press the front panel VOX button so the VOX indicator light comes on. Now press **[F]**, **[VFO ▶ M]** and speak into your microphone normally. Adjust the VOX gain using the **[▲]** and **[▼]** keys until the transceiver keys reliably. To store the setting press the **[ENTER]** key.

VOX delay should be set so the transceiver does not switch back to receive during the natural pauses in your transmitted speech. To set the delay, push **[F]**, **[ENTER]** and key the VOX by speaking into the microphone. Notice the length of time that the transceiver stays keyed. To shorten the delay use the **[▼]** button or to lengthen the delay use **[▲]**. Once you're comfortable with the setting, press **[ENTER]**.

ANTIVOX is used to counteract the receiver audio that makes its way from the station speaker back into the microphone. To set the ANTIVOX level, press **[F]**, **[M ▶ VFO]** and use the **[▲]** and **[▼]** buttons until moderate receiver audio does not tend to trip the VOX. Store this setting with the **[ENTER]** key.

2-6.3 SETTING THE CLOCK The built-in 24 hour clock uses a 32 KHz watch crystal and is powered from the internal lithium battery. To set the clock, press **[F]** **[FAST]**. The hours digits will blink and can be changed with the **[▲]** and **[▼]** key. When the correct hour digits are set, press **[ENTER]**. Now adjust the blinking minutes digits. Press **[ENTER]** to start the clock from the new value.

2-6.4 TRANSMITTER FREQUENCY COVERAGE As shipped from the factory, the Model 535/536 will transmit only on fre-

quencies authorized for the Amateur Radio Service. If you hold authorization to operate on frequencies outside the Amateur Radio Service, you may defeat this lock-out. Press **[F]** **[MODE ▶]**. There is no indication in the frequency display regarding status of the lock-out. The user is responsible to transmit only within his authorized frequency allocations.

2-7 FRONT PANEL CONTROLS Four dual controls and four switches give the operator full control of transceiver operation. Refer to figure 3-1 (Model 535) or figure 3-5 (Model 536).

2-7.1 AF/RF GAIN The RF gain control selects the amount of gain in the receiver IF stages. Most operators set it full clockwise and rarely reduce it except in cases of extreme receiver overload caused by strong signals. The AF gain controls the audio volume.

2-7.2 PBT/IF BW Selectivity for the Model 535/536 is determined by the eight pole patented "Jones" filter. The IF BW control sets the IF bandwidth from approximately 500Hz at fully counterclockwise to 2500Hz at fully clockwise. In LSB mode, rotation of the IF BW control from the 2500Hz setting towards the 500Hz setting will continually reduce the high frequency response. In the fully counterclockwise position, the audio frequency response will be approximately 200 to 700Hz. When the transceiver is in the USB mode, rotation of the control from the 2500Hz setting will continually reduce the low frequency response. In the full counterclockwise position, the audio frequency response will be approximately 2300Hz to 2800Hz.

The position of any filter bandwidth in any mode with respect to the BFO (actually the received audio spectrum) may be set by the PBT control. For instance, if there is high frequency interference, such as splatter, when

you are on LSB, you can remove the interference by either rotating the PBT control slightly counterclockwise or by rotating the IF BW control slightly counterclockwise. In the first instance you are shifting the passband away from the interference and in the second you are actually reducing the passband to eliminate the interference. If you are in USB with the same interference, rotating the PBT control clockwise will eliminate the splatter. Since, in USB, rotation of the IF BW control will only reduce the low frequency response, this control will not eliminate the interference. In some instances, shifting the passband to eliminate the high frequency splatter may pick up unwanted low frequency interference. In this case, reducing the bandwidth will eliminate the problem.

For optimum performance when receiving CW signals, see section 3-1.1 for additional information on the use of IF-BW control.

NOTE; WHEN YOU CHANGE MODES TO CW OR SSB, DO NOT NEGLECT TO CENTER THE PBT CONTROL TO 12 O'CLOCK.

2-7.3 RXO / NOTCH The NOTCH control adjusts the center frequency of the audio notch across the passband. The notch depth is at least 50 dB and will reduce carrier interference by *this amount or more*. To use the NOTCH, rotate the control slowly until the unwanted signal is reduced. The notch circuit is effectively removed by turning the control fully clockwise in SSB or CW mode. When listening in AM mode, NOTCH should be fully counterclockwise to provide maximum high frequency response.

RXO (receive offset) is selected from the front panel keypad as previously described in paragraph 2-2.3. This knob is normally positioned at 12 o'clock for no offset and can be

turned clockwise or counterclockwise to help clarify received signals. The LCD display indicates the amount of offset either above or below the transmit frequency.

2-7.4 MIC / PWR The PWR control varies the amount of power output for all modes. This allows you to set your peak output power to any value. The MIC control varies the amount of audio applied to the transmit balanced modulator.

To set these controls, place the METER switch in the FWD power position and place the transceiver in transmit using the TUNE function. Advance the PWR control to the desired power level. The power level for CW operation is now set. For SSB operation, while speaking into the microphone in a normal voice, advance the MIC control until the ALC LED lights on voice peaks.

NOTE: THE ALC LED WILL LIGHT AT ALL PWR SETTINGS WHEN OPERATING IN CW OR TUNE MODES.

Increasing the MIC setting over that required to just light the ALC LED on voice peaks will not result in any appreciable increase in power out. However, overdrive will produce SSB, AFSK, or SSTV distortion products. The MIC control has no effect in FM mode.

2-7.5 PROC The PROC switch activates the speech processor. The processor increases the average speech power and allows a greater range of voice levels to attain peak ALC level. An LED above the switch indicates when the processor has been selected.

The speech processor will affect the setting of the MIC control. With the processor turned on, reduce the MIC control as needed to prevent distortion.

Severe distortion, objectionable background noise, and transmitted splatter will occur if the MIC control is not adjusted so that the ALC LED just lights on voice peaks.

2-7.6 FWD/SWR METER SWITCH This switch selects the function of the bar graph meter during transmit. In the FWD position, meter indicates output power with full scale equal to 100 watts output (Model 536) or 5 watts output (Model 535). In SWR position the bar graph indicates reflected power. When three bars on the graph are solid, the SWR is approximately 2:1. As a better match is achieved the third bar will begin flashing then disappear, leaving two bars solid. This represents about 1.5:1 and is an adequate match for most applications. If a lower SWR is desired, continued matching will cause the second bar to flash and then disappear, followed by the first bar. If the first bar disappears the SWR is 1:1.

2-7.7 VOX SWITCH This switch selects either the VOX (voice operated relay) or PTT (push to talk) mode for keying the transceiver. Refer to section 2-6.2 to set up the VOX.

2-7.8 NOISE BLANKER This switch turns on the Noise Blanker. The circuit can reduce troublesome external noise problems from various man-made sources. It will have little or no effect on most naturally occurring noise. It should not be left on except when required to reduce noise.

2-8 FRONT PANEL CONNECTIONS

2-8.1 MIC The microphone circuit has been designed for low impedance microphones with a minimum 5mV output. Transistorized microphones may also be used, providing their output level is adjusted so that the input stages of the Model 535/536 are not overdriven. The cable, which should provide shielding for all leads, is terminated with a standard 4 pin microphone plug. Failure to shield both microphone and PTT leads may result in RF getting into the audio circuits. Connections to the plug are as shown in FIGURE 2-1.

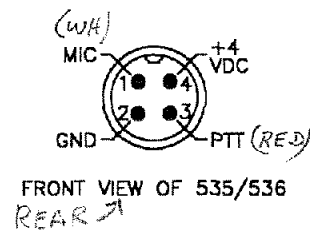

FIGURE 2-1. MIC CONNECTIONS

2-8.2 PHONES This jack is designed to be used with a standard 1/4" plug. Either stereo or monaural headphones with an impedance of 4 to 16 ohms may be used. The internal speaker is disabled when headphones are plugged in.

2-9 TOP PANEL SWITCHES

2-9.1 QSK FAST / SLOW This switch controls how quickly the receive audio recovers after a transmit condition. The fast setting gives full QSK operation for fast break-in, the SLOW setting keeps the receiver muted for approximately one second after key-up.

2-9.2 AGC FAST / SLOW, ON / OFF

These two switches set the receiver AGC action. AGC decay times of .25 or 2 seconds are selected with the FAST / SLOW switch. Fast AGC lets the receiver adapt quickly to interference and changing signal levels but SLOW AGC is generally more comfortable to use especially for routine SSB listening. With the AGC system turned OFF the receiver gain must be controlled manually using the RF gain control.

2-9.3 ATTN -20 dB / OFF This switch inserts a 20 dB attenuator pad at the receiver input. It is normally left in the OFF position. With the attenuator on, unusually large signals can be received without overload or blocking.

2-9.4 LAMP ON / OFF

The electroluminescent back light for the LCD display can be turned ON or OFF.

HEAR BOTH SIDES OF WORLD EVENTS

RX-340

USED BY GOVERNMENTS WORLDWIDE!

HF SWL receiver, 5 kHz – 30 MHz. IF stage DSP. Sync AM/selectable sideband, SAM, AM, SSB, ISB, CW, FM. Over 90 bandwidth filters, programmable AGC, built-in high stability TCVCXO. Completely remote controllable via RS-232 interface. DRM ready, no modification needed (user supplies decoding software). 90-264 VAC operation. **\$4,250**

RX-320D

LISTEN TO THE WORLD ON YOUR PC!

General coverage from 100 kHz – 30 MHz. "Black box" receiver connects to your PC via one serial port. Your PC provides the operation horsepower. A 12 kHz I-F output is included for decoding DRM transmissions with your PC sound card (user supplies decoding software). Download the actual operating software from our website for a pre-purchase test drive. **\$359**

1254

KIT BUILDING IS A WORLD OF FUN!

Build your own HF SWL receiver with our model 1254 shortwave receiver kit. 500 kHz – 30 MHz coverage in 2.5 kHz steps with clarifier control allowing tuning of all frequencies. LED digital readout. AM, SSB, CW capable. Complete step-by-step instructions and all components included. See our website for information on other available kits! **\$195**

1185 Dolly Parton Pkwy., Sevierville, TN 37862 800-833-7373 www.tentec.com

Mon-Fri 8:00-5:30 EST We accept Visa, MC, American Express, and Discover Office: (865) 453-7172 Service: (865) 428-0364



RX-340



RX-320D



1254

TENTEC

2-9.5 SQL ON / OFF

This switch controls the FM squelch feature. With the squelch on only signals strong enough to give approximately 20 dB of quieting will break the squelch. The squelch is only active in FM mode.

2-10 REAR PANEL

The following section describes the rear panel connectors. Also refer to figure 3-2 (Model 535) or figure 3-6 (Model 536).

THE FOLLOWING CONNECTIONS ARE FOUND ON THE 535/536.

2-10.1 ANT This connector mates with a PL-259 style plug. Use any 50Ω coaxial feedline to connect antennas, tuners or amplifiers to the Model 535/536. Take care that any connected load presents less than 3 : 1 SWR to the transceiver.

2-10.2 POWER 13.6 This 2 pin connector provides the main DC power connection to the transceiver. Matching plugs and terminals are included in the Model 535/536 packing kit. The DC power source must be capable of supplying a regulated voltage between 11.5 and 14.0 VDC at 3 amps for the Model 535 and 20 amps for the Model 536. See Figure 1-1 for connection information.

2-10.3 FUSE The ARGONAUT II uses an AGC 4 amp slo blow fuse and the DELTA II uses a type AGC 25 amp fast blow fuse. The fuse works in conjunction with an internal reverse polarity diode to protect the transceiver from supply voltage with reversed polarity.

2-10.4 CW KEY To key the transceiver, ground the key line using either an open collector or relay output keyer, a bug or straight key.

2-10.5 AUX DC This phono jack provides a convenient source of +13.5 VDC for accessories. Internally the jack is connected to the main DC input. This is a low current (2 Amps or less) output for small station accessories only.

2-10.6 GROUND POST Used for the primary transceiver ground. To prevent personal injury, interference and other ground related problems, connect this terminal to a good earth ground using heavy gauge copper braid or wire and make the connection as short as possible.

2-10.7 J-3 SERIAL INTERFACE PORT

This 1/8" phone jack carries serial interface data to and from the transceiver. A Model 305 Level Converter is required to interface the 535/536 to an RS232 computer port. Details on the interface protocol and the programming are contained in the Model 305 manual.

THE FOLLOWING CONNECTION IS FOUND ONLY ON THE 535 ARGONAUT II.

2-10.8 ATTENUATOR LOOP

These two phono jacks bring the 5 watt transmit output to the rear panel. Normally a plug jumper routes this transmit signal back into the radio and to the SO-239 antenna connector. To use the Model 290 calibrated attenuator remove the plug jumper and patch in the attenuator using 50Ω coax jumper cables.

THE FOLLOWING CONNECTIONS ARE FOUND ONLY ON THE 536 DELTA II.

2-10.9 SPKR An external 4Ω to 16Ω speaker can be used with the Model 536. Use a 1/4 inch single circuit phone plug for this connection.

2-10.10 FAN This output is for the Model 303 cooling fan accessory. 13.5 VDC is thermostatically switched to this jack when the heat sink temperature reaches the level of 130°-150° F.

2-10.11 J-1 ACCESSORY JACK (Model 536) This eight pin DIN jack carries many of the connections needed to implement more sophisticated station hook-ups. The transceiver is shipped with an eight pin plug installed which connects pins 5 and 8. This jumper completes the keying loop necessary for transmitter operation. Pin identification numbers are shown in figure 2-2 below. On the

following page you will find table 2-2, a description of these pin numbers in more detail. Finally, refer to figure 2-3a and figure 2-3b for information regarding amplifier hook-up.

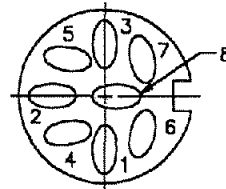

VIEW OF CONNECTOR AS SEEN
ON REAR OF DELTA II

FIGURE 2-2. ACCESSORY JACK J1

<u>PIN</u>	<u>FUNCTION</u>
1	Fixed Audio Output: Receiver audio output for modems, phone patch, etc. Output level is approximately 100 mV rms when receiver is into AGC. 1.0 K ohm output impedance, Short circuit proof.
2	PTT Line: This PTT line is paralleled with PTT pin on the front panel mic jack. Short this line to ground to key the transceiver.
3	Audio Input: Rear panel input into microphone amplifier circuit. Recommended level is between 10 mV rms and 100 mV rms. Shielded wire is a must for this connection. Connect braid to the shell of the DIN plug.
4	Receiver Mute: Ground this line to mute the receiver audio output and activate the open collector T line at pin six.
5 ²	TX ENABLE: This active low input signals the radio to begin the go-to-transmit command. Connects to key-out jack on TEC-TEC linear amplifiers.
6 ³	Open Collector T Line: Commonly used to key a linear amplifier. A phono socket on J1 is supplied connected to this pin. Open collector output provides a low current sink (≤ 250 mA) to ground when transceiver is keyed. The "hang time" of this output is internally adjustable on board No. 81531.
7 ⁴	Mic Mute Line: Ground this pin to disable the front panel microphone input during transmit.
8 ²	TX Request: This output goes low when the transceiver has been keyed from either the KEY or PTT lines. Connects to key-in jack on TEN-TEC linear amplifiers
Shell ¹	Ground Connection

TABLE 2-2 J1 ACCESSORY JACK PIN DESCRIPTIONS

NOTES :

1-The ground contact if required for your connections, is the shell of J1 or J2. A solder tab is provided on the connectors supplied.

2- Pins 5 and 8 provide a keying loop that can be routed to external accessories such as TEN-TEC tuners and amplifiers. Access to these two signal lines lets external equipment take control of the timing in the DELTA II transmitter.

3-The phono socket provided on DIN plug, J1, is supplied to make connection to a linear amplifier as easy as possible.

4- For convenient AFSK operation the MIC MUTE and PTT lines can be wired together. When this combined connection is grounded, the radio is keyed and the AFSK tones can be injected through the audio input at pin 3 without interference from the front panel microphone.

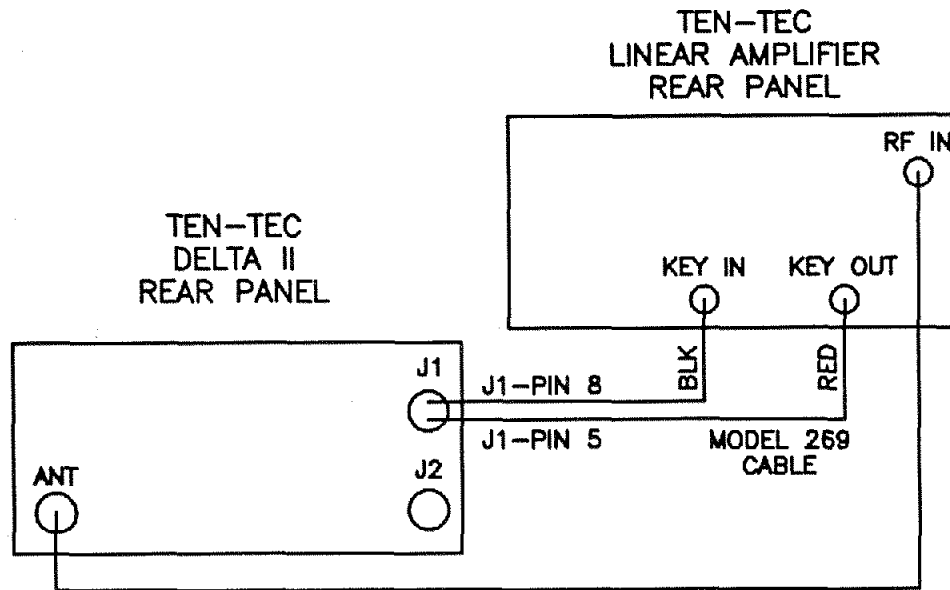

FIGURE 2-3a CONNECTION OF DELTA II TO TEN-TEC AMPLIFIER

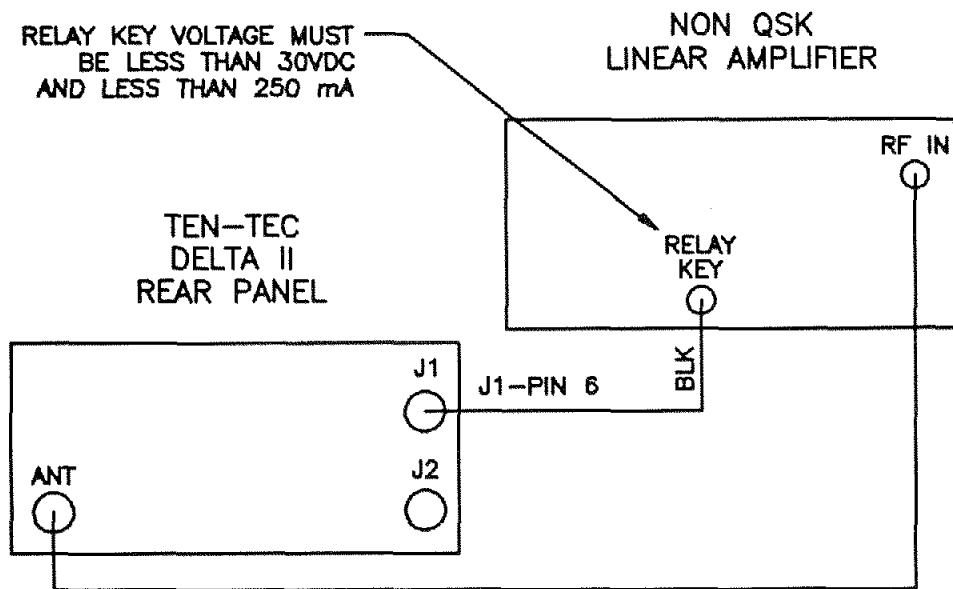
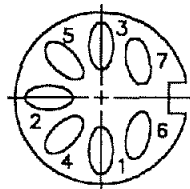

FIGURE 2-3b CONNECTION OF DELTA II TO NON QSK AMPLIFIER

2-10.12 J-2 BAND LINE OUTPUTS

FIG. 2-4 These active high outputs indicate on which one of six band segments the transceiver is tuned. These lines are provided for selecting bands on TEN-TEC amplifiers and tuners or for switching antennas. The output voltage is typically 2 volts below the supply voltage fed to the DELTA II. Take care not to draw more than 5 mA from these outputs, they are not short circuit proof.



VIEW OF CONNECTOR AS SEEN
ON REAR OF DELTA II

FIGURE 2-4 ACCESSORY JACK J2

<u>PIN</u>	<u>BAND</u>
1	21.5-30.0MHz
2	14.5-21.5MHz
3	noconnection
4	7.5-14.5MHz
5	4.0-7.5MHz
6	2.5-4.0MHz
7	0.1-2.5MHz
Shell	Ground

Remote control hook-up for band selections between Model 536 and Model 420/253. Refer to figure 2-5a and 2-5b.

<u>PIN</u>	<u>MODEL 536</u>	<u>PIN</u>	<u>MODEL 420/253</u>
7	(.1 - 2.5) TO	1	(1.7 - 2.5)
6	(2.5 - 4.0) TO	4	(2.5 - 4.0)
5	(4.0 - 7.5) TO	10	(6.5 - 10.5)
4	(7.5 - 14.5) TO	13	(10.5 - 15.0)
2	(14.5 - 21.5) TO	2	(15.0 - 22.0)
1	(21.5 - 30.0) TO	5	(22.0 - 30.0)

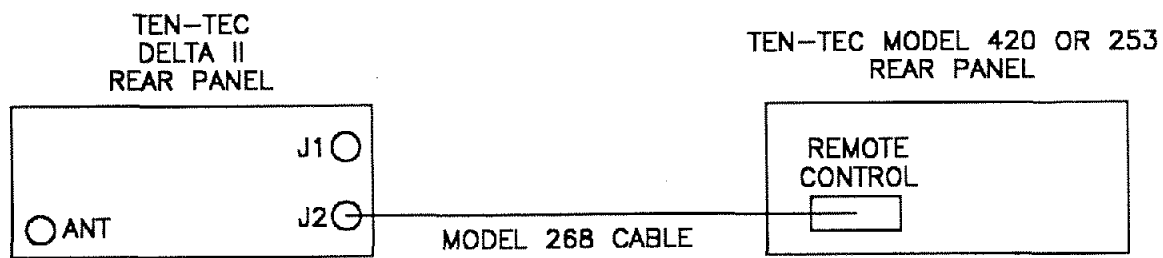

FIGURE 2-5a CONNECTION FOR REMOTE BANDSWITCH CONTROL OF 420 OR 253 BY DELTA II

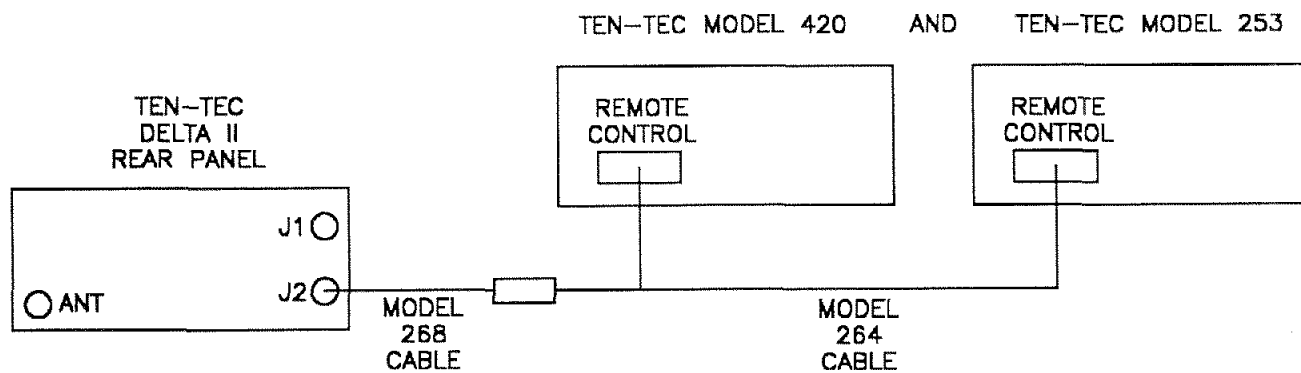

FIGURE 2-5b CONNECTION FOR REMOTE BANDSWITCH CONTROL OF 420 AND 253 BY DELTA II



CHAPTER 3

OPERATING HINTS

3-1 INTRODUCTION This section provides additional useful information for getting maximum performance out of your Model 535/536. Also included is TABLE 3-1, which provides trouble-shooting information in the event you experience problems.

3-1.1 CW In the CW mode, the indicated frequency is the transmitted frequency. To accurately read an incoming signal, therefore, it is necessary to tune to a 700 Hz beat note.

When the 535/536 is switched to CW mode, the output of the product detector is passed through a 1 KHz low pass filter. This reduces background hiss, atmospheric noises, and makes CW operation less fatiguing. Other signals outside the audio filter may be present, but not heard, and will activate the AGC, causing a "pumping" action. It is recommended that the IF-BW bandwidth control be set to approximately 12 o'clock. This will set the IF filter to 1 KHz bandwidth and eliminate the possibility of receiving a signal outside the audio filter passband.

3-1.2 FM The 535/536 will operate transceive ± 5 kHz deviation FM. The PBT, IF-BW, and Noise Blanker switches do not function in this mode. The FM squelch is active when selected on the top panel. The AGC switch must be on to enable the S-meter. If split RX / TX is desired when operating through repeaters, program the transmit and receive frequencies in VFO A and VFO B. The MIC control has no effect in the FM mode

and deviation (normally preset for the Model 705 microphone) is adjusted internally and preset at the factory. The power output is adjustable with PWR control as with other models.

3-1.3 PROTECTIVE CIRCUITRY & ALC ALC serves three major functions:

1) assures maximum power from the transmitter without critical adjustment of the input drive.

2) prevents the amplifier from being overdriven into the nonlinear, distortion-producing area.

3) serves as a power limiting device which protects the output transistors.

3-1.4 SOLID-STATE POWER AMPLIFIERS Although transistors and vacuum tubes both can be made to amplify RF power, there are some fundamental differences in how this is accomplished. A better understanding will aid in recognizing correct or incorrect performance.

Misconceptions sometimes arise from incomplete knowledge. This results in erroneous conclusions being drawn that the equipment is faulty, erratic, or not performing to specifications. The purpose of the following information is to brief you on solid-state "no-tune" RF amplifiers so you can knowledgeable approach and correct any apparent improper performance characteristic.

3-1.5 BROADBAND vs RESONANT TANKS Almost all tube circuits use resonant tanks in the plate circuit. The 535/536 uses a broadband system. In class AB operation, these two approaches act similarly without drive being applied. The idle current is relatively low and within the device dissipation rating, even with load impedance variations from open to short circuit.

However, with drive applied, the two act very differently. In the case of tubes, the dissipation within the tube depends on both the tuning of the tank and the load applied. If the tank is resonated and the load is very light, the internal power dissipated is quite small as indicated by the null which reduces plate current almost to the level with no drive. Out of resonance, the plate current, and hence dissipation, increases rapidly and may damage the tube from overheating. In resonance, as the load is increased, the null becomes more shallow at a higher plate current as a result of the power being delivered to the load. As the tank is tuned to resonance, the load impedance, which is usually on the order of 50Ω , is transformed to a relatively high impedance of several thousand ohms to match the plate circuit impedance. Small load reactive components, either capacitive or inductive, can usually be balanced out in the tank resonating function.

With transistors, drive applied and no load, there is no resonant high impedance to limit the collector current, and so power is poured into the circuit (much as the out-of-resonance tank condition). Since there is no load power, all has to be dissipated in the transistor. So even with no load, the ALC LED may light as the current limiting circuitry is automatically reducing drive level, or the power supply circuit breaker may trip. The broad-band transformer system used with transistors transforms the 50Ω load impedance not higher, but much lower (on the order of 4 or 5 Ω) to match the transistor output impedance. Since this transformation is fixed in design, any reactive component in the load impedance is

applied in a transformed way to the collector circuit. Certain reactances at this point, especially inductive, give rise to parasitic oscillation. To correct for this, the antenna impedance should be changed to remove this reactance, or a matching network should be inserted between the antenna and transceiver. It is important to remember that any antenna changes its impedance with frequency, so one that resonates well at one end of the band may well cause oscillations to activate the current limiting or trip the circuit breaker on the other end of the band. If entire band operation is desired, especially on the lower bands, an adjustable matching network would be the better choice, rather than try to make the antenna behave over the entire band on a cut-and-try basis.

A final point to bring out regarding broadband vs tank systems is that there is a limit to the amount of current that you can draw from an emitting filament, and this saturation current will limit the amount of power drawn from the supply. In the case of transistors, where the collector internal impedance is only a fraction of an ohm, extremely high currents can be demanded of the power supply, especially with mismatched loads well below 50Ω . A fuse is provided in the 535/536 for protection when operating from a power source that is not limited.

3-1.6 SWR - Two Kinds The standing wave ratio is a direct measure of the ratio between two impedances, i.e. a SWR of 3 to 1 indicates that one impedance is three times the other. Therefore, the unknown impedance can be either three times as large or three times as small as the known one. If the desired impedance that the transceiver wants to see is 50Ω , an SWR of 3 to 1 on the line may mean a load impedance of either 150Ω or one of 17Ω . If it is 150Ω , the transmitter will act differently than if it is 17Ω . In the first case, the power demanded from the power supply will

be much lower, and not large enough to trip the circuit breaker. In the second case, even though the SWR reads the same, the breaker may repeatedly trip out. The SWR reading gives no indication of reactive components, nor can it separate the resistive from the reactive components. It is calibrated with a pure resistive load and therefore has its greatest accuracy with pure resistive loads. The SWR bridge should be used only as an indicator when attempting to adjust antenna systems to a pure 50Ω resistive impedance at the transmitter output point.

3-1.7 EFFICIENCY Since transistor amplifiers have a very low value of output impedance, they act more or less as a constant voltage source. That is, the RF output voltage tends to remain at a fixed value regardless of the load impedance. Hence, the output power will vary depending on the value of the load, and increases as the load impedance goes down. It can be seen that a 3 to 1 SWR on the low side of 50Ω will ask the amplifier to deliver much more power than a 3 to 1 SWR on the high side. Since the amplifier does have a finite value of output impedance, the amount of power delivered to the load with efficiency will change with load. Unless the load is near the design value, the transistors will heat up unnecessarily without delivering any more power to the antenna.

Recommended Reading: ARRL HAND-BOOK

IF YOU HAVE TROUBLE

If the transceiver should fail to operate normally, use the following chart as an aid in determining the problem. Often the cause of the problem is an overlooked switch/control or a mistake in entering information into the keypad.

SYMPTOM	POSSIBLE CAUSE
Transceiver dead, no meter illumination, no display.	Check power switch on transceiver and power supply. Check power cable. Check supply for correct voltage.
Receiver dead, meter and display on.	Check AF, and RF gain controls. Check Phones and Ext. Spkr jacks. Check squelch if FM mode selected.
Transmitter dead, meter and display on.	Check TX EN/TX REQUEST jumper plug on rear panel. Check microphone, PTT switch, and microphone cable & connector.
Received signal strength low.	Check ATTN switch and RF gain control.
Main tuning knob will not change frequency.	Check that the MT annunciator is turned off. If "LOCK" appears in readout, press F , M. TUNE
Main tuning knob will not change frequency, keypad will not respond to input. No readout, audio present. Readout present, can not enter commands.	Microprocessor may be in process of a selected function routine. Memory Tune mode is selected with no memory locations. Microprocessor may be locked up due to an incorrect keyboard entry or a power supply noise spike. Turn the POWER switch on the 535/536 off and then back on. If this does not clear the problem, the microprocessor will have to be reset. With power on, press the RESET button with a toothpick or similar non-metallic object. The button is located underneath the top panel in between the LAMP and SQUELCH on/off switches. NOTE: PRESSING THE RESET SWITCH WILL RESET THE TIME. Use this approach only as a last resort.
Clock contains erroneous readings after power has been removed from 535/536.	Replace 3 VDC Lithium backup battery. See section 1-8.
Display Blinking	Indicates that the supply voltage is less than 10.8VDC.

TABLE 3-1. TROUBLE SHOOTING CHART

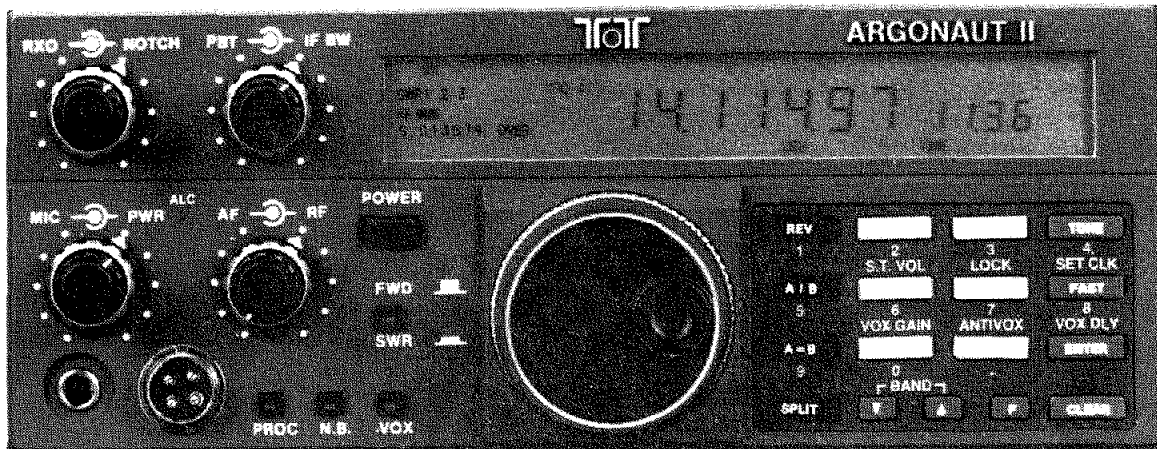

FIGURE 3-1. MODEL 535 FRONT VIEW

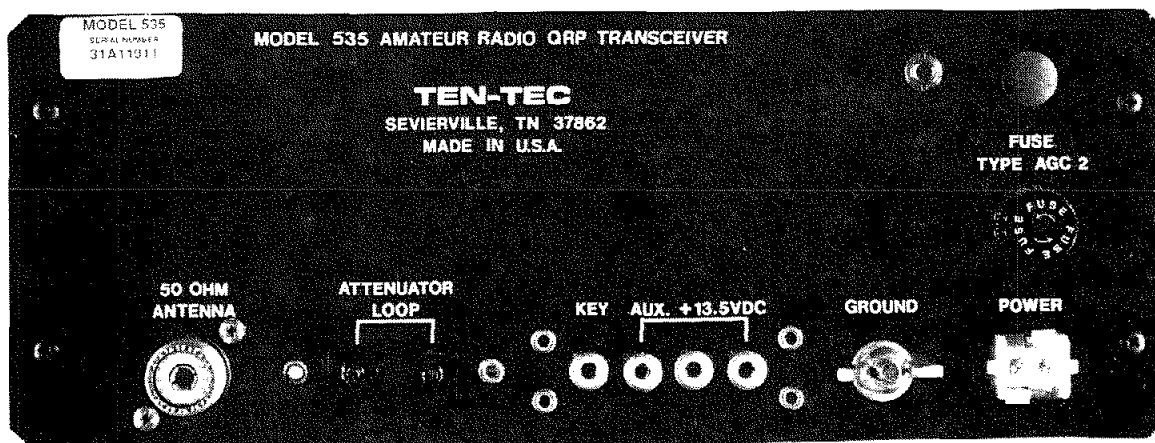

FIGURE 3-2. MODEL 535 REAR VIEW

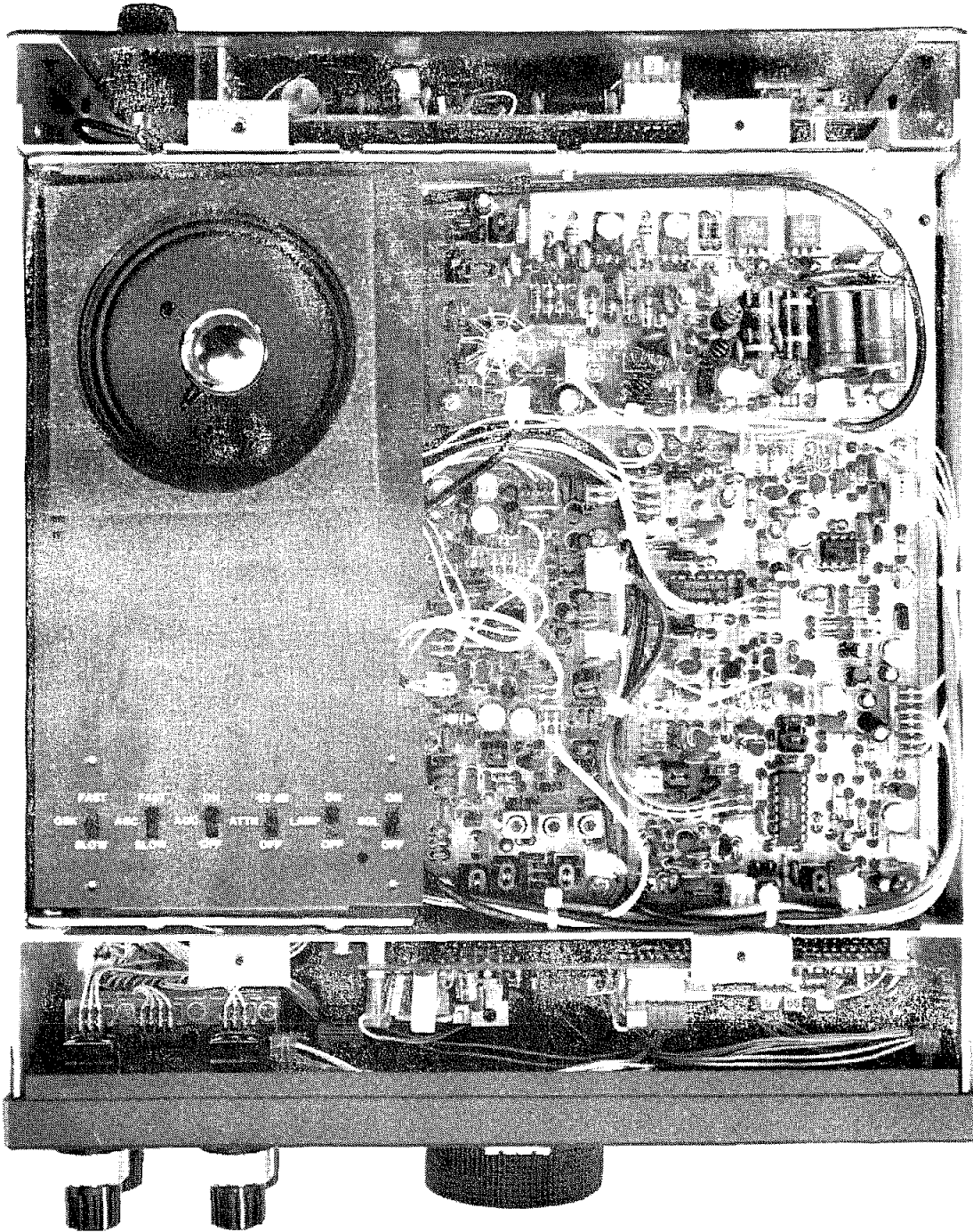

FIGURE 3-3. MODEL 535 TOP VIEW

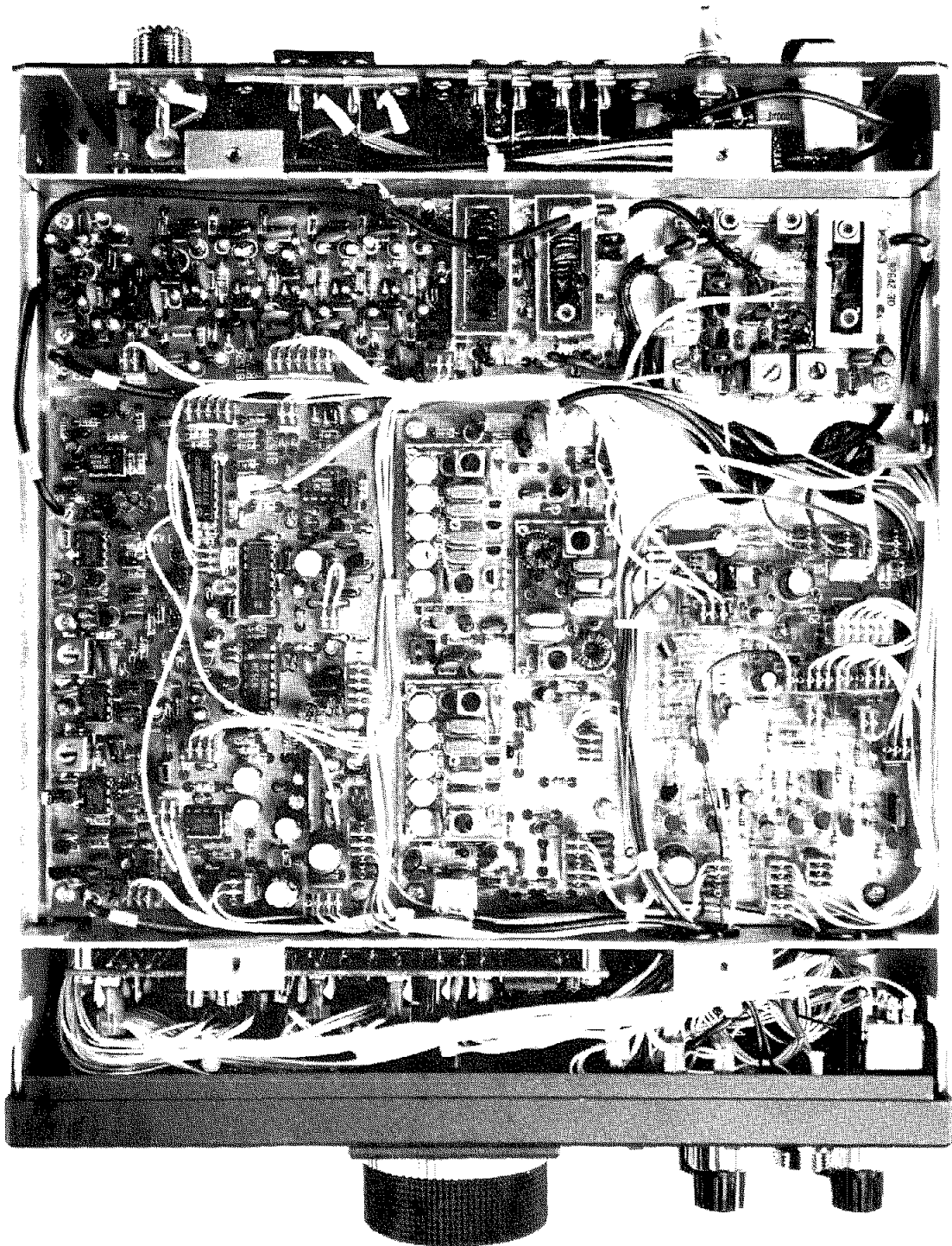

FIGURE 3-4. MODEL 535 BOTTOM VIEW



FIGURE 3-5. MODEL 536 FRONT VIEW

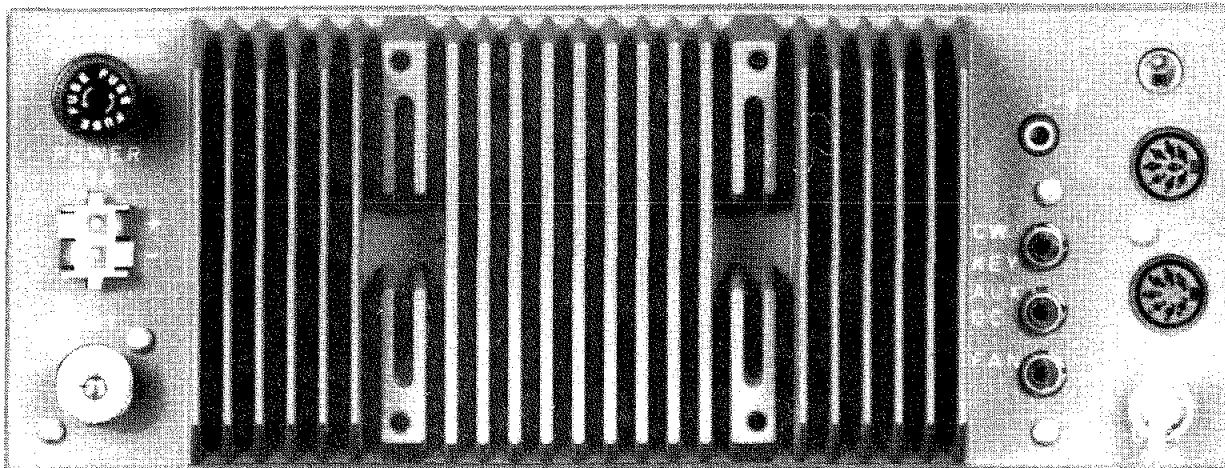

FIGURE 3-6. MODEL 536 REAR VIEW

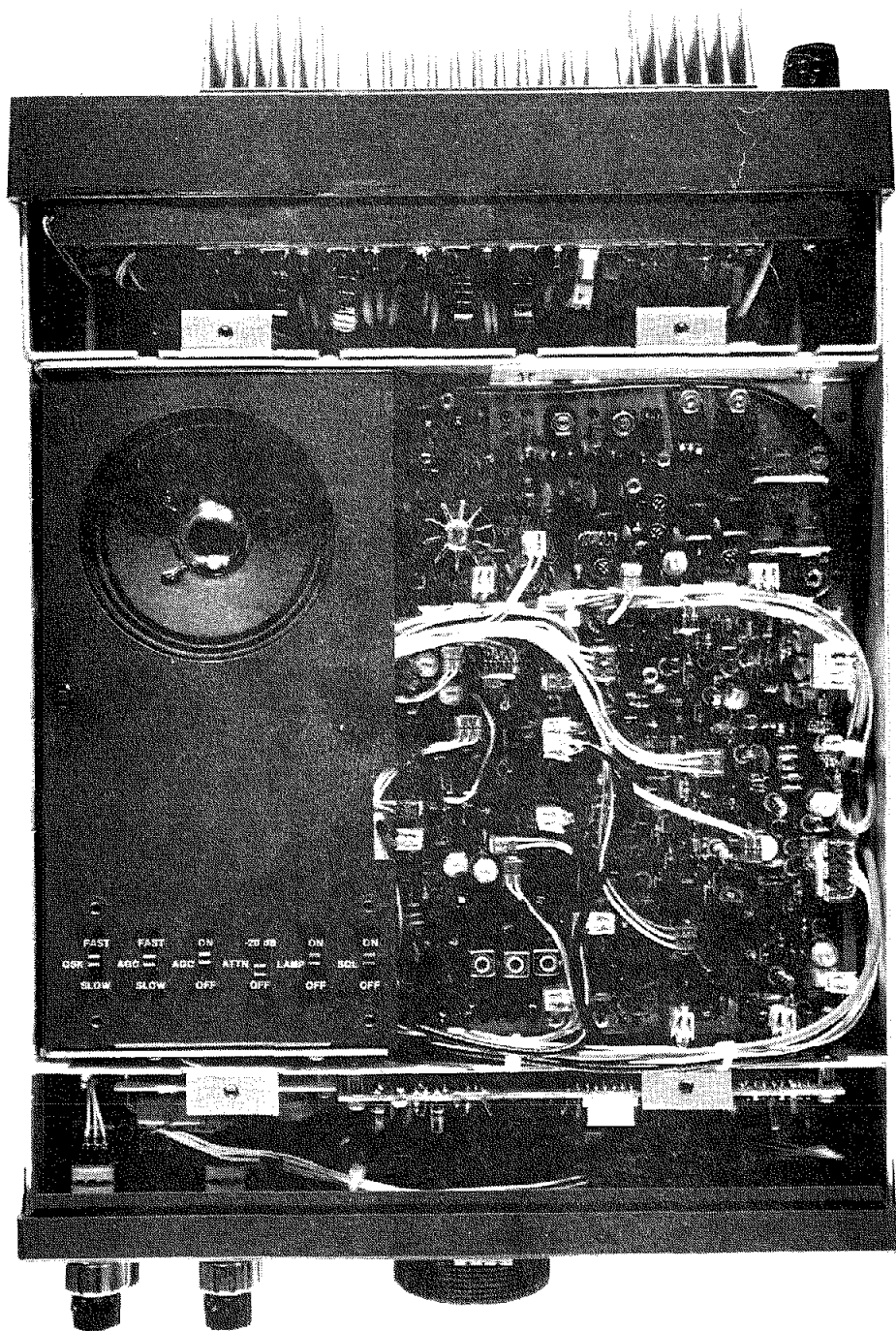

FIGURE 3-7. MODEL 536 TOP VIEW

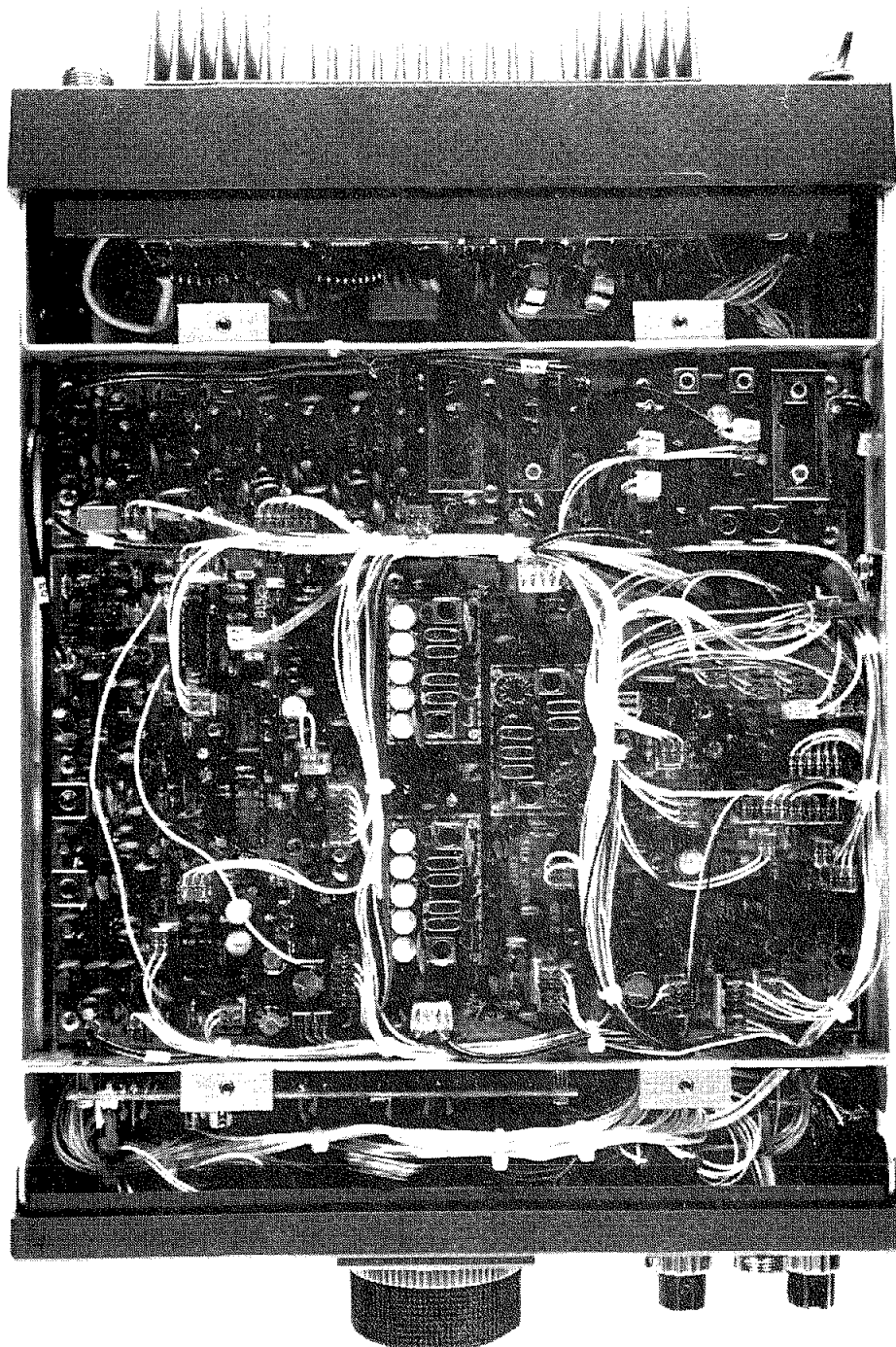

FIGURE 3-8. MODEL 536 BOTTOM VIEW

“Great sounding rig! Must be a Ten-Tec.”

All the Ten-Tec rigs that I've owned have excelled in audio. I owned a pair of (other brand) transceivers but Ten-Tec beats them in transmit audio - K4NTY

Great audio! Full, rich, natural! - K4TEN

Good audio quality and it sounds like my natural voice - K6WLM



Excellent audio. I was working a station in Puerto Rico and he stopped the calling stations and asked me what I was running. I told him the Jupiter and he said “I should have known it was a Ten-Tec.” - WD4PG

I'm confident that I will have the best signal I can possibly produce! - W1RGO



I am amazed how clean and clear I sound - W4WUQ



Very well balanced audio; natural sounding, pleasing to listen to. One of the best sounding rigs on the band. Well rounded with clarity. - KA4ICK

I get great unsolicited audio reports with the Ten-Tec Orion - WA8VSJ

Hearing is everything.

What separates one rig from another? The way they sound on the air. When you hear quality SSB transmit audio, you know it's Ten-Tec. No one matches our combination of great audio, ease of use, and receiver performance. Visit our webpage at radio.tentec.com/videos/howto and see an audio and video demo on Ten-Tec transceiver transmit audio! For complete information on our HF transceiver line, visit our website or call (800) 833-7373.

Proudly made in Sevierville, Tennessee USA

www.tentec.com

1185 Dolly Parton Pkwy., Sevierville, TN 37862. Sales: 800-833-7373 M-F 8:00-5:30 (Eastern Time) sales@tentec.com. Office: (865) 453-7172. FAX: (865) 428-4483. Service: (865) 428-0364 M-F 8:00-5:00 (Eastern Time), service@tentec.com. We accept Visa, MC, American Express and Discover.

CHAPTER 4

CIRCUIT DESCRIPTIONS AND ILLUSTRATIONS

4-1 INTRODUCTION The Model 535/536 are completely synthesized transceivers. The receive portion covers 100 KHz to 29.9999 MHz while the transmitter covers the amateur frequencies. A simple modification will allow transmission outside the amateur frequencies for MARS operation etc.

RECEIVER

The transceiver T/R switching on the low pass filter (81521) routes the received signal to the band pass filter, amplifier and mixer (81526). The first conversion oscillator (81528) converts 10 KHz portions of the received spectrum to the first IF of 45 MHz. The second mixer board (81524) filters the 45 MHz, to improve the image response, and with the second conversion oscillator converts the 45 MHz to the final IF of 6.144 MHz. The second conversion oscillator (81529) covers the 10 KHz at 45 MHz in steps of 10 Hz. The major selectivity for the receiver is provided in the filter board (81527) where either the AM filter or the variable SSB/CW filter may be selected. The variable filter may be set to any bandwidth between approximately 500 Hz and 2.5 KHz with the front panel control. The IF amplifier (81525) provides AGC, AM detection, SSB/CW detection, audio processing and the CW sidetone.

PLL

All oscillators, first conversion, second conversion and BFO are phase locked to the master

reference of 9.9 MHz. Therefore, the stability of the transceiver depends solely on the stability of the 9.9 MHz crystal oscillator. The first conversion oscillator is stepped at 10 KHz, the second conversion oscillator at 10 Hz and the BFO at 20 Hz. The pass band tuning function is accomplished by changing the second conversion oscillator and the BFO by the same amount. This has the effect of moving the filter pass band without changing the frequency of the received signal. The frequency of the carrier for USB and LSB is generated in the PLL BFO and is determined by the microprocessor.

TRANSMITTER

The BFO (81530) provides the carrier for the balanced modulator, and the frequency modulated oscillator for the FM mode. Selection between the two oscillators is on the TX Mixer (81507). The SSB/CW signal, microphone audio for both the SSB/CW and FM modes and vox circuits are accomplished on the TX Audio board (81506). The TX Mixer board combines the signals from the TX Audio, second conversion, and first conversion oscillators to produce the wanted frequency. The required frequency is amplified to the output level in (81502). Low pass filter (81508) removes the harmonics and provides the T/R switching.

4-2 KEYPAD BOARD (81499)

This board contains a seventeen key matrix organized in a four by four array, with the one extra key (S15) tied to the matrix through diodes D1 and D2. Column address information from the microprocessor U6 on the Logic Board is routed via connector K to U1, a one of eight BCD decoder chip. When addressed by the microprocessor, only one column output from U1 will be set high at a time. Unselected columns will remain low. All columns are thus scanned one at a time by the microprocessor. When a key is pressed, that keys column line is tied to its row line, thus placing a high on that row line when its corresponding column is strobed by U1. The status of all row lines is returned via connector J to the microprocessor. Each key thus has a unique column/row value which is looked up in a table by the microprocessor to determine which key was pressed.

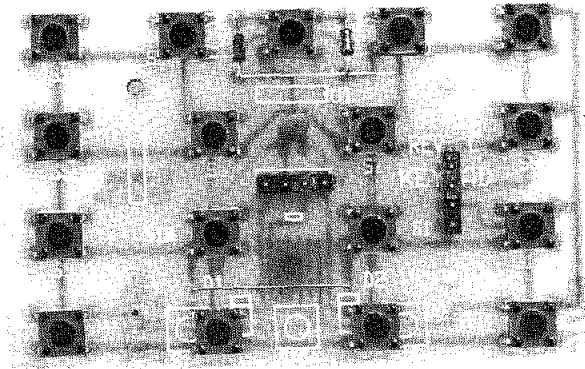

FIGURE 4-1. KEYPAD BOARD COMPONENT LAYOUT (81499)

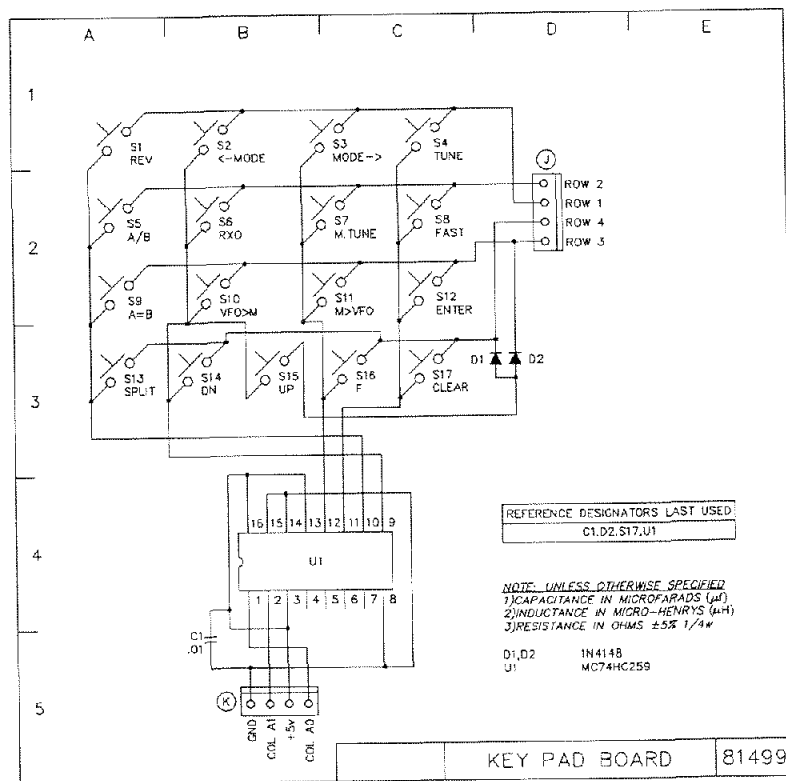

FIGURE 4-2. KEYPAD BOARD SCHEMATIC (81499)

4-3 LOGIC BOARD (81500)

This board contains the microprocessor control system, a 32 line driver, an A-to-D converter, a non-volatile RAM chip, a real time clock chip, rotary encoder circuitry, and a DC-to-AC inverter for the display backlighting system.

The microprocessor, U6, is the heart of the system. This is an 8-bit CMOS microprocessor with 25 I/O lines, an 8 K ROM, 176 bytes of CMOS RAM, a serial peripheral interface (SPI), a serial communications interface (SCI), and a built-in 16 bit timer. This microprocessor contains an internal oscillator whose frequency is controlled by X1. The I/O lines going to connector B are used to control the two loop PLL synthesizer. Signals from connector 95 control the PLL synthesized BFO frequency. On connector 62, U6 monitors the TX RQ line to tell when it should go into transmit mode. When TX RQ goes high, U6 will change the frequency synthesizers as needed and insert any needed timing corrections before enabling the transmitter output by setting TX ACK high.

Pin 23 of U6 is used to monitor the +10 volt regulated line in order to detect when the POWER switch has been turned off or the DC power supply has been removed. When this happens, U7 is placed into a "sleep" mode to conserve power but still retain its memory. While in the "sleep" mode, power for the real time clock chip, U9, and the CMOS RAM in the microprocessor, is obtained from B1, a 3 volt lithium battery. In normal usage this battery has a typical life of 1 to 3 years.

When power is again turned on, with U6 asleep, transistors Q1 and Q2 generate a negative going pulse on the interrupt line (pin 2) of U6. This wakes the microprocessor up and restores it to normal operation. The interrupt line is also used by the encoder circuit to tell the microprocessor when to change the transceivers frequency. The clock pulse from the encoder circuit is coupled via C12 to the

interrupt (pin 2) of U6. Pin 24 of U6 is used to tell whether the encoder is tuning up (high) or down (low).

The I/O lines going to connector K are used to drive a decoder chip located on the Keypad Board. When scanning the Keypad, the data on connector K (A0, A1) will be decoded by the decoder and cause one of the column lines in the matrix to be set high. By changing the value of A0, A1 all four columns are strobed in sequence. While strobing each column, U6 looks at the row information provided from the Keypad matrix via connector J. When it detects a key closure, U6 decodes the location in an internal lookup table and executes the appropriate command.

Connector G provides signals from U6 to control the driver chip on the LCD Display Board. Power for the LCD Display is obtained from connector H. Transistors Q3 and Q4 form a DC-to-AC inverter circuit to power the electro-luminescent display backlight. The regulated +10 volts input to the inverter is controlled by a switch located on the top cover mounted switch panel. The output of the inverter is an approximate sine wave of about 115 VAC (r.m.s.) at a frequency of about 250 Hz. This output is sent to the display board via connector I. (CAUTION: Although this high output voltage is not lethal, it can cause a shock if you touch the connector or bare leads with exposed skin).

U1 is a 32 bit, serial input, latched driver controlled by U6 over the SPI interface system. Output pins 3-6 drive a four bit resistive D-to-A converter used to generate a VOX DELAY control voltage under microprocessor control. This is one of the Soft Key functions controlled by U6. In like manner output pins 7-10 drives a resistive D-to-A circuit to develop the ANTIVOX control voltage. Output pins 11-14 similarly develop the VOX GAIN control voltage. All three voltages are sent to the Vox circuits via connector 41. Output pins 15-18 are used similarly to develop the SideTone

level control voltage, which is routed to connector 91.

Output pins 23-29 contain band information used to drive the bandpass(connector 79) and lowpass(connector 10) filter selection circuits. In addition, these signals are also used to control the VCOs used in the main PLL via connector A. The lowpass filter lines at connector 10 are also inverted by U10 and applied to connector 3 for use with the Model 536 DELTA II low pass filter board.

Output pin 30 is used to turn the BFO circuit on or off via connector 96. Pin 31 is used to activate the TUNE mode on the control board via connector 62. Pins 32 and 33 select the appropriate filter for either SSB or AM operation. Output pins 34-37 select the appropriate mode lines via connectors 91 and 62. Pin 38 is used to generate a Spot Tone function when the REV key is pressed during CW operation.

The main tuning control consists of an optical rotary encoder located on the front panel. This encoder generates quadrature signals (each signal being 90 degrees out of phase). The rotary encoder produces 120 pulses per revolution of the Main Tuning Knob. The two quadrature signals are sent via connector N to U4. These gates detect the leading and trailing edges of the signals and generate an output pulse for edge, thus multiplying the number of pulses by four. The pulses applied to U2 are used to detect the direction of the encoder. The UP/DOWN output of U2(pin1) goes to U6(pin24). The encoder pulses are also sent to U5 which buffers the signal and then integrates it to develop a tuning rate detector. When the repetition rate of the pulses exceeds a predetermined threshold, the output of U5D goes high, telling the microprocessor to shift to the next higher tuning step size.

The real time clock circuit consists of U9, X2, and trimmer capacitor C7. Backup power is supplied from a replaceable 3 volt

lithium battery, B1. To calibrate the clock a frequency counter may be connected to TP1 and trimmer C7 adjusted until the counter reads 128 Hz. If the counter has period measurement capability, an even more accurate setting may be obtained by placing the counter in period mode and adjusting C7 for a period of 7.8125 mS. U9 is serially controlled by U6 pins 21-22. These two serial control lines also connect to and control U7, a 512 byte NVRAM, which is used to store memory information. Connector 99 provides blanking pulses to the IF/AF and PLL synthesizer boards. These pulses, generated by microprocessor U6, help reduce audio transients generated by the PLL synthesizer system when a loop boundary is crossed or the frequency is suddenly changed by a very large amount.

The serial communications interface (SCI) signals are connected via connector O to a Remote Control Board mounted on the rear panel. This allows for control of the transceiver via a two-wire serial interface system. The baud rate is fixed at 1200, and the transceiver address is user selectable.

U3 is an eleven channel, 8-bit, A-to-D converter. It is controlled via the SPI interface by microprocessor U6. Only seven of the analog inputs are used, all others are tied to ground. The reference voltage for U3 is +5 volts applied to pin 14. Analog input number 1 (pin 1) is tied to the +13.5 volt supply line. Whenever this line falls below about 10.5 volts, the microprocessor U6 causes the entire LCD Display to blink, indicating a low voltage condition. Analog input 2 (pin 2) is connected to the front panel mounted FWD/REV switch and is used like an extra input pin for the microprocessor to sense the switch setting. Analog input 3 (pin 3) is the S-Meter signal developed on the IF/AF Board. The relative value of this voltage is displayed on the LCD Bar graph when in receive mode. Analog input 4 is the FWD power signal from the SWR bridge and is used to indicate relative forward

output power on the bar graph display. In like manner, input 5 is connected to the REV power signal via connector 28. Analog inputs 6 and 7 are routed via connector F to the PBT and RXO potentiometer circuits, respectively. Voltages developed by the circuits are analyzed by microprocessor U6 and used to adjust the synthesizer circuits to the correct frequencies for

all control settings and modes of operation. Regulated +5.6 volts is supplied by U8 through isolation diodes D2 and D9.

The Logic Board also contains the 3VDC lithium battery that supplies power to the built-in 24 hour clock. See paragraph 1-8 for battery replacement.

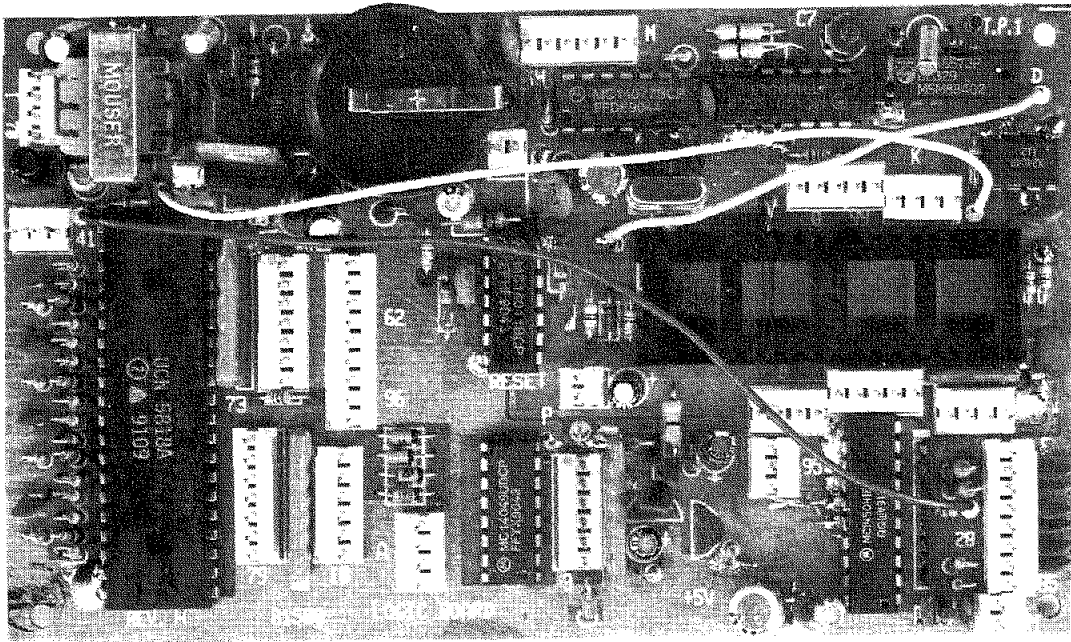
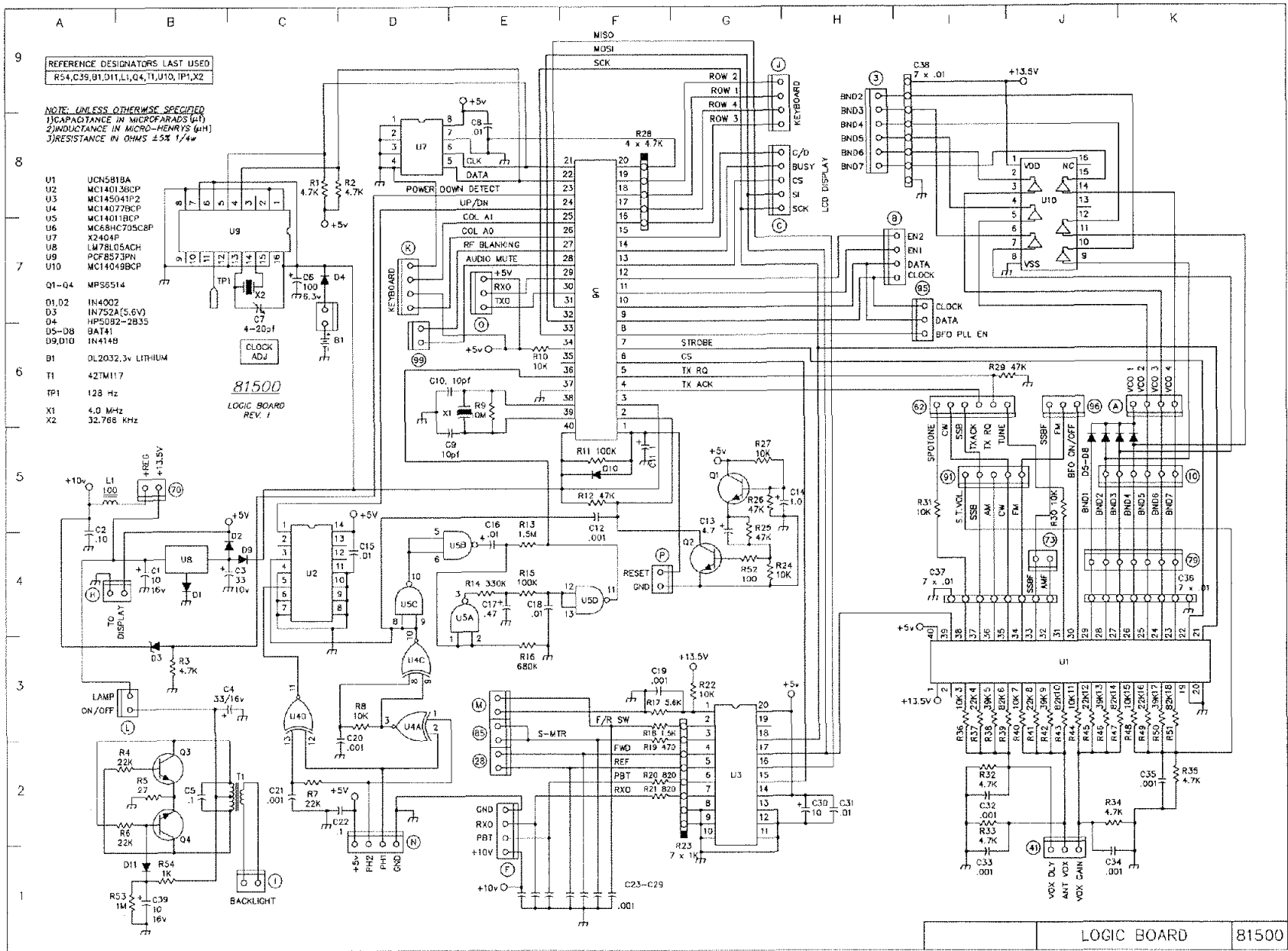

FIGURE 4-3. LOGIC BOARD COMPONENT LAYOUT (81500)

FIGURE 44. LOGIC BOARD SCHEMATIC (81500)



4-4 LCD DISPLAY BOARD (81501)

This board contains a custom designed transfective TN type LCD Display and a surface mount LCD driver U1. The display is multiplexed at about a 100 Hz rate by driver U1. There are four backplanes on this display. Information to control the driver is provided serially via connector G from the microprocessor located on the Logic Board. The multiplex frequency of the driver is determined by R2

and is set to produce an optimal rate of about 100 Hz. Resistor R3 and capacitor C1 provide a power up reset pulse to the driver, which is powered from +5 volts via connector H. The remaining resistors and capacitors comprise a voltage divider network to develop the correct backplane levels for the driver. The display backlight is powered from the Logic Board via connector I.

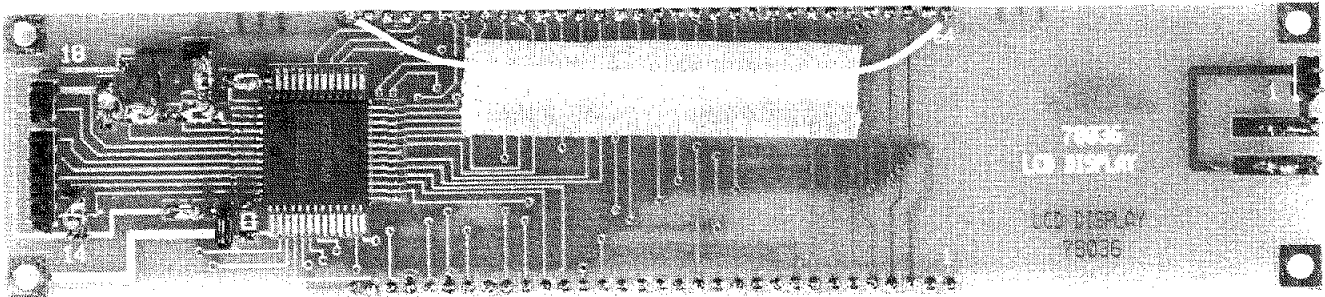

FIGURE 4-5. LCD DISPLAY BOARD COMPONENT LAYOUT (81501)

4-5 ARGONAUT II 5 WATT POWER AMPLIFIER BOARD (81502) (DELTA II Low Level Driver For 100 Watt Amplifier Board 81503)

This RF module has three stages of amplification, bias compensation and frequency leveling networks to produce five watts and uniform gain over the frequency range of 1.6 MHz to 30 MHz.

AMPLIFIER

Q1 is a broadband class A amplifier with the input impedance, gain and frequency response set by the feedback elements C2, L1, R5, R3, R4, and C6. Q2 and Q3 form a broadband class AB linear driver stage with input and output impedance matching accomplished by broadband transformers T2 and T3. RC networks R7, C11, and R10, C13 in conjunction with feedback networks C12, R25, and C14, R13 control the input impedance and flatten the gain variation of the transistors over the fre-

quency range. Q5 and Q6 are used in a five watt output class AB stage. Input impedance and gain variation with frequency are controlled by RC input networks and RF feedback similar to the driver stage. Broadband transformer T5 matches the output stage to 50 ohms for driving the transmit low pass filters.

BIAS

Bias for both stages is temperature compensated, to maintain a relatively constant operating point, by mounting the bias reference diodes D1, D2, and D3 in thermal contact to the heat sink. The temperature dependent voltage across each reference diode is added to a portion of the bias voltage and sum is used as the bias voltage.

Alignment: The final amplifier bias voltage is set by connecting a current meter to the "BIAS TP" connector and adjusting R17 for a reading of 50 mA. After adjustment, remove the meter and insert the jumper.

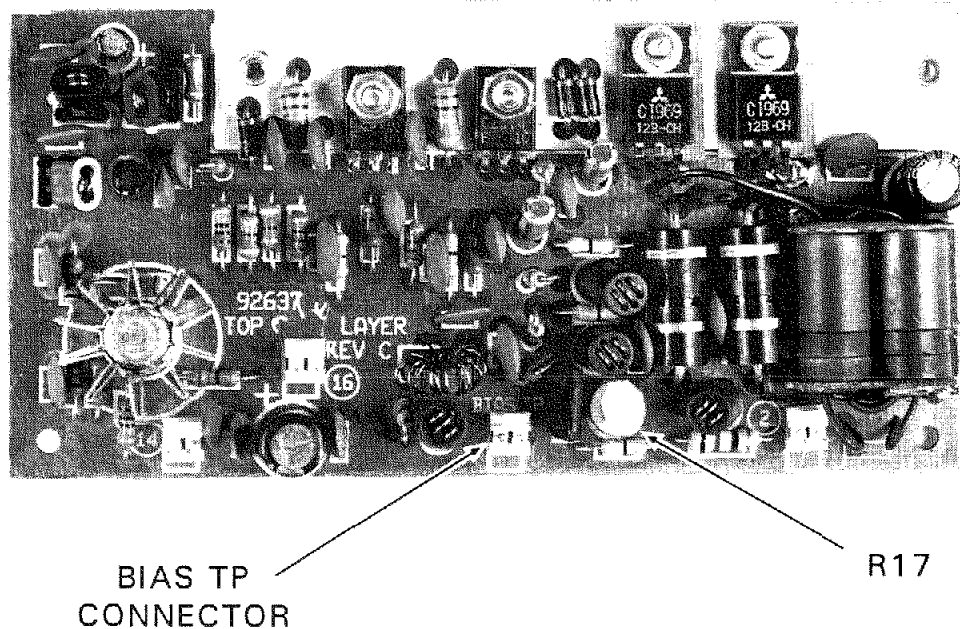

FIGURE 4-7.
5 WATT POWER AMPLIFIER BOARD COMPONENT LAYOUT (81502)

More than just a radio.



Ten-Tec is more than just a manufacturer of Amateur Radio equipment. Our legendary service department repairs almost everything we've ever built. Customer support representatives are active hams that can provide the advice you need to obtain the right equipment and set up your station the way it should be. No one in the industry matches our risk-free trial period for new equipment. When you buy Ten-Tec, you get our entire company in the box with your new radio. Ask a friend who owns "us". Proudly MADE IN USA!

1185 Dolly Parton Pkwy., Sevierville, TN 37862 Sales: 800-833-7373

We accept Visa, MC, American Express and Discover. Office (865) 453-7172. FAX (865) 428-4483.
Sales: Mon-Fri 8:00-5:30 (Eastern Time), sales@tentec.com. Service: Mon-Fri 8:00-5:00 (Eastern Time),
service@tentec.com, (865) 428-0364. Shipping is additional. TN residents add 9.5% sales tax

www.tentec.com

FIGURE 4-8. 5 WATT POWER AMPLIFIER BOARD SCHEMATIC (81502)

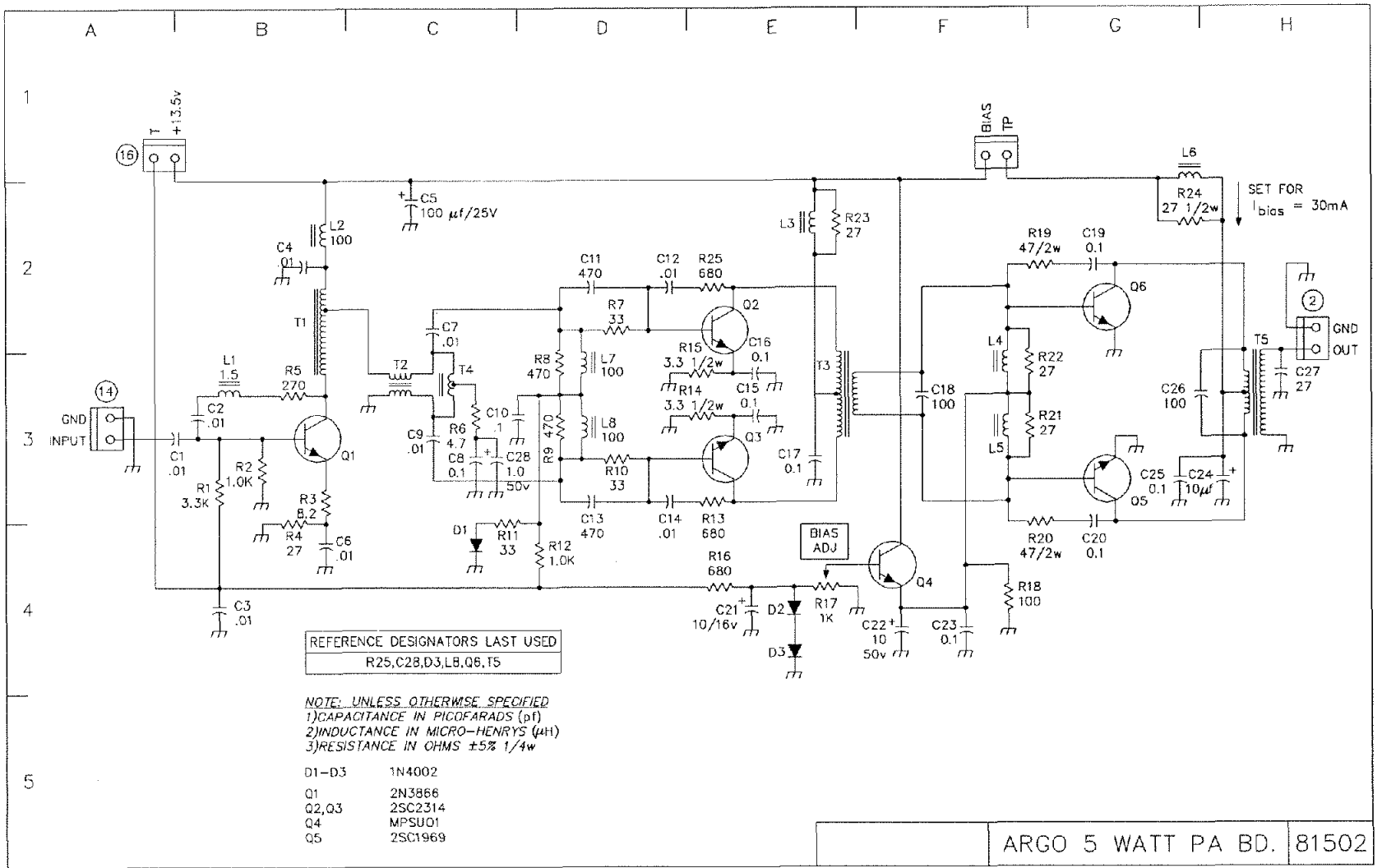

4-6 DELTA II 100 WATT AMPLIFIER BOARD (81503)

The 100 watt amplifier board bolts to the inside of the rear panel die casting. Besides the amplifier stage this board contains the main power-on relay, K1, which is activated by the front panel power switch.

RF power transistors Q1 and Q2 provide about 13dB of gain to boost the 5 watt output from the driver stage up to 100 watts out. Transformers T1 and T2 perform impedance matching and other components provide feedback to help flatten the frequency response of the amplifier.

The base bias voltage is developed from transistor Q4. This transistor is bolted to the heatsink so that the base-collector junction voltage drop follows the temperature of the RF

transistors. U1A and Q3 form a current amplifier stage which provides a low impedance source of base bias.

Comparator U1B monitors the junction voltage at Q4 and switches on the cooling fan output at a preset heat sink temperature determined by R19.

Alignment: The 100 Watt amplifier bias voltage is set by R19. Place current meter in series with the DC power supply lead. Set R19 to minimum position (full CCW). Unplug cable 2 from the 5 Watt Power Amplifier Board (81502). Set front panel RF drive control to zero output. Place the Delta II in "TUNE" mode and adjust R19 for 500mA above idle current.

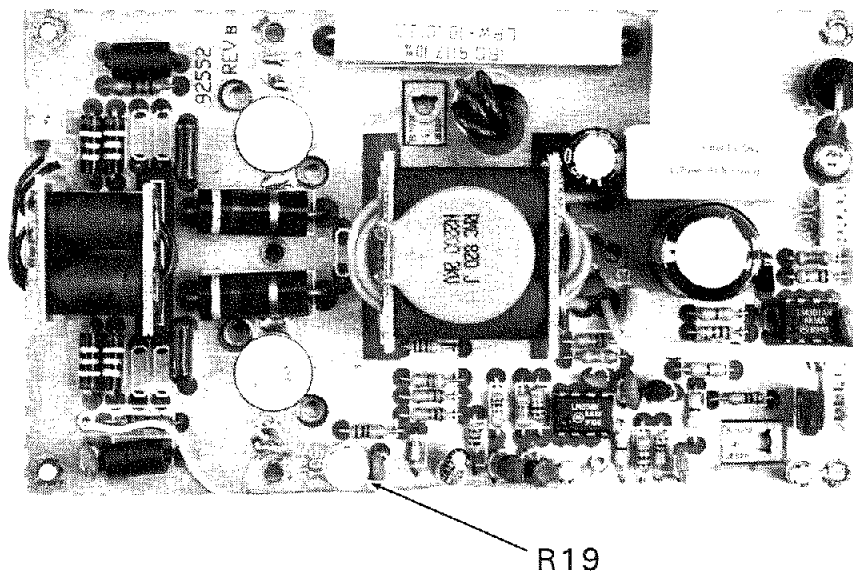
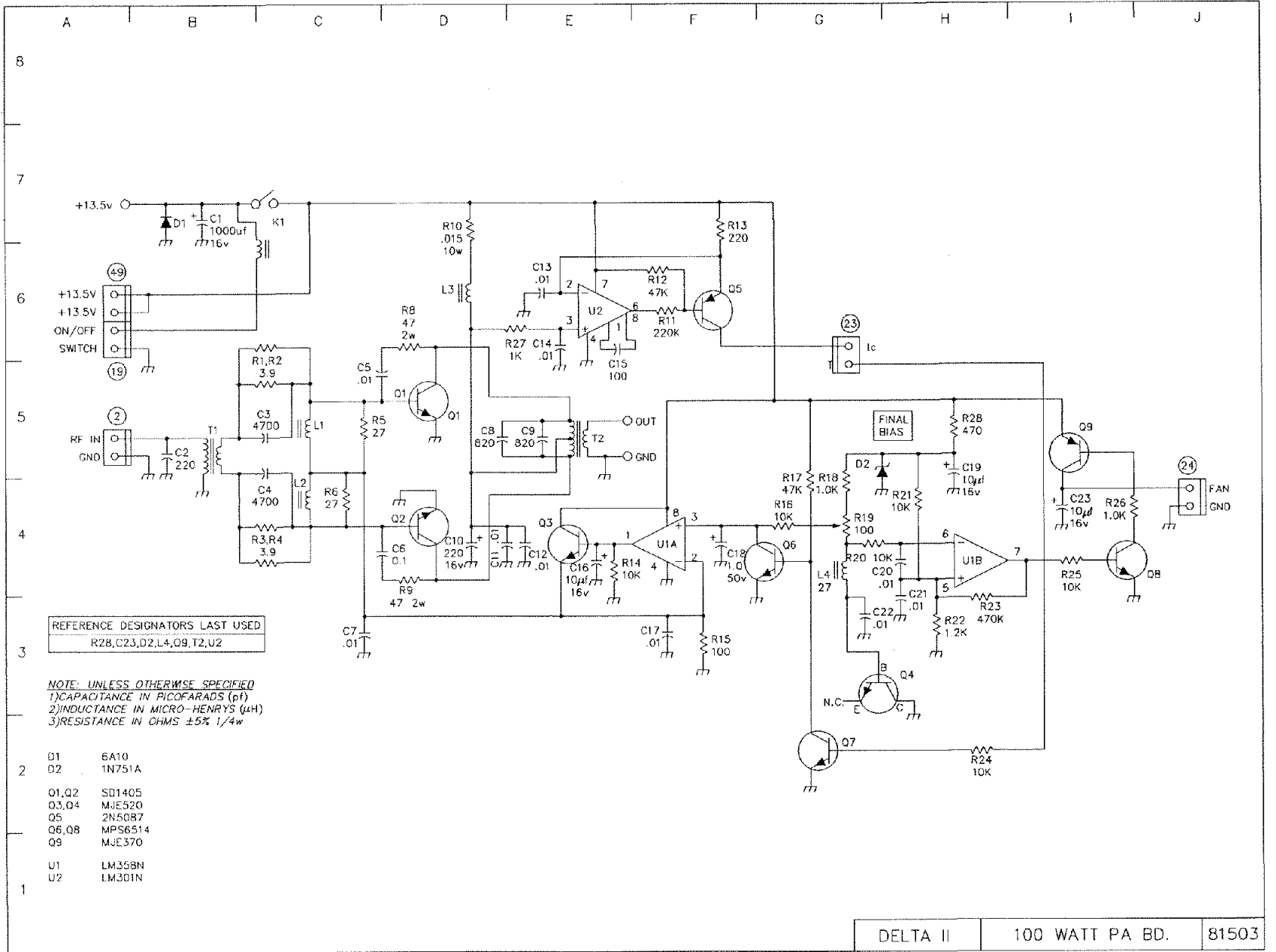

FIGURE 4-9. 100 WATT AMPLIFIER BOARD COMPONENT LAYOUT (81503)

FIGURE 4-10. 100 WATT AMPLIFIER BOARD SCHEMATIC (81503)



4-7 TRANSMIT AUDIO BOARD (81506)

The TX Audio board contains the microphone amplifier, speech processor, clipper-filter, balanced modulator, VOX circuitry and the CW/SSB switching.

Microphone Amplifier

Integrated circuit U1A amplifies the microphone audio (connector 39). FM pre-emphasis (connector S) is obtained by selecting an R/C time constant in the microphone amplifier feedback loop. Speech processing (connector 44) increases the gain of the amplifier by 20 dB and activates an audio AGC circuit (Q1, Q2, and Q5). The gain is set just below the clipping point of D2 and D3. The clipper removes any overshoot that may occur in the processor. The signal is filtered (low pass filter U1B) to remove unwanted high frequencies. Modulation audio for the FM mode is available at connector 43 and adjusted by potentiometer R28. Front panel MIC GAIN (connector 38) provides the audio for the balanced modulator. The output of the filter also is used for the VOX circuits (U3, Q7 and Q8).

SSB Modulator

Integrated circuit U2 is a balanced modulator. The carrier signal (connector 35) is applied to pin 8 and the audio modulation signal to pin 4. In the CW mode, pin 4 is unbalanced with a positive voltage. SSB voltage present at connector 47 accomplishes the necessary switching between CW and SSB. In the SSB mode, voltage present at the SSB pin of connector 47 biases diode D13 connecting the arm of the MIC GAIN control to pin 4 and activates Q9 to remove the CW voltage from pin 4. In CW the SSB voltage is not present and the amount of unbalance (CW output) is set with control R32 at 1.8MHz. The output of the balanced modulator is buffered and amplified in Q15 before being routed to the filter switching circuits.

Alignment:

CARRIER. Connect a suitable dummy load to the antenna connector. Switch the transceiver to 29 MHz and push the TUNE button. With the PWR control set maximum clockwise, adjust the carrier potentiometer, R32 for a maximum clean CW wave form with the ALC LED on.

CARRIER BALANCE. Connect an oscilloscope to the output and the mode to USB. Close the PTT line and adjust R81 for minimum carrier.

FM MODULATION. Apply an audio frequency of 1000 Hz to the microphone input and adjust the level to 50 mv. Using a deviation meter, set potentiometer R28 for a deviation of 5 KHz.

AUDIO PROCESSOR. Apply an audio frequency of 1000 Hz to the microphone input and adjust the level to 50 mv. Turn on the processor and, with an oscilloscope connected to the cathode of D3, adjust R16 until the sine wave is just below the clipping point.

Filter Switching

In the CW mode, the crystal ladder filters are not used. Diodes D10, D11, and D12 are biased on from voltage present at connector 36. Diodes D8 and D9 are reverse biased, disconnecting the filter. The CW signal is passed through the diodes and amplifier Q13 to output connector 33. In the SSB mode, diodes D8 and D9 are biased on by Q10 and the double side band signal is routed to the filter board through connector 45. the return signal is applied to connector 46 and on to Q13 and the output connector 33.

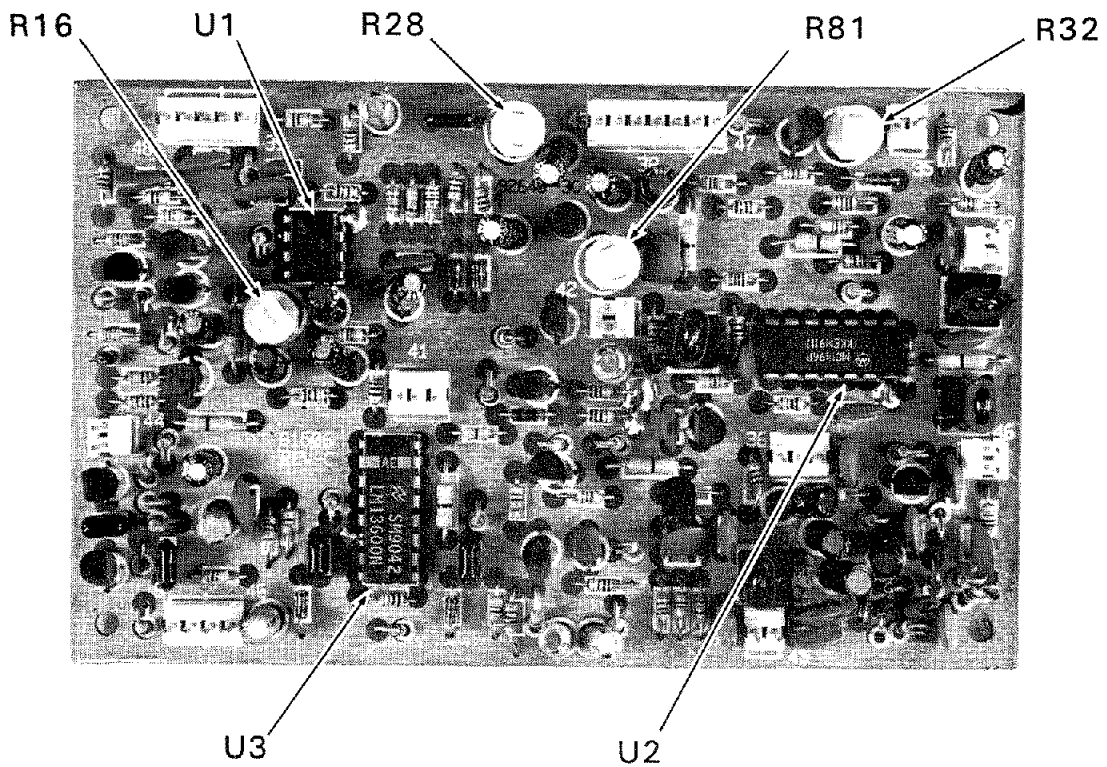
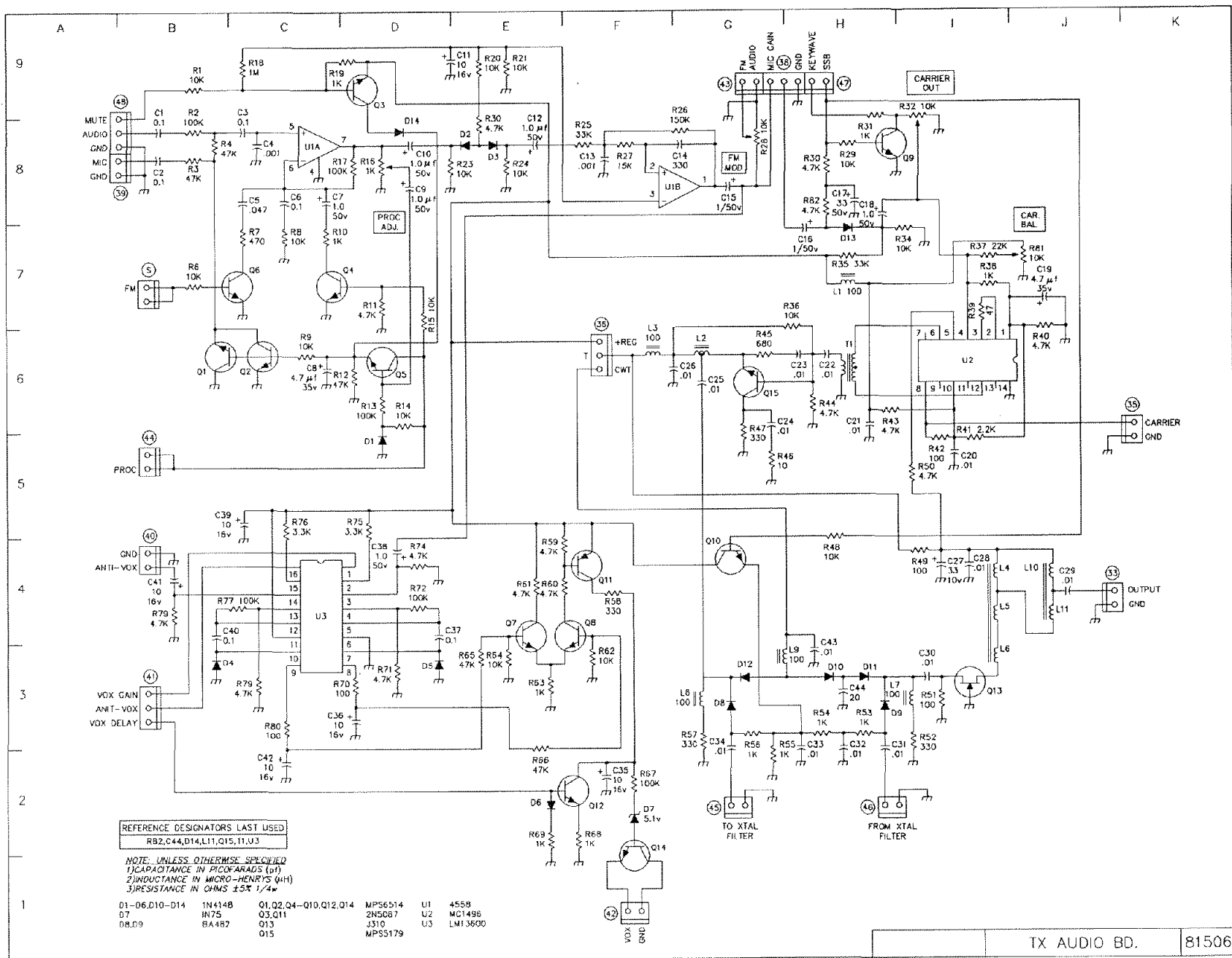

FIGURE 4-11. TRANSMIT AUDIO BOARD COMPONENT LAYOUT (81506)

FIGURE 4-12. TRANSMIT AUDIO BOARD SCHEMATIC (81506)



4-8 TRANSMIT MIXER BOARD (81507)

Mixer

The TX Mixer board combines signals from the carrier generator, second injection oscillator and the first injection oscillator to produce the wanted frequency. It also contains the necessary circuitry to provide ALC control. The FM signal is applied to connector 32, the SSB/CW signal is applied to connector 33. Control voltages from the Logic board are available at connector 34 to select the desired mode. Diodes D3 and D4 form an attenuator that is used to control the gain of the transmit chain (ALC). The signal is then mixed with the second conversion oscillator present at connector 26. The resultant 45 MHz signal is amplified in Q2 and filtered in L8, L12, and L13. The 45 MHz signal is then mixed with the first conversion oscillator, present at connector 25, the resultant frequency is amplified in Q3 and Q4. The filtered signal is available on connector 14.

Alignment: Disconnect the TX Mixer output (connector 14). Connect a spectrum analyzer to the output tap on L13 (TP on board). Put the transceiver in TUNE and adjust L8, L12 and L13 for maximum signal at 45 MHz. Output should be approximately -10 dBm.

ALC

Forward and reflected voltages, from the SWR bridge on the Low Pass Filter Board, are available at connector 5. The reflected voltage is applied to Q8 and the buffered output to connector 28. Potentiometer R33 calibrates the SWR read on the meter. The forward

voltage is buffered in Q6 and Q7. The output of Q6 is available on connector 28. Potentiometer R34 calibrates the forward power meter. Capacitor C18 and R25 form the ALC time constant. The ALC voltage is compared with a preset voltage in U1A and the output controls the ALC attenuator. The preset voltage is adjustable from the front panel PWR control. The Power control plugs into connector 29. U1A compares the ALC voltage to a reference and drives the ALC light at connector 27. Connector 23 and diode D8 are used only in the Delta and sum the final collector current into the ALC attenuator as an over current protection feature.

ARGONAUT II Alignment: To set forward power, connect a wattmeter and dummy load to the transceiver output. Turn the PWR control full clockwise and adjust R11 for 5 watts at 14MHz. Adjust R34 until 9 bars are showing on the bar graph meter. Switch to REF and, with a 25Ω load, adjust R33 for a 2:1 SWR on the bar graph.

DELTA II Alignment: To set forward power, connect a wattmeter and dummy load to the transceiver output. Turn the PWR control full clockwise and adjust R11 for 100 watts at 14MHz. Adjust R34 until 9 bars are showing on the bar graph meter. Switch to REF and, with a 25Ω load, adjust R33 for a 2:1 SWR on the bar graph.

SETTING CURRENT LIMIT:

Attach a suitable dummy load to the antenna output, and tune to 14MHz. Insert an ammeter in series with a positive DC power lead. Pull connector 5. Press the button and adjust R24 for 22A on the ammeter.

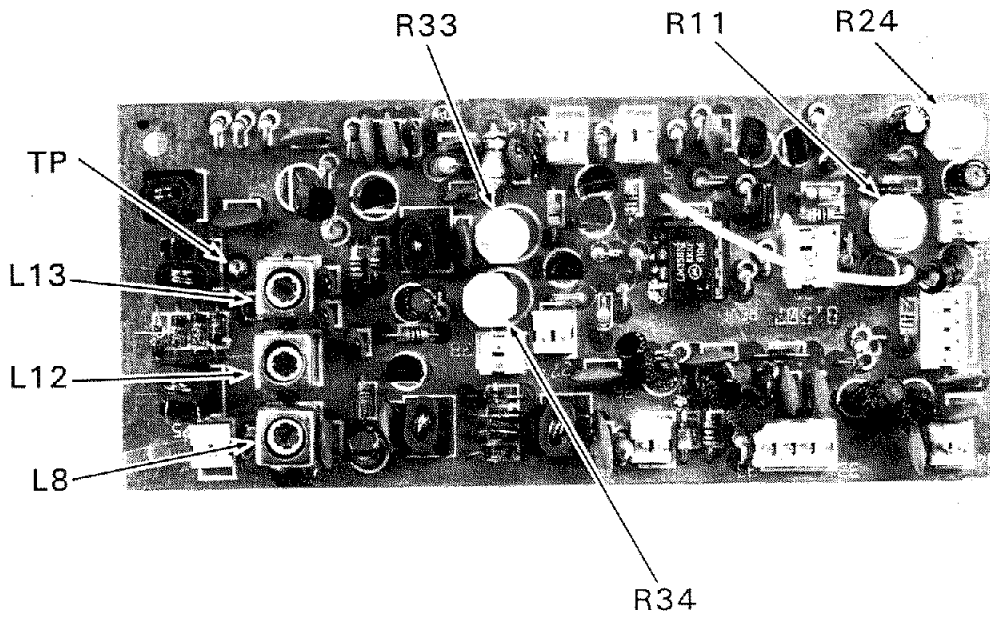
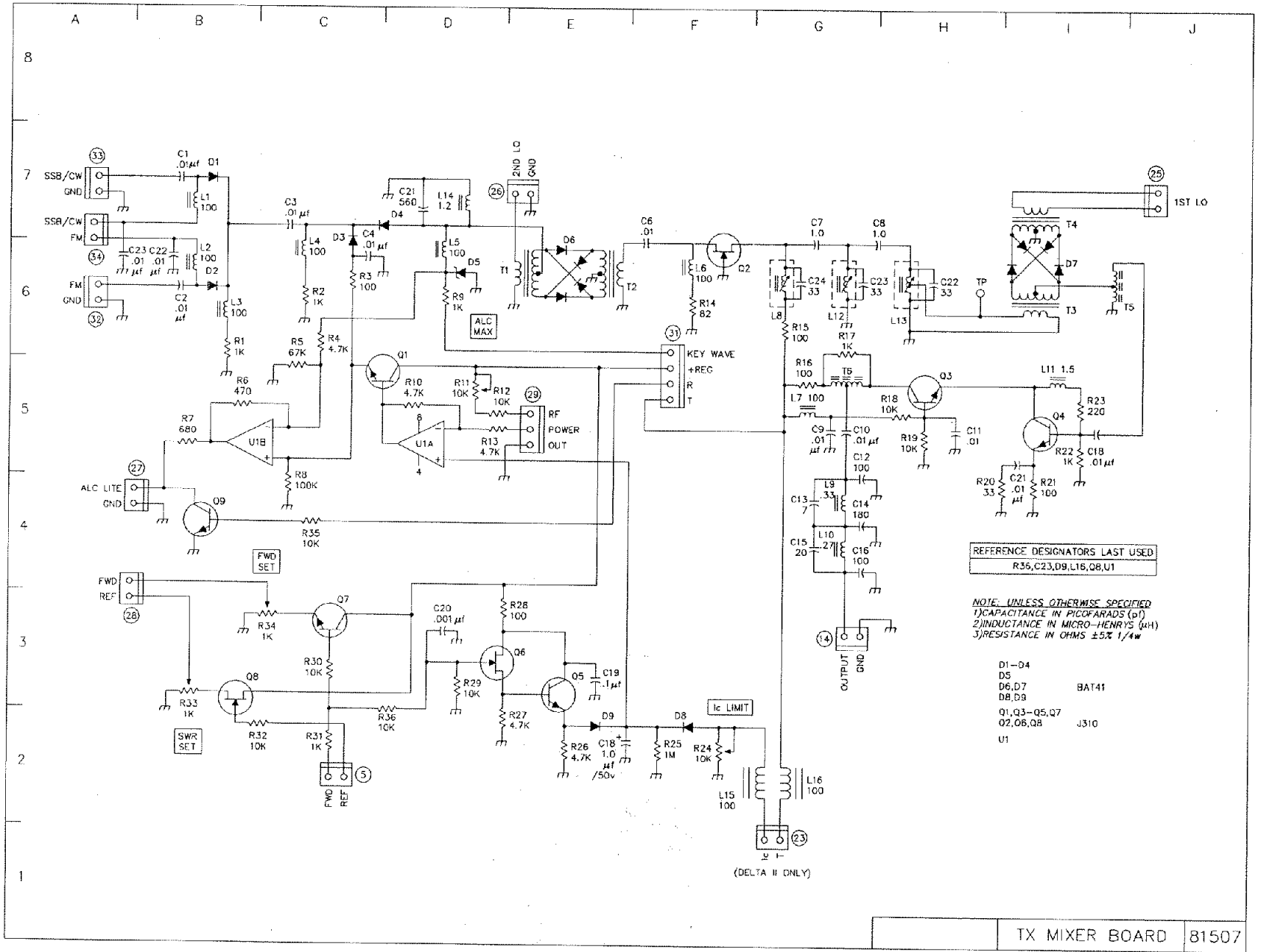

FIGURE 4-13. TRANSMIT MIXER BOARD COMPONENT LAYOUT (81507)

FIGURE 4-14. TRANSMIT MIXER BOARD SCHEMATIC (81507)



REFERENCE DESIGNATORS LAST USED
R35, C23, D9, L16, Q8, U1

NOTE: UNLESS OTHERWISE SPECIFIED
1) CAPACITANCE IN PICO FARADS (pF)
2) INDUCTANCE IN MICRO-HENRYS (μH)
3) RESISTANCE IN OHMS ±5% 1/4W

- D1-D4
- D5
- D6, D7
- D8, D9
- Q1, Q3-Q5, Q7
- Q2, Q6, Q8
- U1
- BAT41
- J310

TX MIXER BOARD 81507

4-9 DELTA II LOWPASS FILTER BOARD (81508)

The DELTA II Low Pass Filter board uses a novel arrangement of six filter sections hooked end to end. The unfiltered output from the transmitter travels through the lowpass sections until a band select relay extracts the signal and routes it out through the SWR bridge and on to the antenna. One of six band select lines from the microprocessor activate the appropriate relay so that harmonics of the signal are filtered out.

Transmit/receive switching consists of reed relay K1 and diodes D1 and D2. During receive the relay opens to disconnect the low pass filters and R voltage at connector 6 turns on transistor Q2. Current from Q2 drives D1 and D2 to create a loss path from the antenna to the receiver front end at connector 4.

On transmit, K1 connects the transmitter output to the antenna. Meanwhile the voltage doubler diodes D2-D6 generate a large nega-

tive voltage from the transmitter signal. This voltage reverse biases D1 and D2 to keep them turned off. The small amount of transmit signal that does leak across the diode switch gets shunted to ground by Q1.

Transformer T1 combines a current sample from the one turn link primary and a voltage sample from the capacitive divider of C12 and C13. The output of T1 is rectified and filtered to generate two DC outputs that indicate forward and reflected power. These outputs at connector 5 drive the front panel meter and provide feedback for the output leveling ALC loop.

Alignment: Set the transmitter to 14 MHz. Connect a DC voltmeter to REF on connector 5 of the TX Mixer board 81507. With an insulated tuning tool, adjust C12 on board 81508 (low pass filter board) for a minimum reading.

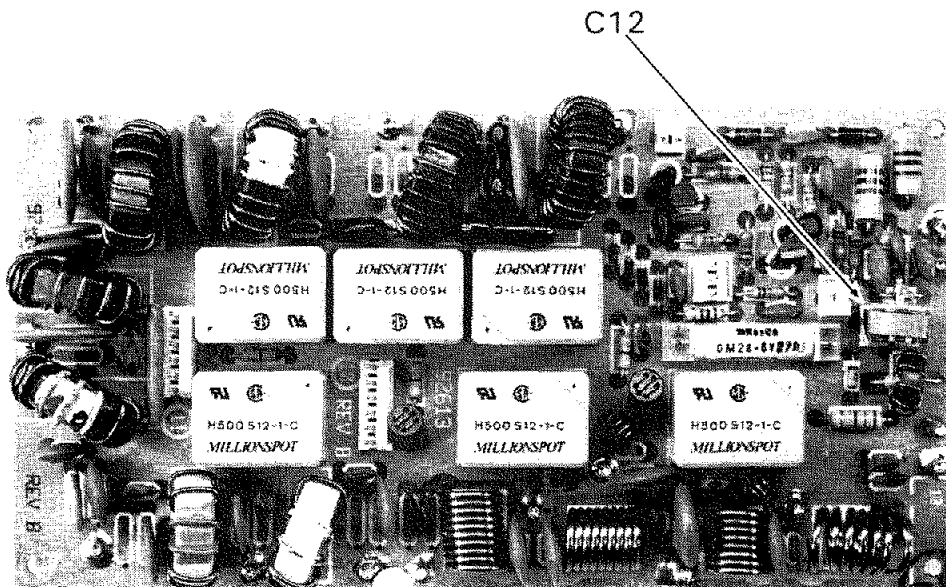
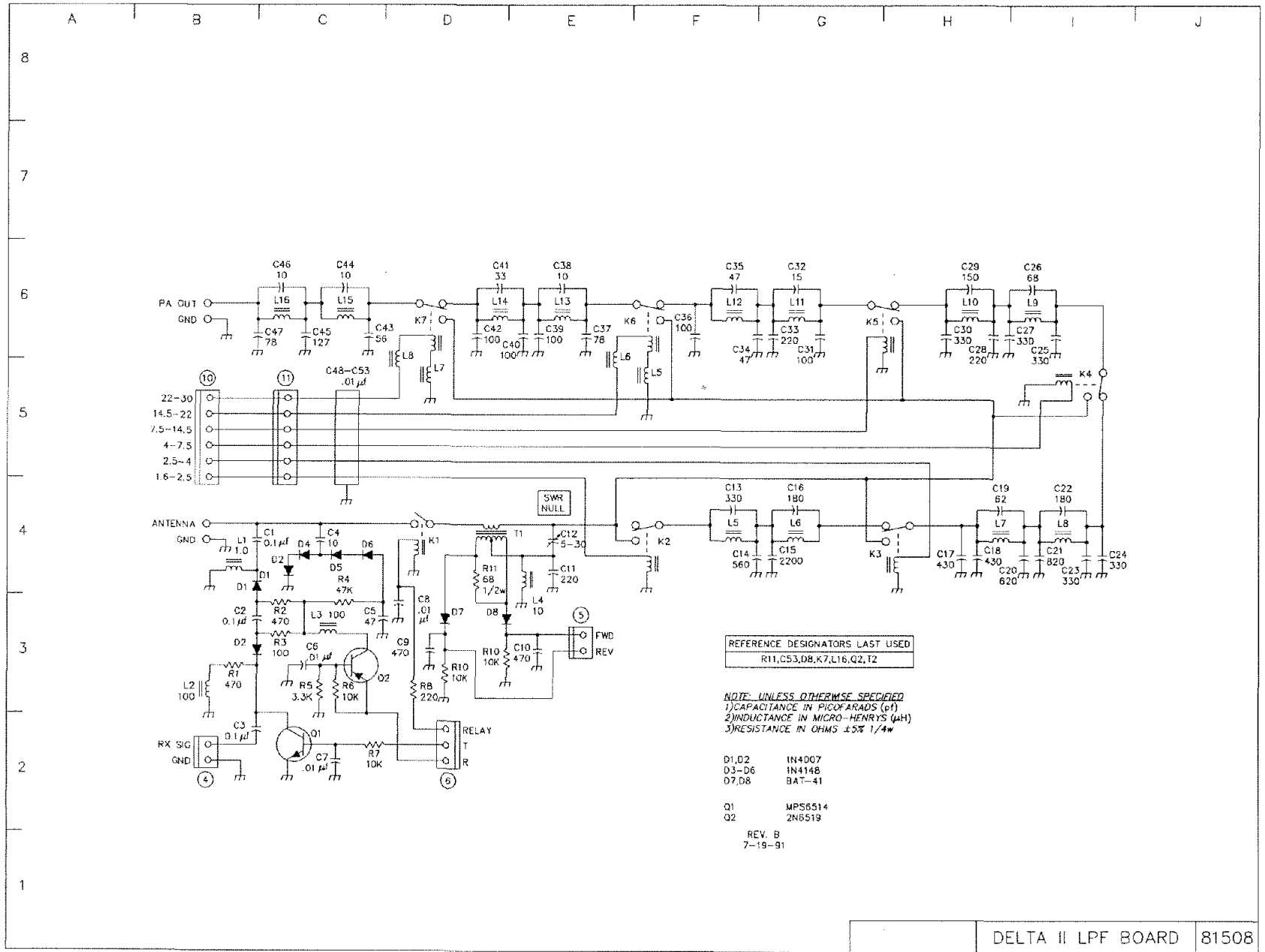

FIGURE 4-15. DELTA II LOWPASS FILTER BOARD COMPONENT LAYOUT (81508)

FIGURE 4-16. DELTA II LOWPASS FILTER BOARD SCHEMATIC (81508)



HEAR BOTH SIDES OF WORLD EVENTS

RX-340

USED BY GOVERNMENTS WORLDWIDE!

HF SWL receiver, 5 kHz – 30 MHz. IF stage DSP. Sync AM/selectable sideband, SAM, AM, SSB, ISB, CW, FM. Over 90 bandwidth filters, programmable AGC, built-in high stability TCVCXO. Completely remote controllable via RS-232 interface. DRM ready, no modification needed (user supplies decoding software). 90-264 VAC operation. **\$4,250**

RX-320D

LISTEN TO THE WORLD ON YOUR PC!

General coverage from 100 kHz – 30 MHz. "Black box" receiver connects to your PC via one serial port. Your PC provides the operation horsepower. A 12 kHz I-F output is included for decoding DRM transmissions with your PC sound card (user supplies decoding software). Download the actual operating software from our website for a pre-purchase test drive. **\$359**

1254

KIT BUILDING IS A WORLD OF FUN!

Build your own HF SWL receiver with our model 1254 shortwave receiver kit. 500 kHz – 30 MHz coverage in 2.5 kHz steps with clarifier control allowing tuning of all frequencies. LED digital readout. AM, SSB, CW capable. Complete step-by-step instructions and all components included. See our website for information on other available kits! **\$195**

1185 Dolly Parton Pkwy., Sevierville, TN 37862 800-833-7373 www.tentec.com

Mon-Fri 8:00-5:30 EST We accept Visa, MC, American Express, and Discover Office: (865) 453-7172 Service: (865) 428-0364



RX-340



RX-320D



1254

TENTEC

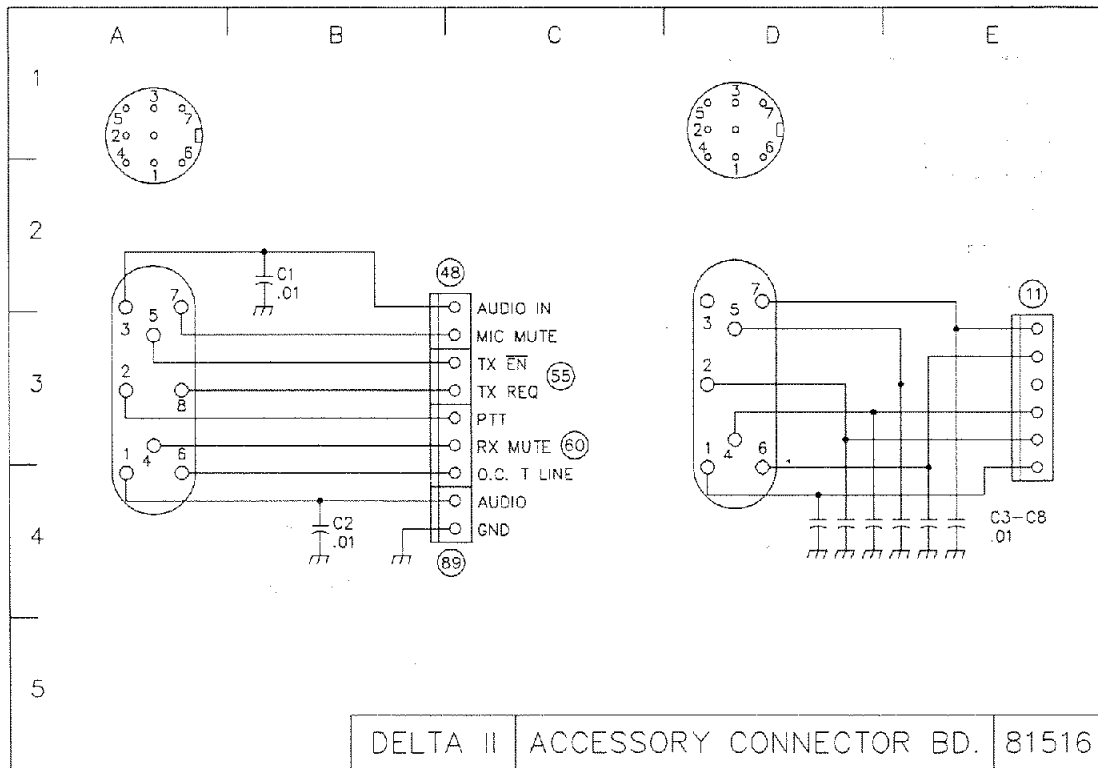

FIGURE 4-17. DELTA II ACCESSORY CONNECTOR BOARD SCHEMATIC (81516)

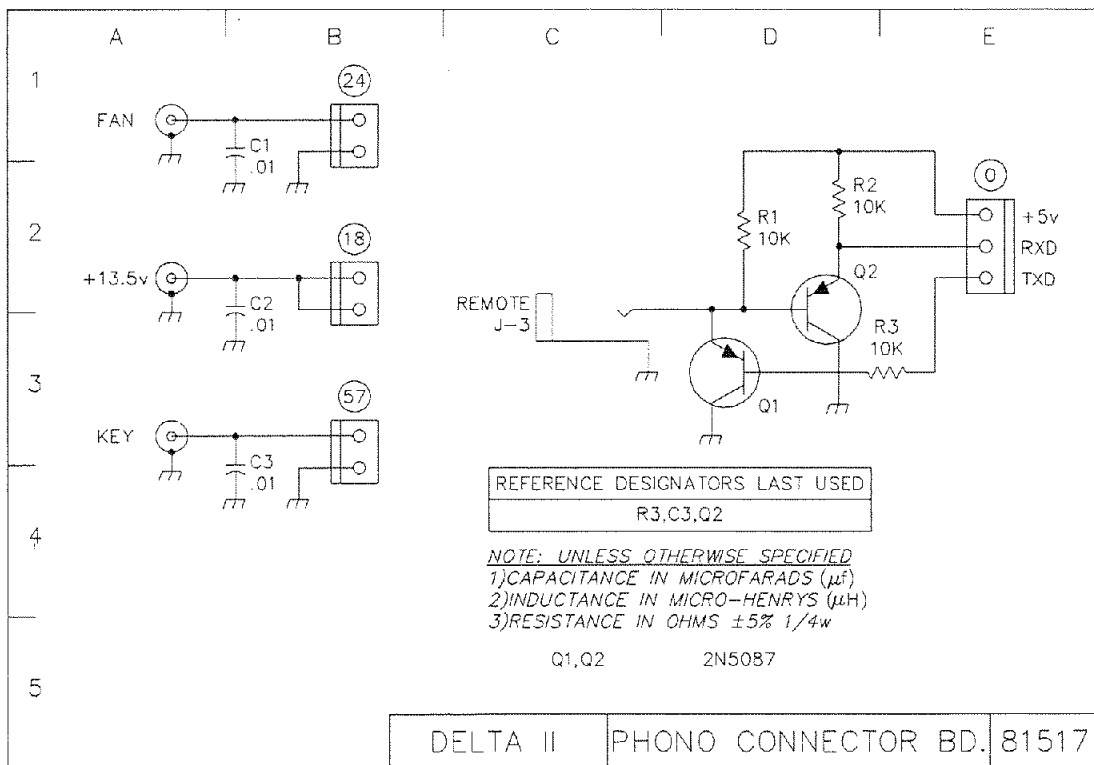

FIGURE 4-18. DELTA II PHONO CONNECTOR BOARD SCHEMATIC (81517)

4-10 SLIDE SWITCH BOARD (81518)

QSK FAST/SLOW
 AGC FAST/SLOW
 AGC ON/OFF
 ATTN
 LAMP (DIAL)
 SQL

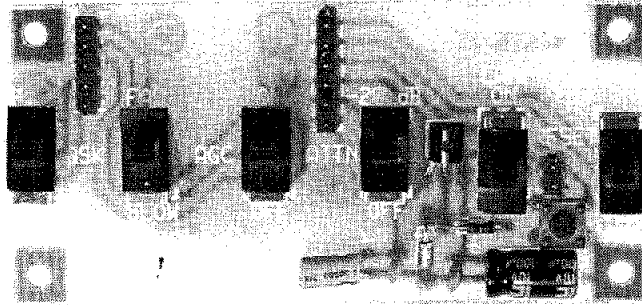

FIGURE 4-19. SLIDE SWITCH BOARD COMPONENT LAYOUT (81518)

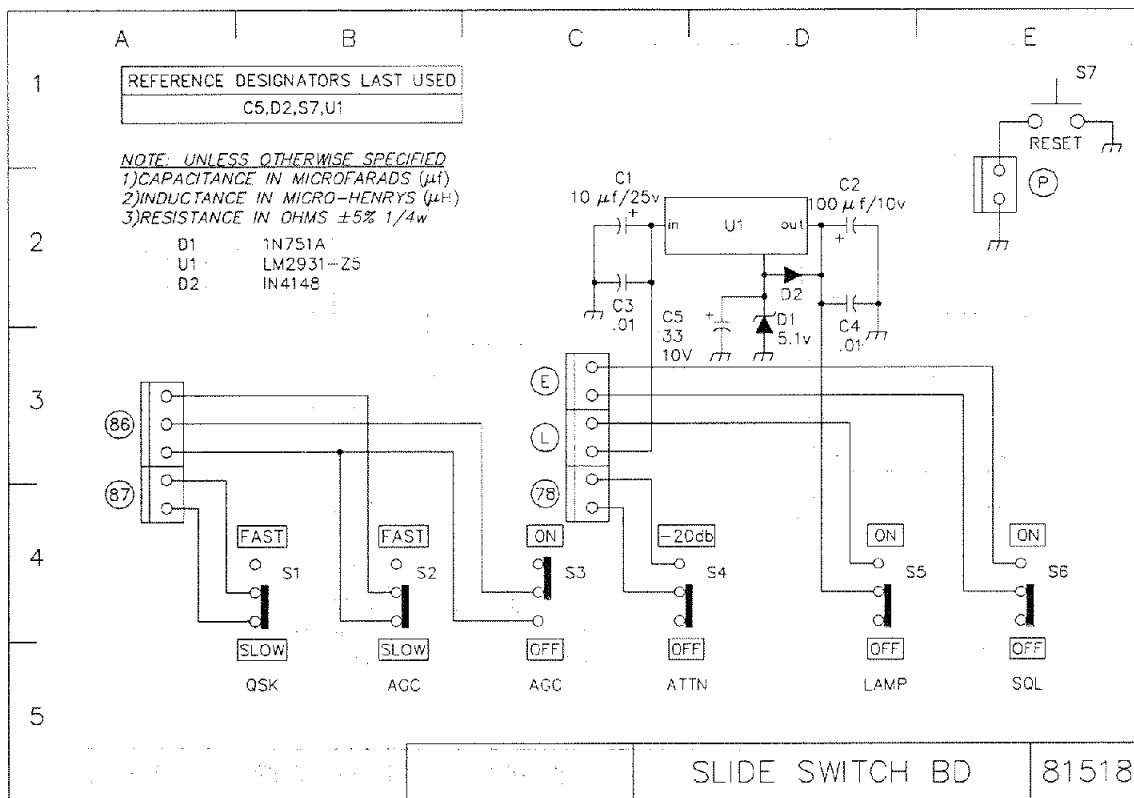

FIGURE 4-20. SLIDE SWITCH BOARD SCHEMATIC (81518)

4-11 PUSHBUTTON SWITCH BOARD (81520)
PROC ON/OFF
N.B. ON/OFF VOX/PTT
FWD/REF

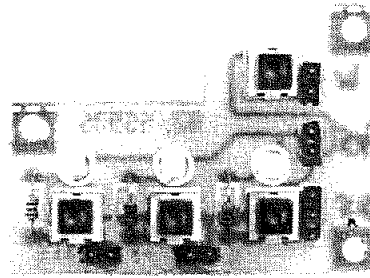

FIGURE 4-21. PUSHBUTTON SWITCH BOARD COMPONENT LAYOUT (81520)

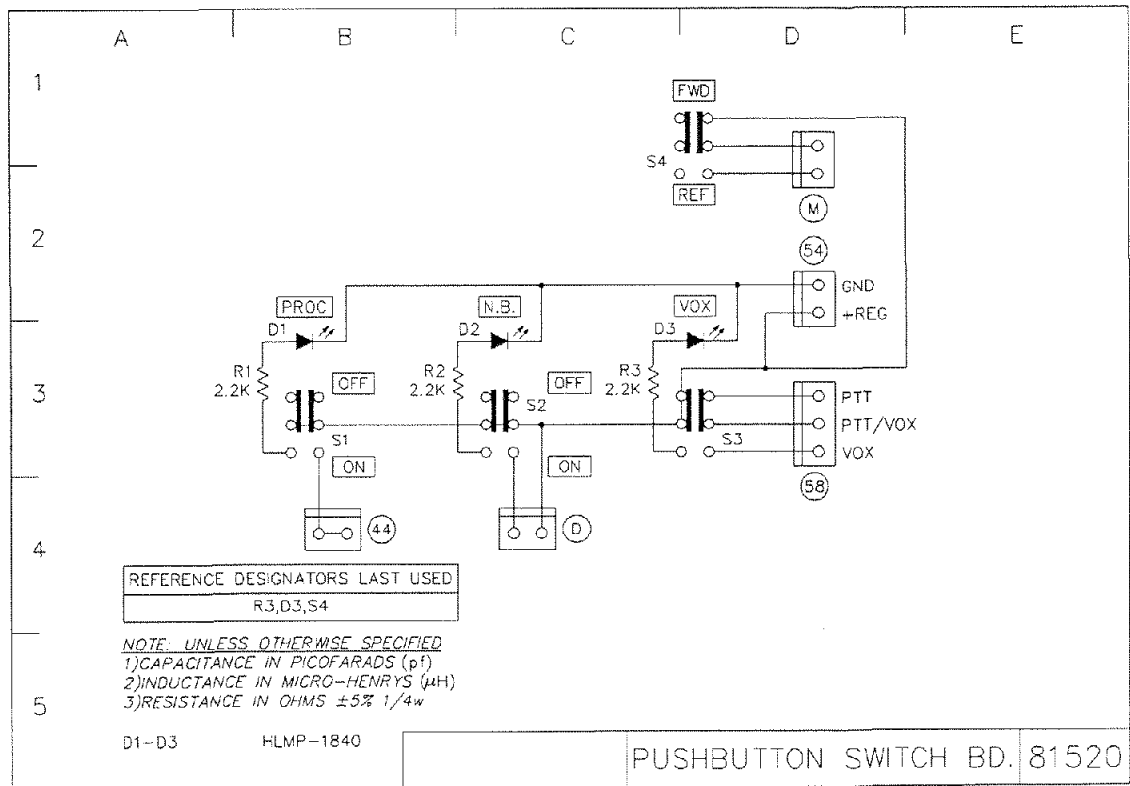

FIGURE 4-22. PUSHBUTTON SWITCH BOARD SCHEMATIC (81520)

4-12 ARGONAUT II TRANSMIT LOWPASS FILTER BOARD (81521)

The low pass filter board selects the proper filter for reduction of harmonics, provides a bridge for forward/reflected power readings and does the T/R switching.

FILTER SELECTION: RF power from PA board 81502 is applied to connector 2. The frequency spectrum between 1.8 MHz and 30 MHz is split into 6 bands. Each band has a low pass filter, selected by signals from the Logic Board, to remove the unwanted harmonics. Diodes D4 through D15 select the filters. Diodes D1, D2, and D3 form a voltage tripler, powered from the RF input, that produces a DC voltage which is used to back bias the unused switching diodes.

SWR BRIDGE: Bridge transformer T1 provides a voltage proportional to the forward and reflected power. These voltages are used

for control of the ALC function and are available at the meter as an indication of the forward power and the load SWR.

Alignment: Set the transmitter to 14 MHz. Connect a DC voltmeter to REF on connector 5 of the TX Mixer board 81507. With an insulated tuning tool, adjust C41 on board 81521 (low pass filter board) for a minimum reading.

T/R SWITCHING: Transistors Q7, Q8, diodes D16, D17 and relay RY1 provides the T/R switching function. During transmit a high negative voltage, from the voltage tripler, is fed to the junction of D16 and D17 essentially opening the path from the antenna connector to the receiver. Transistor Q8 shunts the receiver input improving the isolation between the transmitter and receiver input. During receive, R voltage, by way of transistor Q7, biases the diodes on providing a path from receive to the antenna connector.

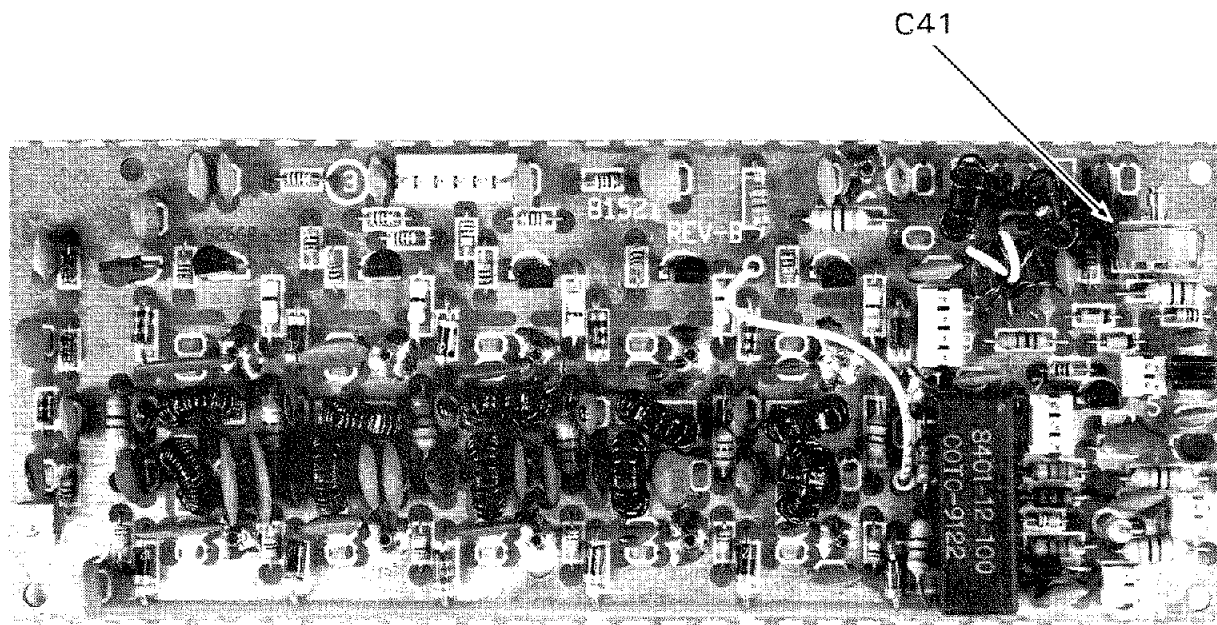
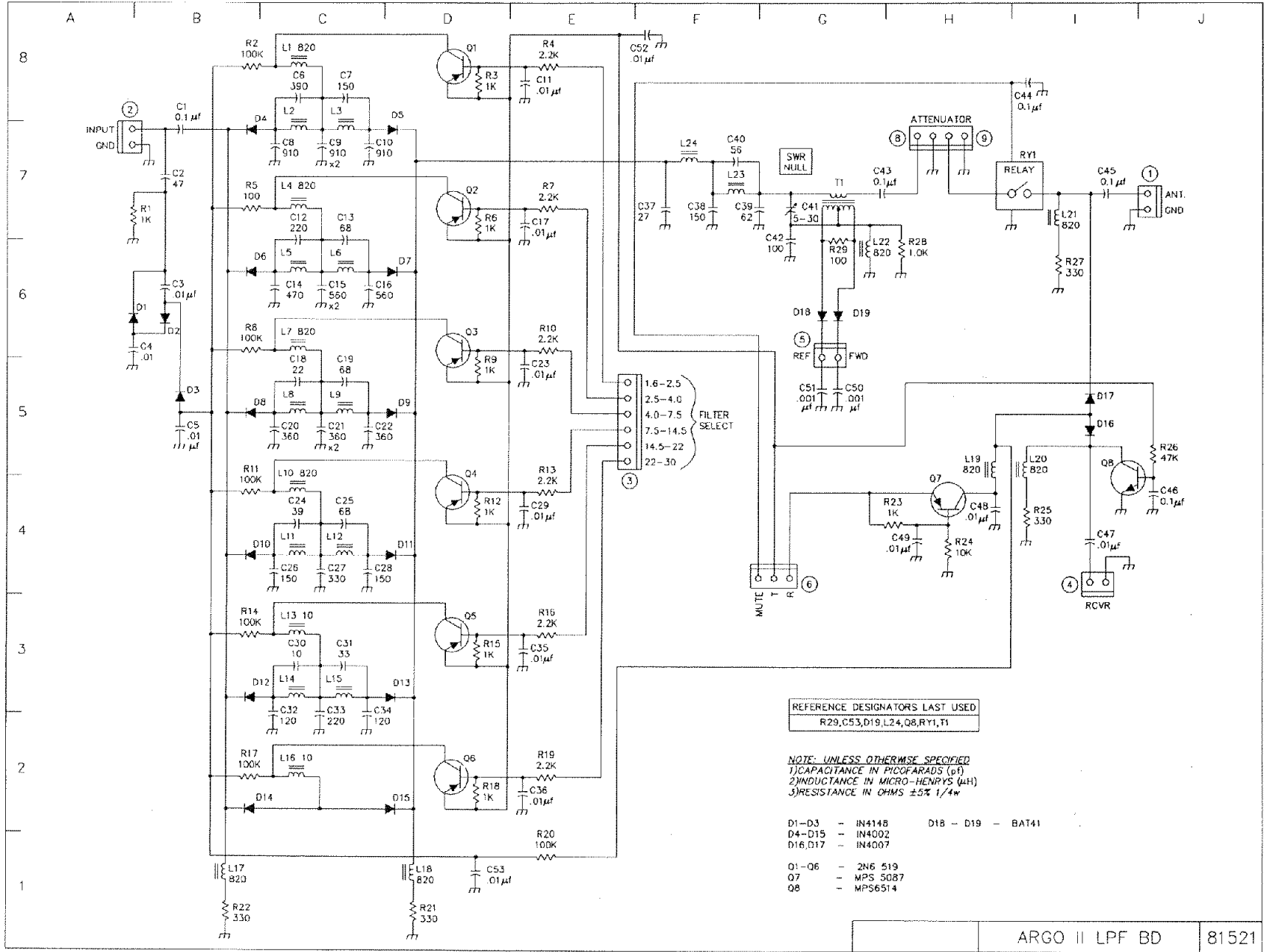

FIGURE 4-23.
TRANSMIT LOWPASS FILTER BOARD COMPONENT LAYOUT (81521)

FIGURE 4-24. TRANSMIT LOWPASS FILTER SCHEMATIC (81521)



4-13 UPPER POT BOARD (81522)
NOTCH
RXO (Receive offset tuning)
PBT
IF BW

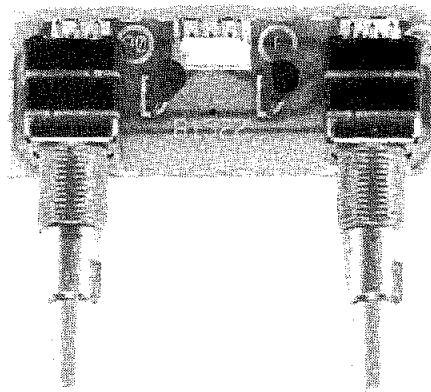

FIGURE 4-25. UPPER POT BOARD COMPONENT LAYOUT (81522)

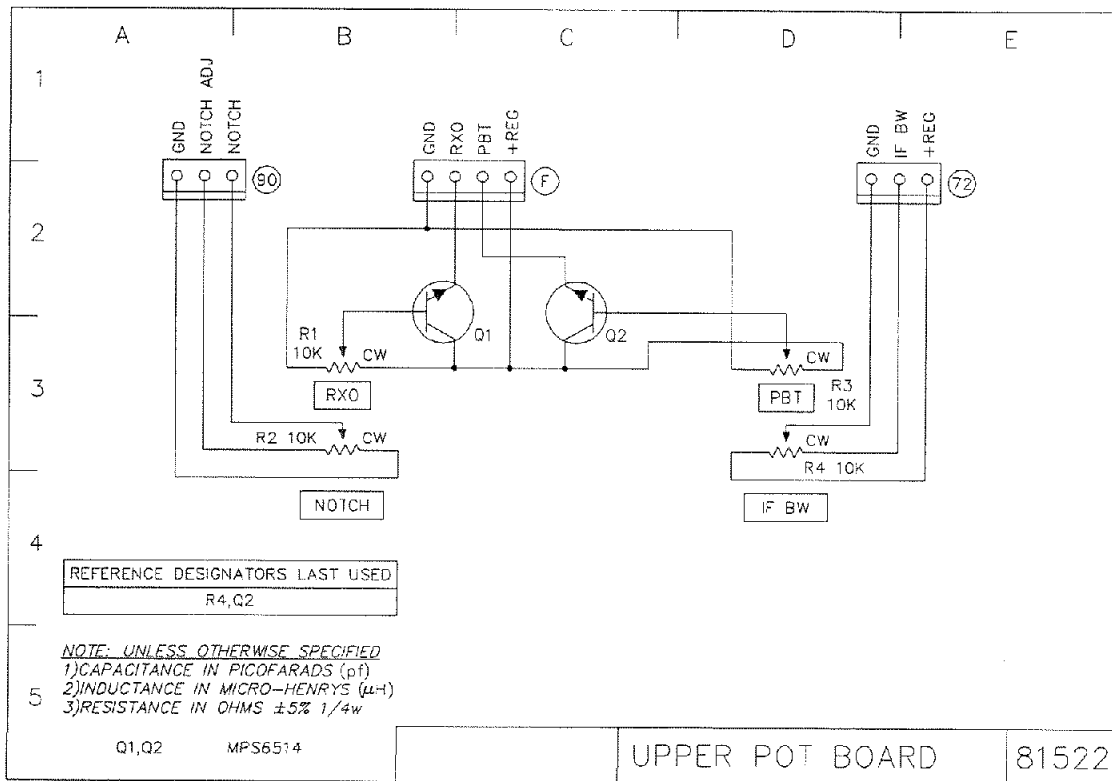

FIGURE 4-26. UPPER POT BOARD SCHEMATIC (81522)

4-14 LOWER POT BOARD (81523)
 AFGAIN, RFGAIN
 ALC LED
 MIC GAIN
 PWRADJ

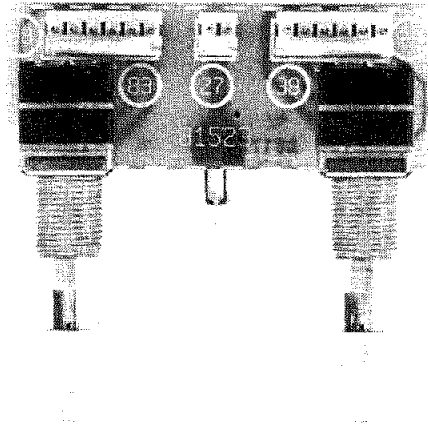

FIGURE 4-27. LOWER POT BOARD COMPONENT LAYOUT (81523)

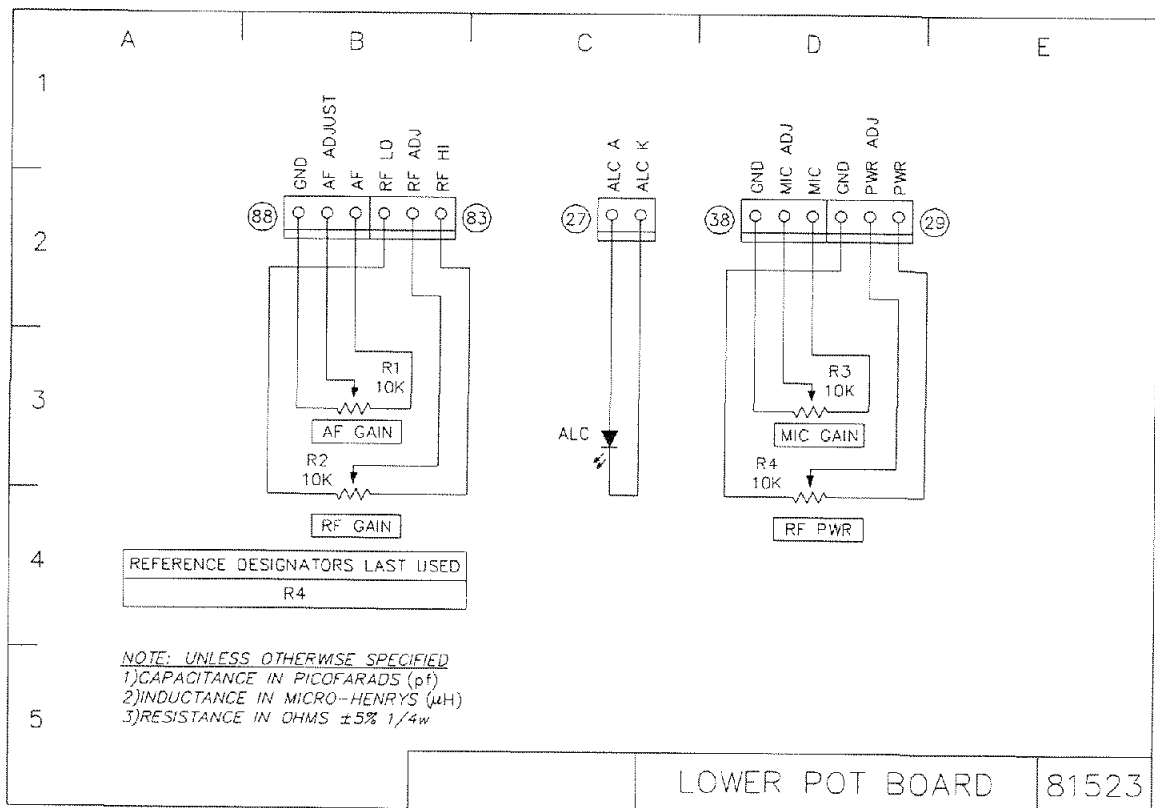

FIGURE 4-28. LOWER POT BOARD SCHEMATIC (81523)

4-15 SECOND MIXER / NOISE BLANKER (81524)

A balanced mixer converts signals from the first IF of 45 MHz to 6.144 MHz, provides an output for the noise blanker amplifiers and contains the noise blanker gate.

The 45 MHz signal (connector 76) from the first mixer is matched to the filter FL1 by L1, C2, and C1. The filter output is matched with L2, C3, and C4 to the input circuit of the balanced mixer (Q1 and Q2). The 2nd conversion oscillator (connector 98) is applied to the source of Q1 and Q2. Balance is obtained with the potentiometer in the source. The output is tuned to 6.144 MHz and is routed through the grounded gate amplifier Q3. The amplified output is then routed through buffer Q4 to connector 75. It is also routed to the tuned circuit L6, C17, and C18. T1, T2, and diodes D1 through D4 form the noise blanker gate.

The diodes are forward biased from the pulse generator on the Noise Blanker board 81544 through connector 77. When a noise pulse is formed, the voltage at connector 77 drops to zero and the diodes are reverse biased by the voltage divider R13 and R14. Output for the 2nd IF board 81527 is through connector 71.

Alignment: Connect an AC voltmeter to the audio output of the transceiver. Connect a signal generator (14.000MHz, USB) to the antenna and set the frequency and output for a reading of 10dB above the noise. Tune L1, L2, L3, L4, L5 and L6 for maximum on the meter. Reduce the generator output as needed to keep the audio signal approximately 10 dB above the noise. Connect a spectrum analyzer to connector 71. Increase signal generator until signal appears on the spectrum analyzer. Adjust R2 until the second LO frequency (38.8542MHz) is nulled.

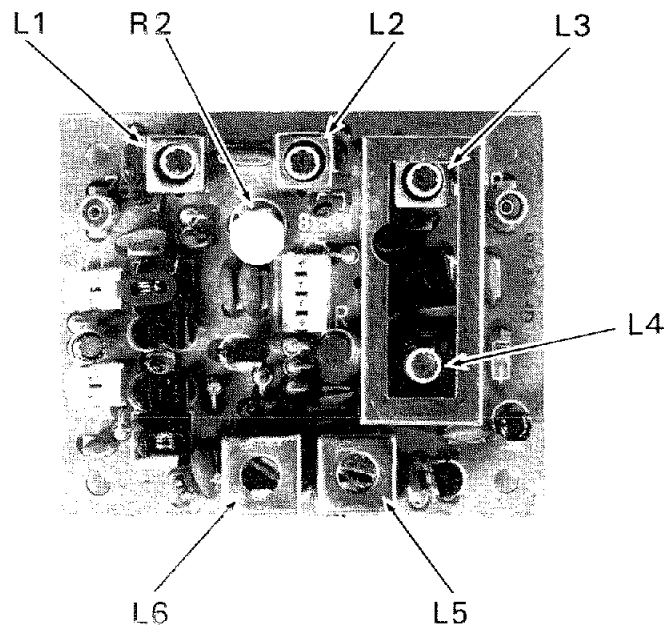
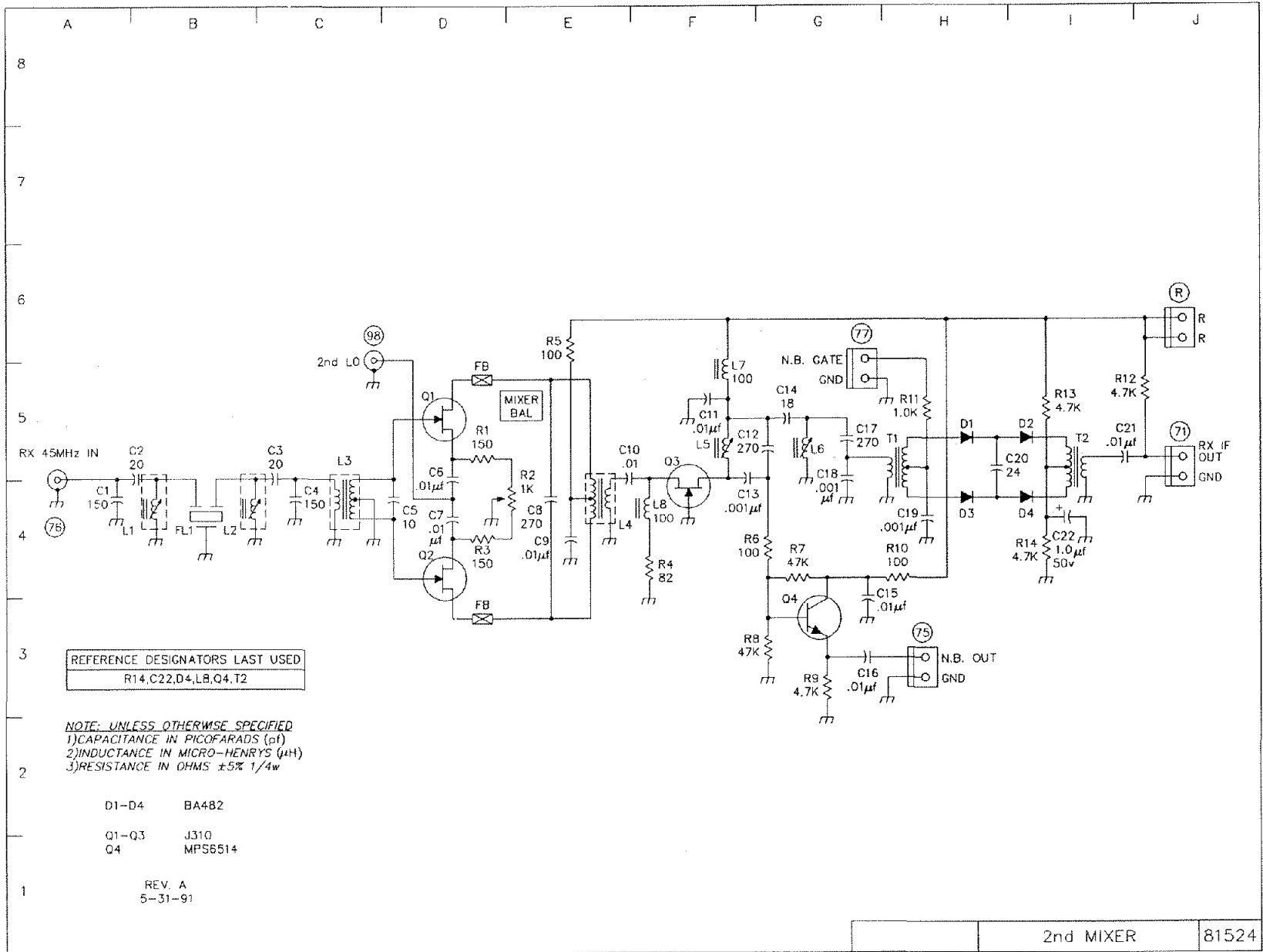

FIGURE 4-29.
SECOND MIXER / NOISE BLANKER COMPONENT LAYOUT (81524)

FIGURE 4-30.
 SECOND MIXER / NOISE BLANKER SCHEMATIC (81524)



4-16 IF / AF BOARD (81525)

The I.F. Audio board accepts a signal at a frequency of approximately 6.144 MHz, amplifies it, detects it and sends it through the various processors to the audio power amplifier. The board also contains the side-tone circuit for CW and the necessary AGC circuitry.

IF/AGC

The 6.144 MHz IF signal enters at connector 74 and is amplified by grounded gate FET Q1, integrated circuit IF amplifiers U1 and U2, and emitter follower Q2. The output of Q2 drives both the product detector and the AGC circuits. Diodes D3 and D4 develop an AGC voltage from the IF signal. The AGC voltage is level shifted by zener diode D5 so that gain reduction in U1 and U2 will start as soon as an IF signal is present. The AGC voltage is buffered by Q4 so that the attack time is preserved when charging AGC time constant capacitors C24 and C25. Fast AGC is available with capacitor C25. Connecting the negative terminal of C24 to ground through connector 86 provides slow AGC and grounding the base of Q9 removes all AGC. The AGC line is connected to U10A where it is compared to a preset voltage and the output of the comparator drives either Q5, which adds additional AGC in the IF, or Q7 which reduces the gain of the first RF amplifier when in the AM mode. The preset voltage is set by R15.

Alignment: IF: Set the transceiver to 14.000 MHz and connect a signal generator, set for 14.000 MHz, to the antenna connector. Connect a meter to measure the audio output. Remove AGC (switch on top cover) and apply enough signal to obtain a reading on the audio meter. Adjust L3 and L4 for a maximum reading. Be sure to reduce the signal from the generator, when necessary, to keep the audio reading below clipping.

Delayed AGC: Apply a 1.5mV, 30% modulation signal to the input of the transceiver and, with a voltmeter on the collector of

Q5(cathode of D1), adjust R15 until the voltage starts to drop. This voltage should be set at 8.0 volts. This will insure complete quieting of U1 and U2 before the delayed AGC is activated. (Note: the S-mtr must be recalibrated after any adjustment to R15)

S-MTR

The DELTA II S-meter is a bar graph design. The AGC voltage is amplified in U10B and sent to the Logic Board via connector 85. The Logic Board has a look-up table that is compared to the voltage received from U10B and lights the correct number of segments on the meter.

Alignment: Apply a 50 microvolt signal to the antenna connector and adjust R93 for S 9 on the bar graph.

AM Detector

The AM signal is taken from the output of U2. Transistor Q3 operates as the AM detector. Q3 is an emitter follower detector biased to the point of conduction by D2. The output is a reproduction of the positive portion of the AM carrier. Capacitor C23, C31, C32 and resistors R26-R29 filter the carrier and set the audio frequency response.

Product Detector

The product detector, U3, is used to demodulate SSB and CW signals. The BFO is applied to pin 2 of U3 via connector 93. The IF signal is from a resistive divider, R34 and R35, that sets the level for minimum distortion. The output of U3 is filtered to remove the IF frequencies and set the audio pass band. The resultant signal is available for the SSB mode and is also sent to an additional filter for CW. U4A and U4B form a 1KHz low pass filter for CW. This removes much of the high frequency hiss and noise making it more pleasant to copy CW.

Mode Selector

U5A, U5B, U5C and U5D are solid state switches operated by the Logic Board (connector 91). It selects either the AM, SSB, CW or FM signal and passes it on the audio stages.

Notch Filter

The output from the mode switch integrated circuit, U5, feeds a switched capacity notch filter, U6 and U7. The frequency of the notch is set by the front panel control via connector 90. The control adjusts the clock frequency of U6 which determines the notch frequency.

Audio Amplifier

Output from the notch arrives at the audio amplifier after passing through the volume control (connector 88). Audio output is split between either the speaker/phones (connector 84) or the anti-vox circuit (connector 40).

CW Sidetone & Alignment

CW offset (the difference between the transmit and receive frequency) is determined by the microprocessor and, in this transceiver, is set to 700 Hz. The sidetone is generated in U8A, and keyed by Q12 and U8B. The frequency of the sidetone is set by control R72 and the jumper in the ST socket. This is an internal adjustment and should be set to the CW offset frequency of 700 Hz. The range of the sidetone oscillator is approximately 400 Hz to 700 Hz. If you are not using dual VFOs in the

split mode, the sidetone may be used to net your transmit frequency to that of the station you wish to work. When in the CW mode, pressing the REV button will produce the sidetone without the transceiver going into transmit. Tune the incoming signal to match the sidetone frequency and you will be transmitting on the received signals' frequency. If you do not like to copy a 700 Hz cw note and don't care about the net function, simply remove the bottom and adjust potentiometer R72 and ST plug to a pleasant tone. If you wish to retain the spot tone feature, check the sidetone frequency that you have picked with a frequency counter and set the RXO control to the difference between the frequency you have chosen and 700 Hz. If you have picked a higher frequency, set the RXO control to the + side, if it's a lower frequency, set the control to the -side. Since RXO is defeated when you press the REV button it is important to remember to match the tones by momentarily pressing the REV button and not to match the tones while the REV button is pressed.

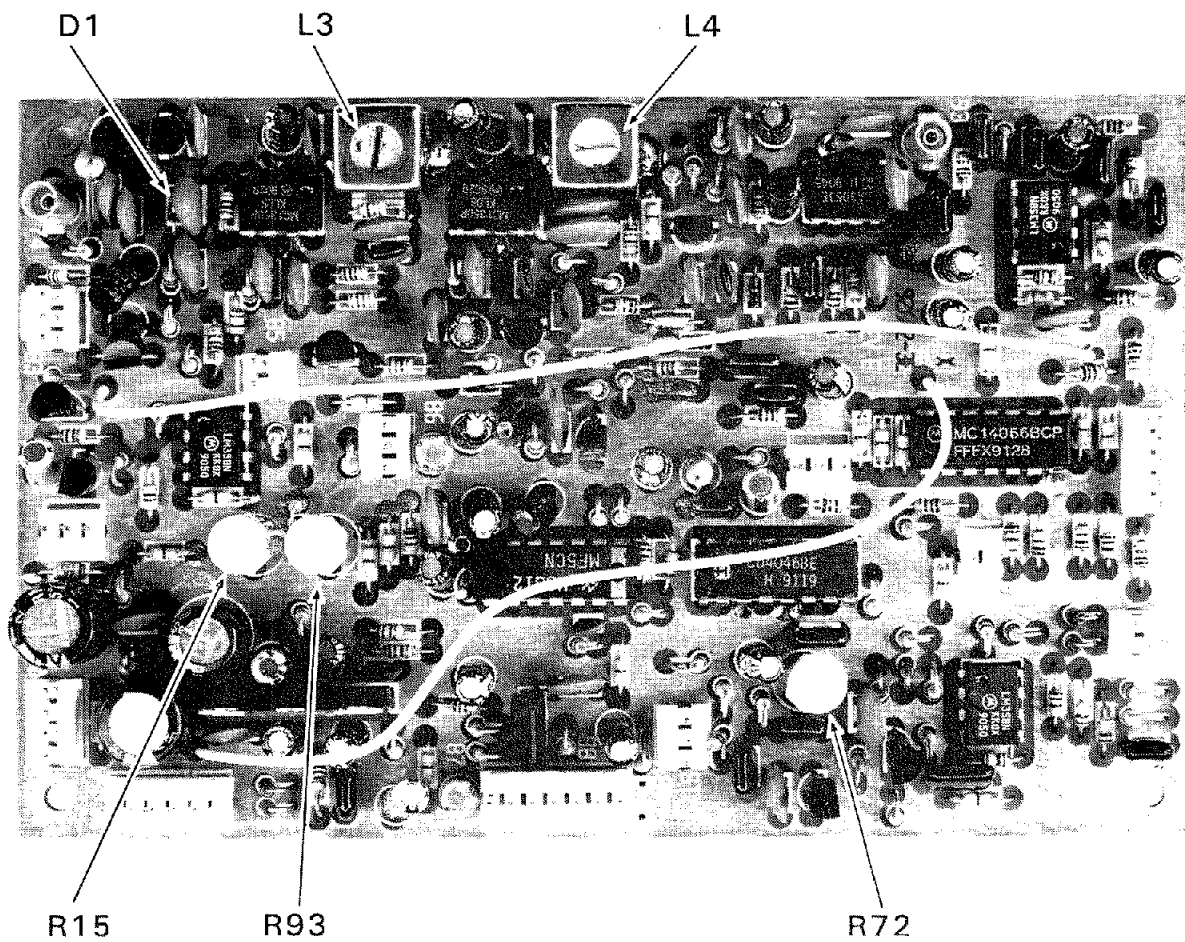
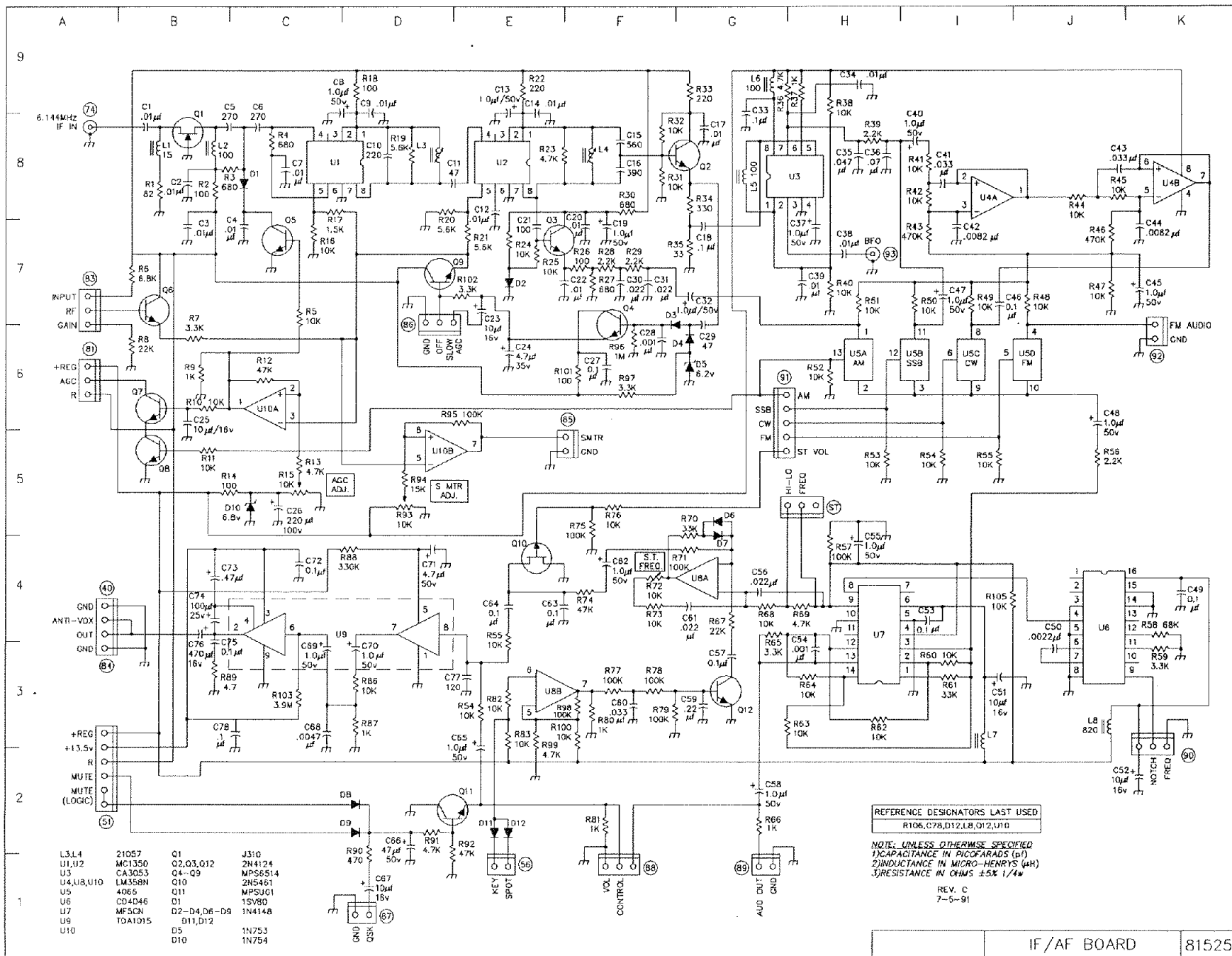

FIGURE 4-31. IF / AF BOARD COMPONENT LAYOUT (81525)

FIGURE 4-32. IF / AF BOARD SCHEMATIC (81525)



4-17 BAND PASS FILTER / FIRST MIXER (81526)

This circuit module accepts the signal from the antenna, filters it, amplifies it and mixes it with the first conversion oscillator to produce an IF of 45 MHz.

BP Filter: The signal from the antenna is passed through a 30 MHz low pass filter (L1, L2, C2, C3, C4, C5, and C6) and a 1.5 MHz high pass filter (L3, L4, L5, L6, L7, C8, and C9) before being applied to the amateur band filters to eliminate any possibility of signals outside the amateur bands from causing interference. For .1 to 1.6 MHz general coverage receive, the signal is routed around the high pass filter and through another low pass filter before reaching the amplifier. The other amateur filters are selected by signals from the Logic Board (connector 79) and diode switches.

RF Amplifier: The RF amplifier consists of two J-310 FETs(Q1, Q2) in parallel in a grounded gate configuration. This produces

an amplifier with good intercept and low noise. Diode D18 is used to reduce the amplification on AM only.

Mixer: The mixer consists of two J-310 FETs(Q3, Q4) in a push-pull configuration with the gates connected in parallel. This produces a single balanced mixer with good dynamic range and low noise figure.

Alignment: Capacitor C4 is used to set a notch in the 45 MHz IF. Connect a signal generator to the antenna input and tune it around 45 MHz until a signal is heard. The output level may have to be increased to 100 micro volts or more to be heard. Tune C4 for a null.

The mixer balance is set by potentiometer R23. Connect signal generator (14.000MHz, USB) to the antenna. Adjust signal for 10dB above noise. Connect spectrum analyzer to connector 76 and adjust R23 to null first LO + signal frequency(59MHz). The output of the mixer, L43, is tuned for maximum on a weak signal.

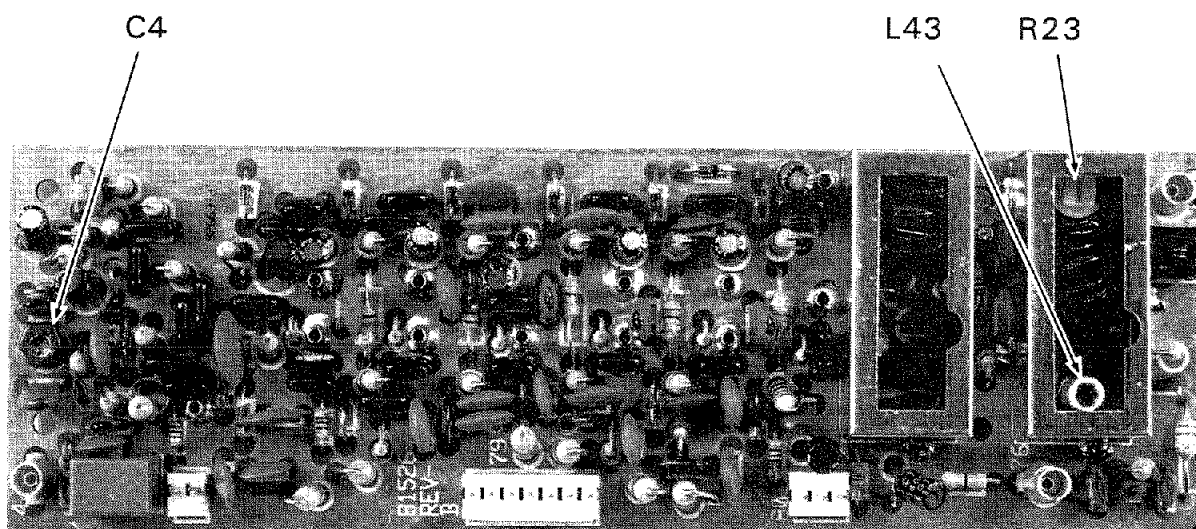
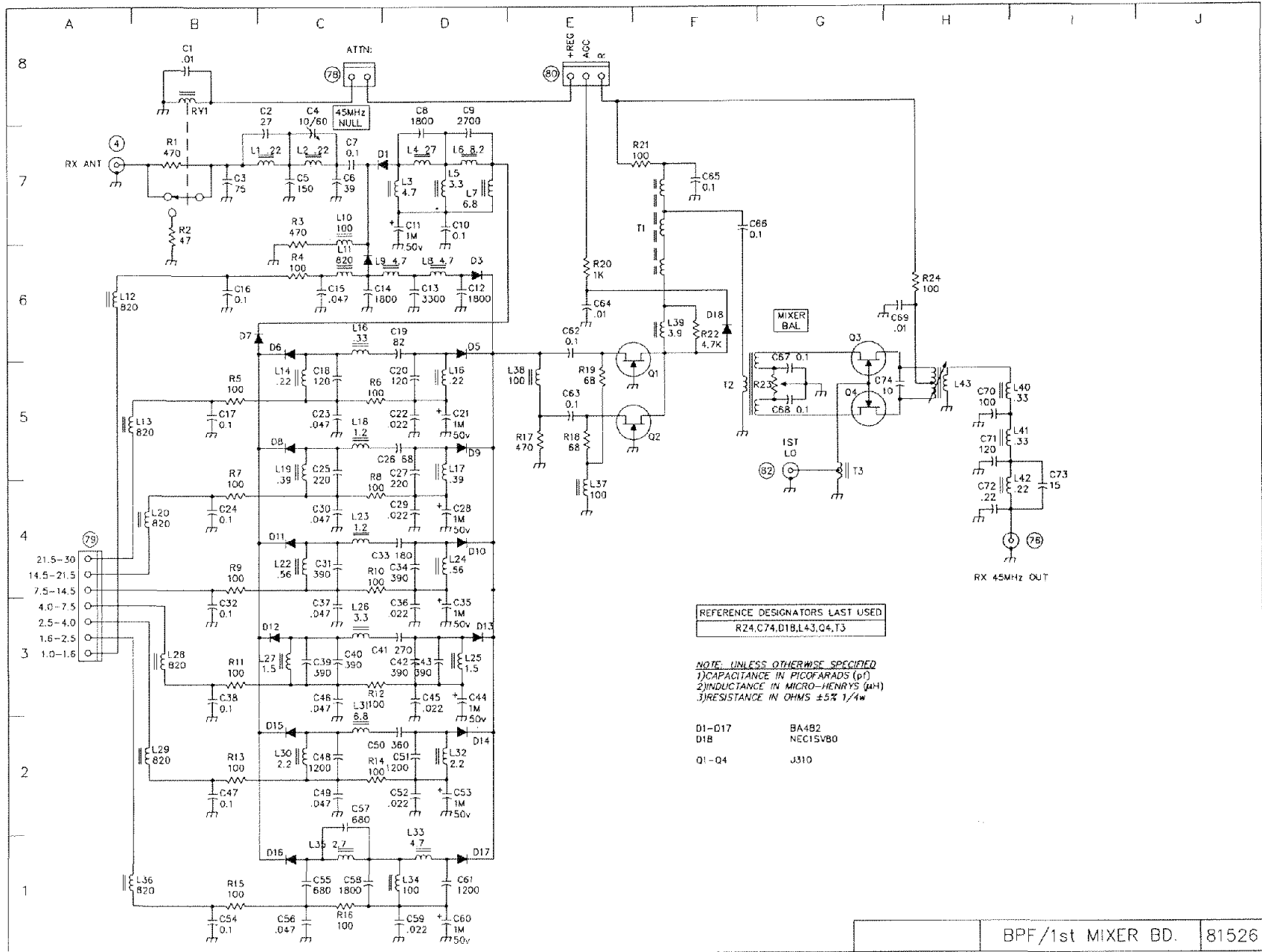

FIGURE 4-33. BAND PASS FILTER / FIRST MIXER COMPONENT LAYOUT (81526)

FIGURE 4-34. BAND PASS FILTER / FIRST MIXER SCHEMATIC (81526)



4-18 RECEIVE SECOND IF BOARD (81527)

This board provides the filtering for the transceiver. It selects between SSB/CW, AM, transmit or receive.

SSB/CW

FL1 and FL2 are 81532 Variable BW filters separated by amplifier Q1. Bandwidth is changed by varying the voltage at the base of Q2 with the front panel BW control (connector 72). In transmit, the filter is set to maximum

bandwidth with the T voltage through diode D7.

AM Filter

FL3 is 81533 AM Filter. Either the SSB/CW filter or the AM filter is selected by diodes D3, D4, D5, D6, D8, and D9 and the voltage at connector 73.

T/R

The receive path or the transmit path is selected by Diodes D1, D2, D10, and D11 and the T and R voltage present at connector 66.

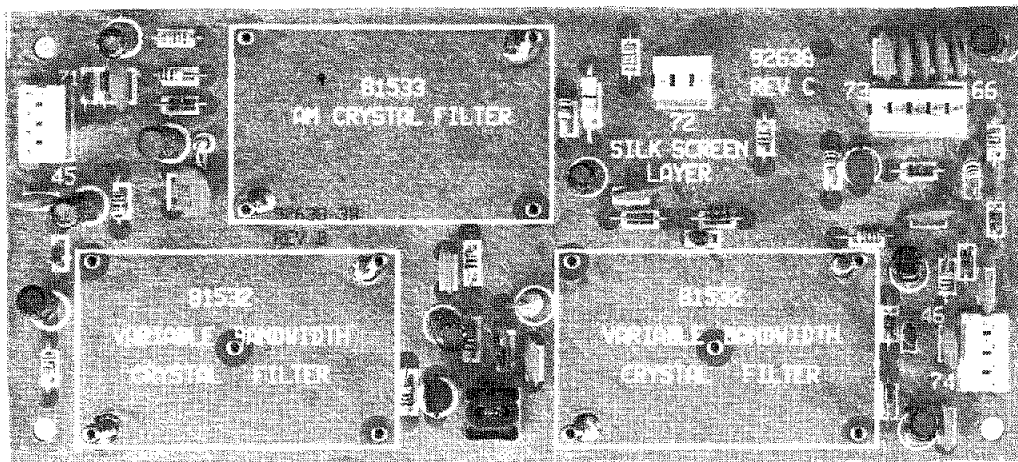
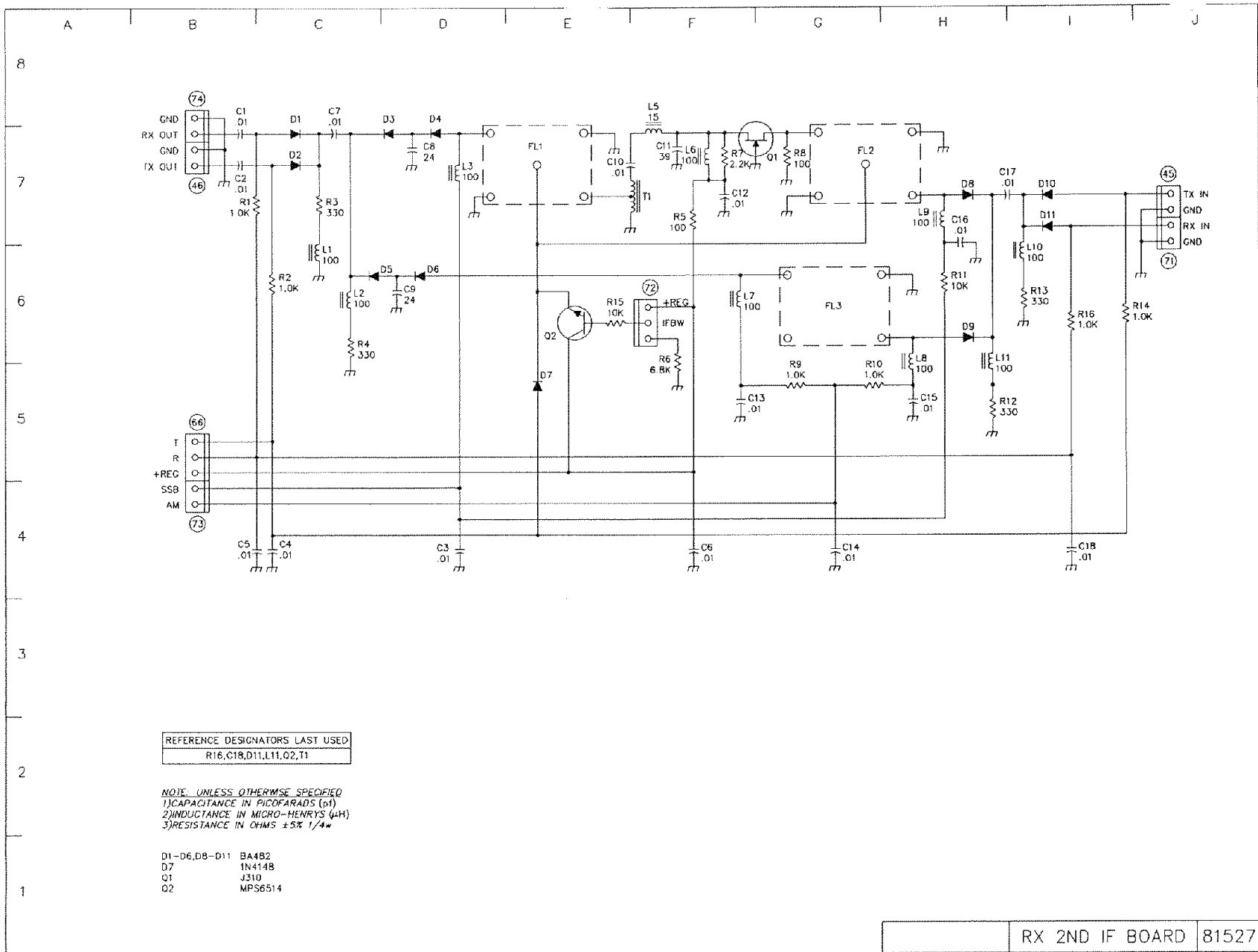

FIGURE 4-35. RECEIVE SECOND IF BOARD COMPONENT LAYOUT (81527)

FIGURE 4-36. RECEIVE SECOND IF BOARD SCHEMATIC (81527)



4-19 FIRST LO BOARD (81528)

This board generates frequencies between 45.1 MHz and 74.99999 MHz in steps of 10 KHz for conversion of the incoming signals to the 45 MHz IF. The use of four oscillators, selected by the microprocessor, reduce microphonics and phase noise. The signal is amplified and available for either receive or transmit circuits.

Each oscillator is a colpitts design using a JFET. A positive voltage from the Logic Board selects the proper VCO (connector A) by turning on Q18, Q17, Q16 or Q15. The output signal is buffered and amplified by Q5, Q6 and Q7. After filtering, the signal is selected by diode D17 or D18 and the voltage at connector 53 for either the receive or transmit circuits. Q9 and Q10 buffer and amplify the output signal before it is applied to the prescaler/PLL circuits. The PLL compares the divided signal with the reference and the phase outputs drive a charge pump (Q11, Q12, Q13, and D14). The charge pump output provides a voltage to the respective varactor (D1, D2, D3, or D4). Information from the micro-

processor sets the correct division of the signal and reference (connector B). Connector C provides the same type of information for the 2nd LO Board.

Alignment

Connect a voltmeter to the emitter of Q14 or the test point TP. Using the frequencies in table 1, adjust coils L1, L2, L3, and L4 for the indicated value. For example, set the transceiver for .10000 MHz, adjust L1 for a voltage between 2.5 to 3.0 volts. Set the transceiver to 7.49999 MHz and check for a voltage between 7.5 and 8.0 volts.

FREQUENCY (TRANSCIVER)	VCO	VOLTAGE
.10000 MHz	1	2.5-3.0
7.49999 MHz	1	7.5-8.0
7.50000 MHz	2	2.5-3.0
14.49999 MHz	2	7.5-8.0
14.50000 MHz	3	2.5-3.0
21.49999 MHz	3	7.5-8.0
21.50000 MHz	4	2.5-3.0
29.99999 MHz	4	7.5-8.0

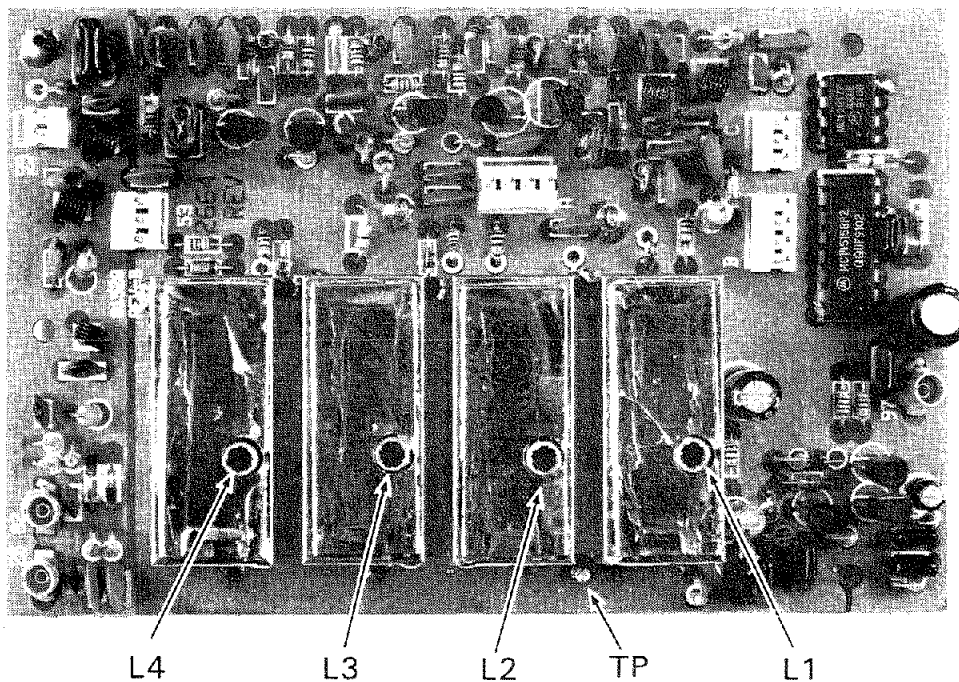
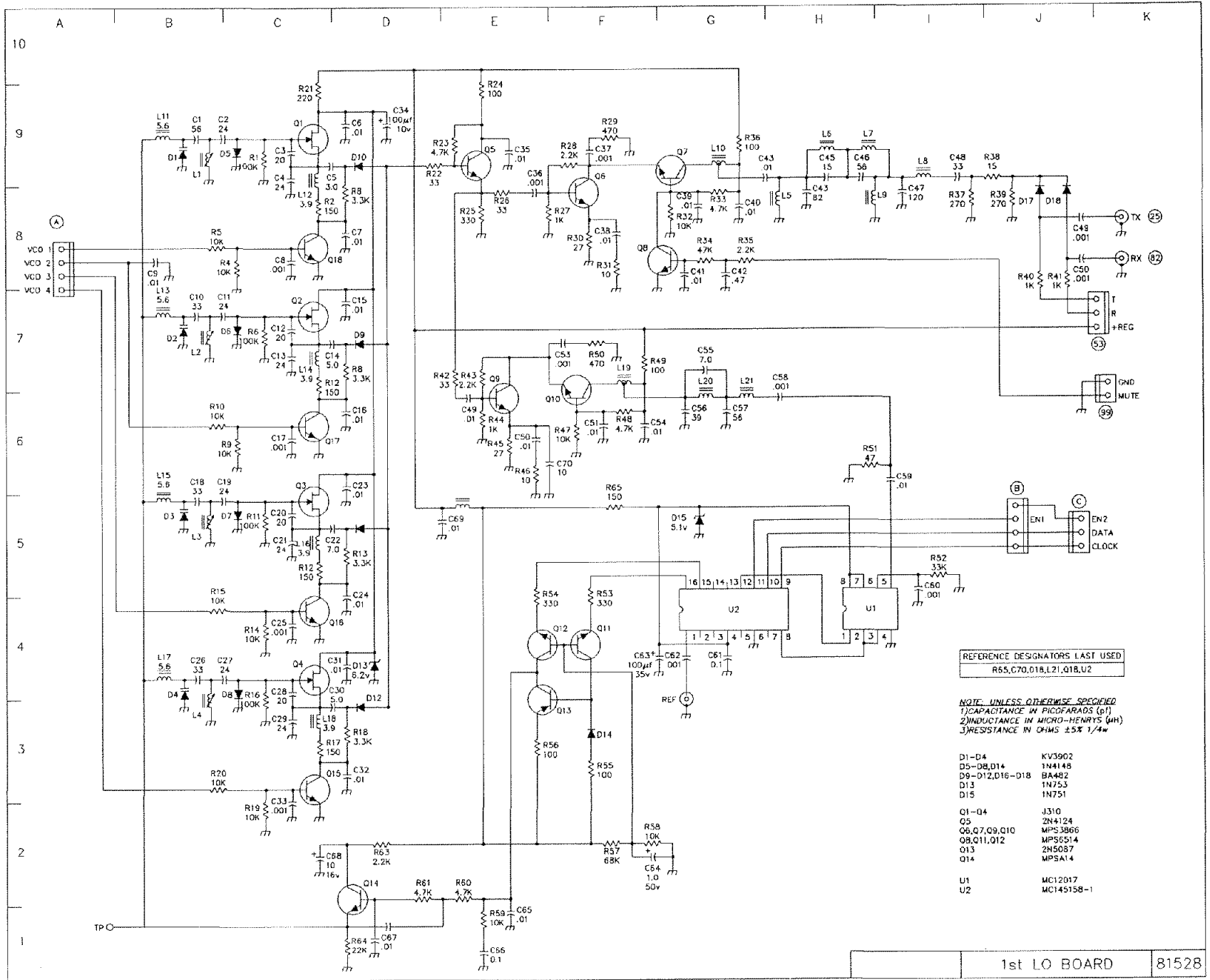

FIGURE 4-37. FIRST LO BOARD COMPONENT LAYOUT (81528)

FIGURE 4-38. FIRST LO BOARD SCHEMATIC (81528)



4-20 SECOND LO BOARD (81529)

The 2nd LO tunes from 38.851 to 38.861 in 10 Hz steps and is used to convert the range of frequencies in the first IF of 45 MHz to 6.144 MHz. The board also contains the master reference oscillator for all PLL units (connectors 94 and 97).

The main VCO, Q1, operating from 73.9 to 74.9 MHz, is buffered by Q2 and Q3. The output of Q2 is divided by 100 in dividers U1 and U2. The resultant 739 to 749 KHz signal is filtered and applied to a mixer (D2, D3, D4, and D5) along with the buffered output of the reference oscillator. The desired output, 10.644 MHz, passes through ceramic filter FL1 and is amplified by Q8. The 9.9 Mhz reference is multiplied by 5 in Q6, filtered by tuned circuits and along with the amplified 10.644 MHz signal, applied to a mixer (D10, D11, D12, and D13). The mixer output is amplified in Q9 and filtered by the tuned circuits. The output is either directed to the receive circuitry by diode D6 or the transmit

circuitry by diode D7. The required voltages, to accomplish the T/R switching, are present at connector 68.

The output of Q3 applies the VCO signal to the PLL U3. The output of the phase detector in U3 controls the VCO frequency by varying the voltage on D1.

Alignment: Connect a VTVM to pin 5 of U3. Set frequency at 15.00500, go to 15.00499 and adjust coil L1 for a reading of 8.0 volts. Connect a spectrum analyzer to the test pin on the board. Adjust L4, L10, L8, and L5 for maximum signal on 49.5 MHz. Output should be approximately 10 dBm. Connect the spectrum analyzer to connector 98 and adjust L9, L6, and L7 for maximum output. Output should be approximately 5 dBm.

Reference: Connect a frequency counter to connector 97. The overall accuracy of the transceiver is controlled by this one crystal oscillator so the accuracy of the frequency counter is very important. Adjust C38 for 9.900000 MHz.

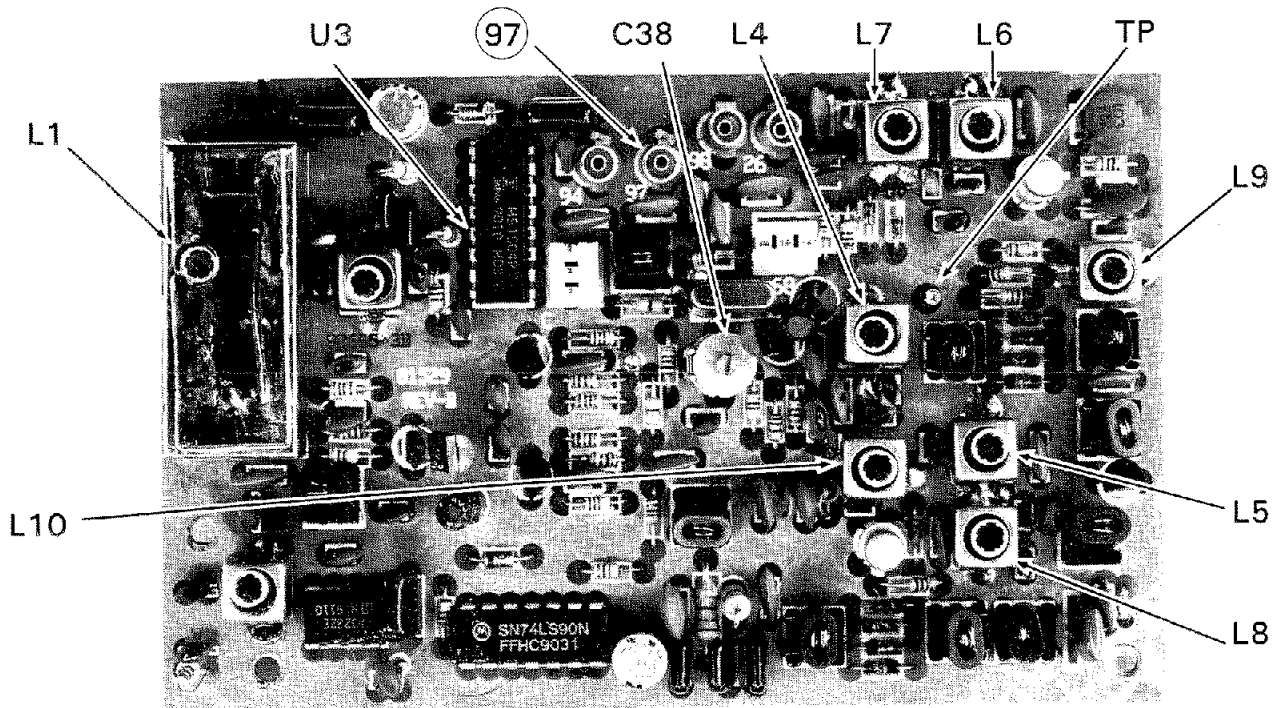
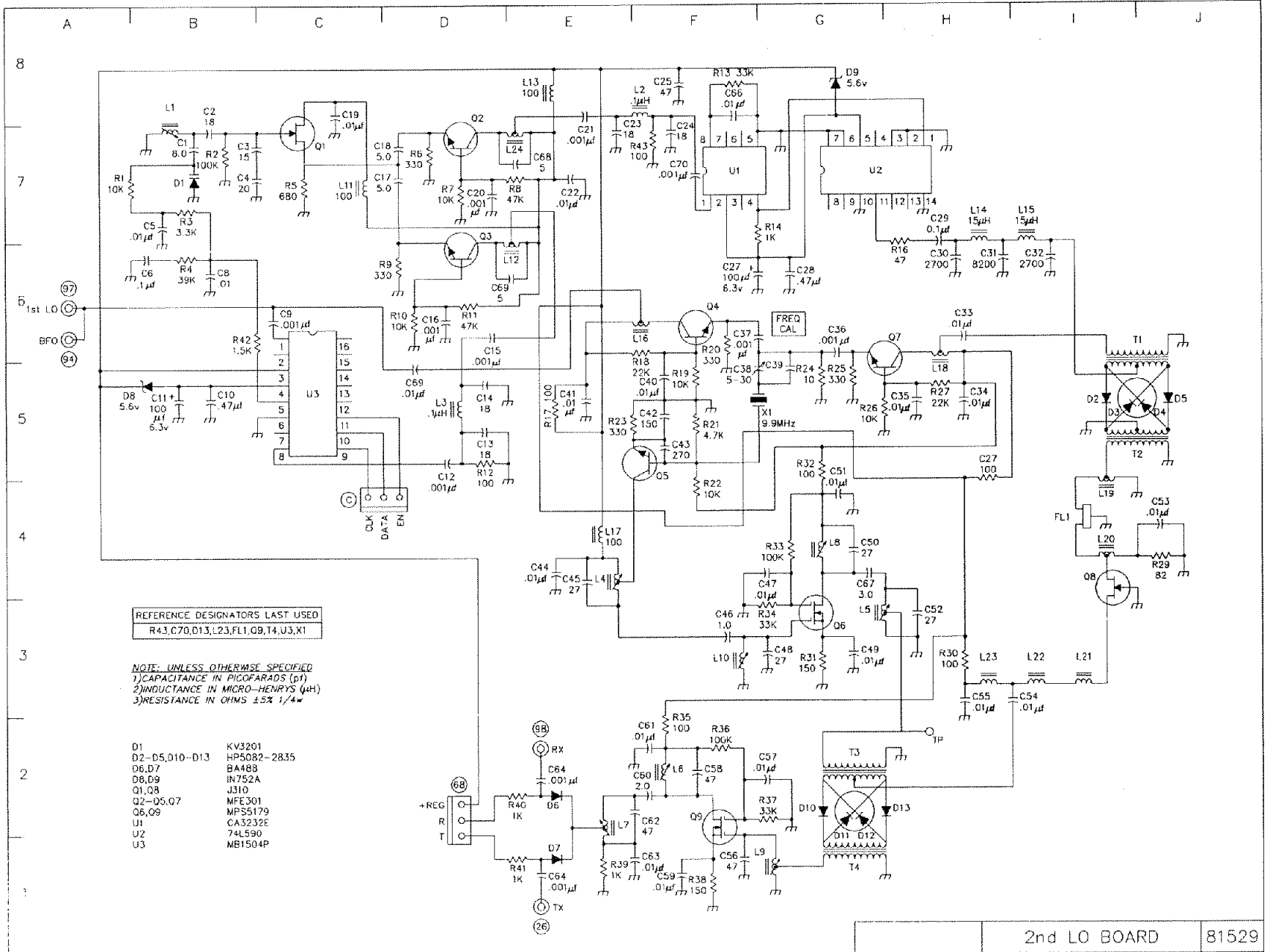

FIGURE 4-39. SECOND LO BOARD COMPONENT LAYOUT (81529)

FIGURE 4-40. SECOND LO BOARD SCHEMATIC (81529)



4-21 BFO BOARD (81530)

The BFO S/A provides signals to be used with the product detector, the balanced modulator, and the FM transmission mode. These signals are all phase locked to the master reference 9.9 MHz oscillator.

BFO/Carrier Oscillator

The VCO, Q1, operates at a frequency of approximately 119 MHz and is phase locked, in steps of 2 KHz, to the master reference of 9.9 MHz. The output is buffered in Q2 and Q3. Q2 drives counter U1 and U2 which divide the oscillator by 100. The reference oscillator (connector 94) is buffered by Q9 and divided by 2 in U2. The divided reference signal and the divided VCO signal are combined in a mixer comprised of D4, D5, D6, and D7. The output is amplified by Q10, filtered and is available at connector 35 and 93 for the product detector and the balanced modulator. The output of Q3 is combined with the output from the FM transmit oscillator (Q7, Q8) and becomes the signal input for PLL U3. The digital information that determines the frequency is applied to U3 via connector 95. The output of the

phase detector drives a charge pump (Q4, Q5, Q6, and D3), loop filter and then the varactor D2.

Alignment: Connect a VTVM to the junction of the collectors of Q4 and Q5. With PBT control centered, adjust L1 for a reading of 4 volts. Connect the VTVM to pin 5 of U3. Select FM mode and place the transceiver in transmit via MIC PTT. Adjust L2 for a reading of 2.5 volts. Return to receive and connect an RF voltmeter to connector 35. Peak L11 and L12 for maximum signal. The output should be approximately -15 dBm.

FM

The FM transmit signal is generated by Q7. The output is combined with the BFO signal and forms the signal reference for PLL U3. The output of the internal charge pump is used, with its loop filter, to lock the oscillator on the transmit frequency determined by the digital information at connector 95. The microphone signal, developed in the TX Audio board, modulates the FM transmit oscillator (connector 43) by varying the voltage on varactor D9.

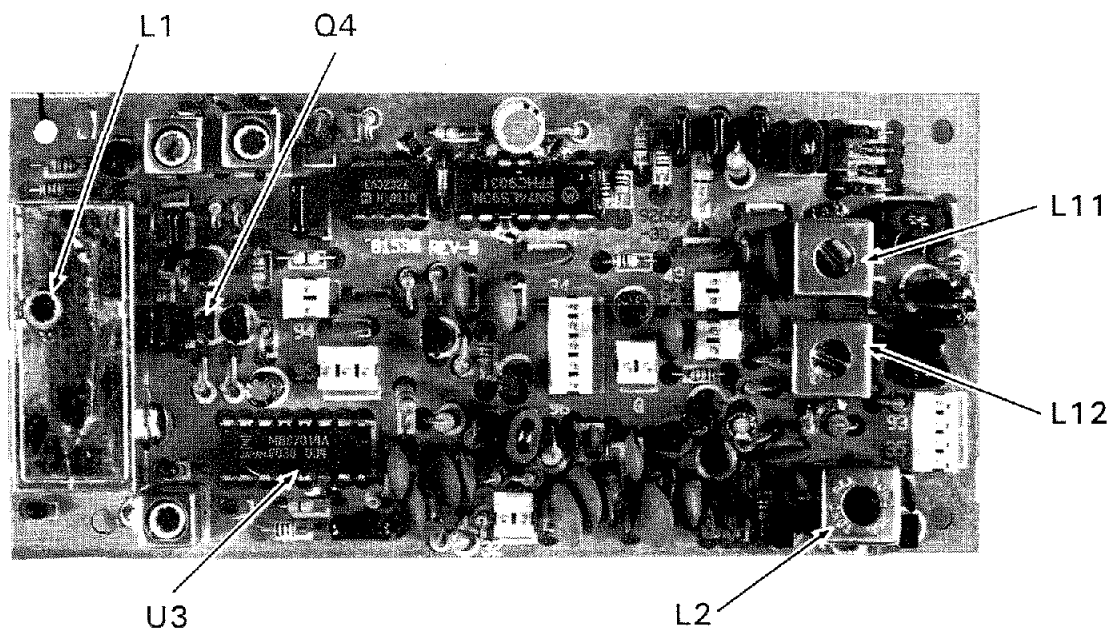

FIGURE 4-41 BFO BOARD COMPONENT LAYOUT (81530)

It shouldn't feel like work.



OMNI-VII. It's that simple.

So sit back in your chair and relax. The Omni-VII not only has top of the line receiver performance and everything else you need in a high-end transceiver -- it's also very easy to use. Spend your time on the air instead of reading the operator's manual. For complete information on the Omni-VII and our Amateur Radio product line, visit our website or call (800) 833-7373 for our current catalog.

Proudly made in Sevierville, Tennessee USA

TEN-TEC
www.tentec.com

1185 Dolly Parton Pkwy., Sevierville, TN 37862. Sales: 800-833-7373 M-F 8:00-5:30 (Eastern Time) sales@tentec.com. Office: (865) 453-7172. FAX: (865) 428-4483. Service: (865) 428-0364 M-F 8:00-5:00 (Eastern Time), service@tentec.com. We accept Visa, MC, American Express and Discover.

FIGURE 4-42. BFO BOARD SCHEMATIC (81530)

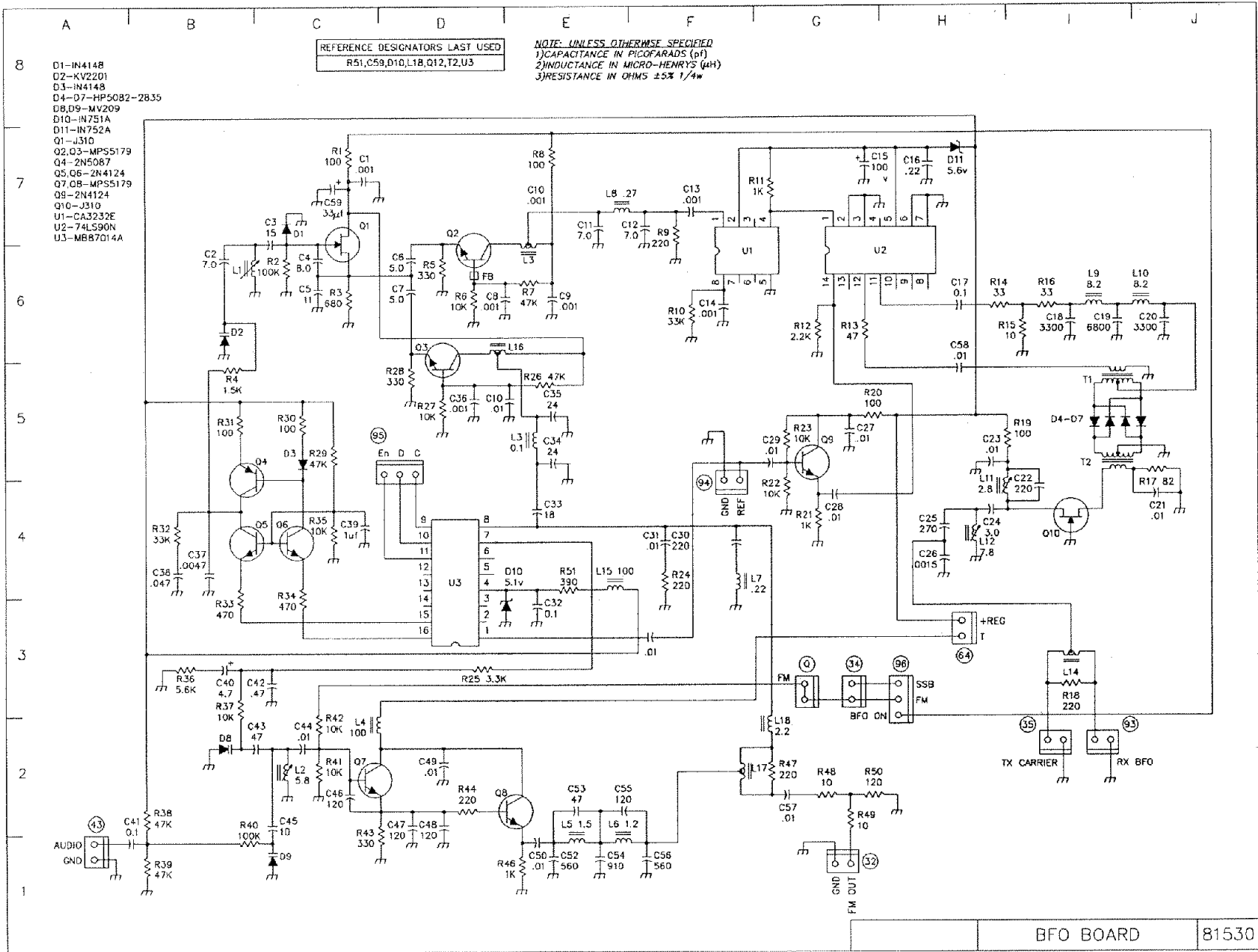

4-22 CONTROL BOARD (81531)

This board contains diode and transistor logic circuitry to develop control voltages based on inputs from the logic board, rear panel control jacks, or front panel switches, that determine the mode of operation (SSB, CW, transmit, receive, etc.) of the various circuits in the transceiver. It also contains the CW wave shaping circuit that sets the rise and fall times of the transmitted CW envelope, and the hold-in adjustment for the auxiliary T/R switch.

A request to transmit is sent by grounding the VOX/PTT line, or grounding the KEY line or from the TUNE button. The voltage at the collector of Q5 is used to either mute the audio amplifier, via connector 50, or sent to the logic board via connector 62 to let the microprocessor know that there has been a request to transmit. When the logic board receives the transmit request, it checks the frequency registers to determine if there should be a change before transmitting, such as would be required if in split etc. It then determines how much time is required to allow all frequencies to become stabilized and then sends an acknowledge signal back to the control board via connector 62. The acknowledge signal keys transistor Q8 which then starts the transmit voltages by enabling transistor Q20 through connector 55. Connector 55 may be used to send and receive a ready signal to and from a device such as a linear to prevent "hot switching" the linear.

Transistors Q17 and Q18 form an integrator that provides the keying wave form for CW and develops the required transmit ("T") and receive ("R") voltages to run the circuits in the transceiver.

T/R SWITCH

An external transmit/receive switch via J-1, that may be used on both SSB or CW, can be connected to the T/R SWITCH via connector 60. This will enable transistor Q22 to send a signal to the mute pin on the audio amplifier, and activate the linear switch Q23. The transceiver may then be keyed for CW or the mic PTT used for SSB.

LINEAR DELAY

When in the CW mode, transistor Q21 grounds capacitor C8 to provide a turn-off delay to the LINEAR pin of connector 60. The delay time may be set with potentiometer R36.

REGULATOR

Transistors Q1, Q2, Q3, and Q4 provide a regulated voltage that is used on all the low level circuits in the transceiver. Cables 52,67,30,65,6,54,63,50, and 15 distribute T, R, +REG, and +13.5 Volts to the circuit boards. Wires in these cables are color coded as follows: T - blue, R - yellow, +REG - orange, +13.5 - red.

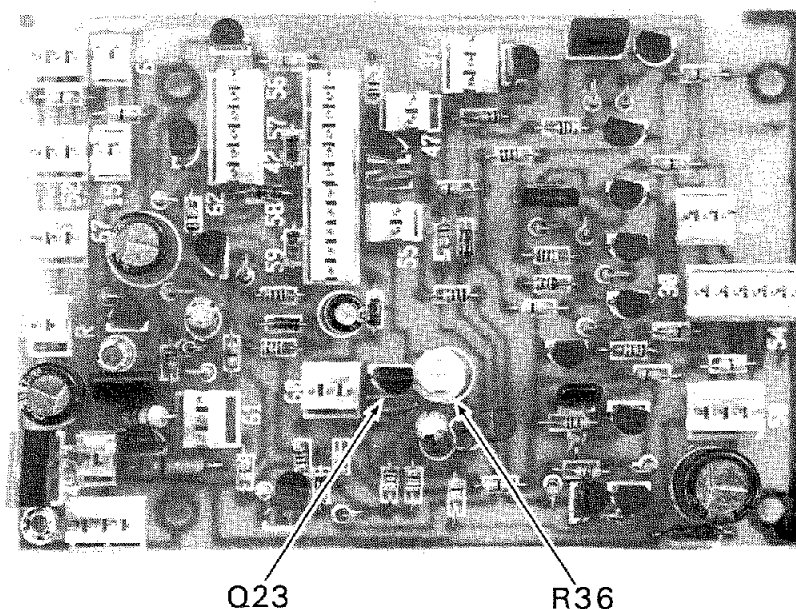
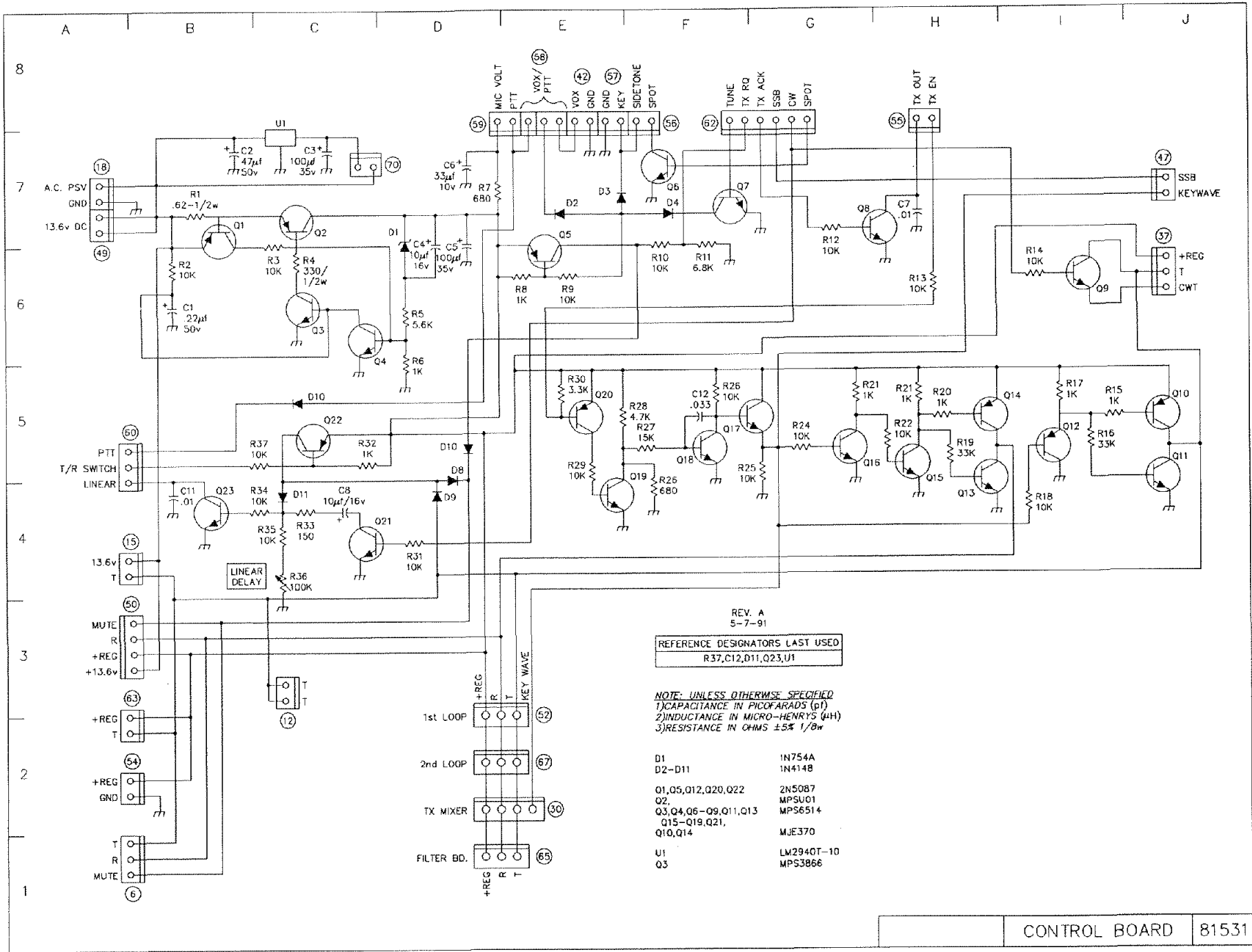

FIGURE 4-43. CONTROL BOARD COMPONENT LAYOUT (81531)

FIGURE 4-44. CONTROL BOARD SCHEMATIC (81531)



4-23 VARIABLE BANDWIDTH CRYSTAL FILTER (81532)

In CW and SSB modes, the receiver selectivity is established by the Variable Bandwidth Crystal Filters located on the RX/2nd IF board 81527. Each variable bandwidth filter unit is a varactor tuned 4-pole ladder type filter. Two of these units are connected in cascade with an amplifier in between (Q1 on the RX/2nd IF board) to provide 8 poles of variable bandwidth selectivity. The receiver selectivity is continuously variable from 500 to 2500 Hz bandwidth (-6dB) with a constant 8-pole response.

Refer to figure 4-11; Variable Bandwidth Filter schematic diagram. All the crystals and varactor diodes in the variable bandwidth filter are identical. C1, C2, D1 and L1 form a variable impedance matching network which transforms the natural impedance of the filter end section to 50 Ohms for all bandwidths. C3, C4, D5 and L2 perform the same function at the other end of the filter. Varactor diodes D2,

D3, and D4 form the shunt capacitors of the ladder network. Factory set potentiometers R1 through R5 select the proper portion of the bandwidth control voltage for each varactor diode and compensate for small parts tolerances and manufacturing variations. The settings of R1 through R5 are critical to the proper operation of the variable bandwidth filter and should not be altered without the aid of an accurate network analyzer. As the Bandwidth Control voltage is varied by the front panel IF BW control, the filter parameters vary from 500 Hz bandwidth and 126 ohm natural impedance at 2 volts, to 2500 Hz bandwidth and 760 ohm natural impedance at 10 volts. The variable end matching networks "track out" the impedance variation producing a continuously variable bandwidth and constant 50 Ohm termination impedance. In transmit mode, D7 on the RX/2nd IF board pulls the Bandwidth Control line high to set the filter to 2500 Hz bandwidth regardless of the setting of the IF BW control.

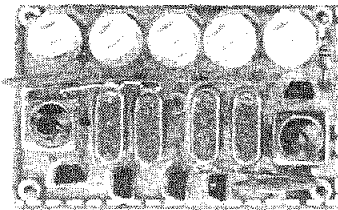

FIGURE 4-45.
VARIABLE BANDWIDTH CRYSTAL FILTER COMPONENT LAYOUT
(81532)

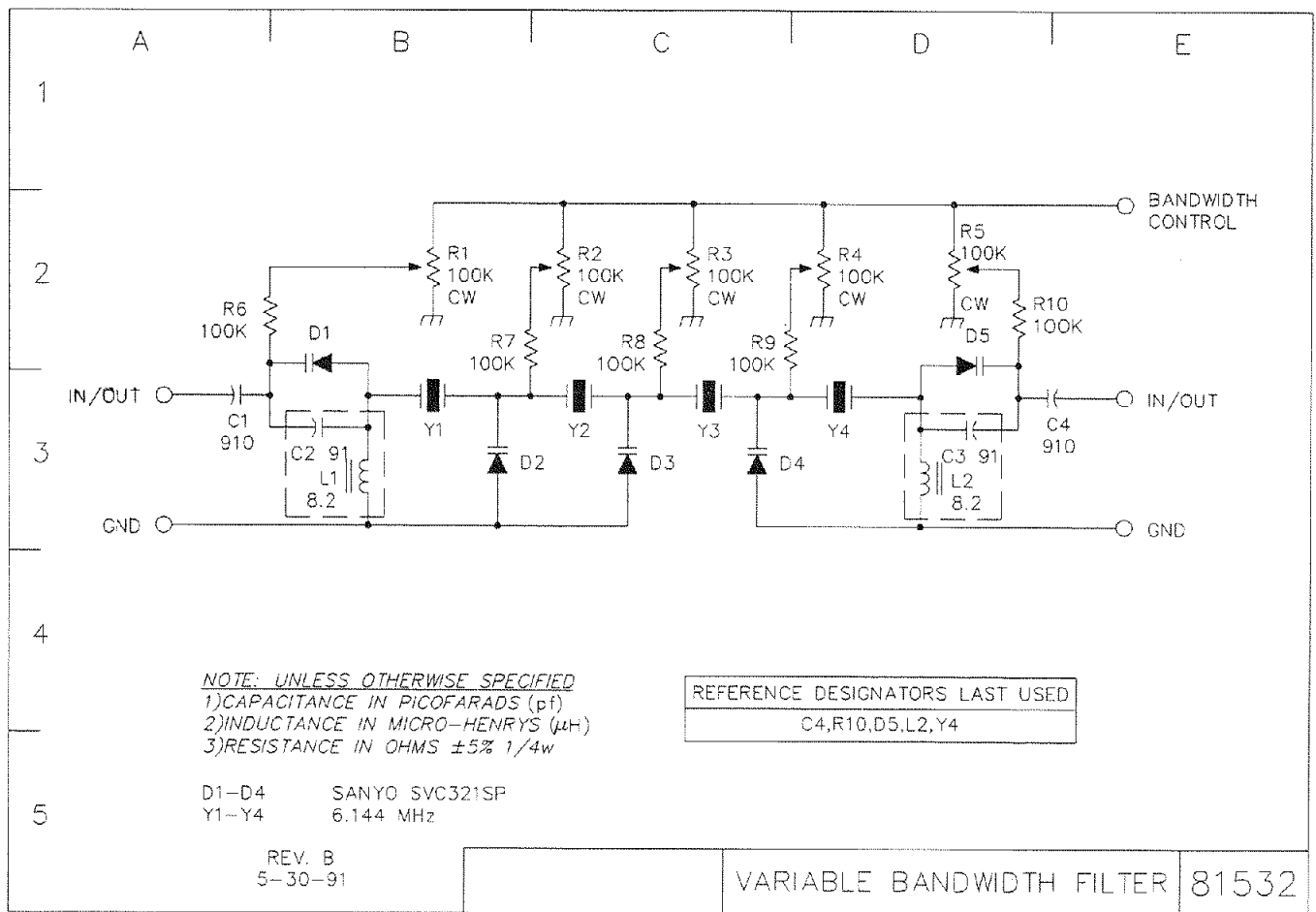

FIGURE 4-46.
VARIABLE BANDWIDTH CRYSTAL FILTER SCHEMATIC (81532)

4-24 AM CRYSTAL FILTER BOARD (81533)

In AM mode, the receiver selectivity is established by the AM Crystal Filter located on the RX/2nd IF board 81527. This filter is a 5 KHz bandwidth, five-pole ladder type. Refer to figure 4-12; AM Crystal Filter schematic. C1-L1 and C8-L2 match the natural impedance of the ladder network end sections to 50 Ohms. Since the end section impedance of this filter is relatively high (about 1400 Ohms), the T1-C2 and T2-C7 networks are used to cancel the 3pF holder capacitance of the end section xtals. This improves the symmetry of the filter response by increasing the attenuation slope in the lower stopband.

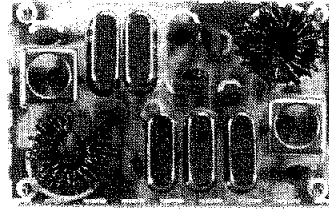

FIGURE 4-47. AM FILTER BOARD COMPONENT LAYOUT (81533)

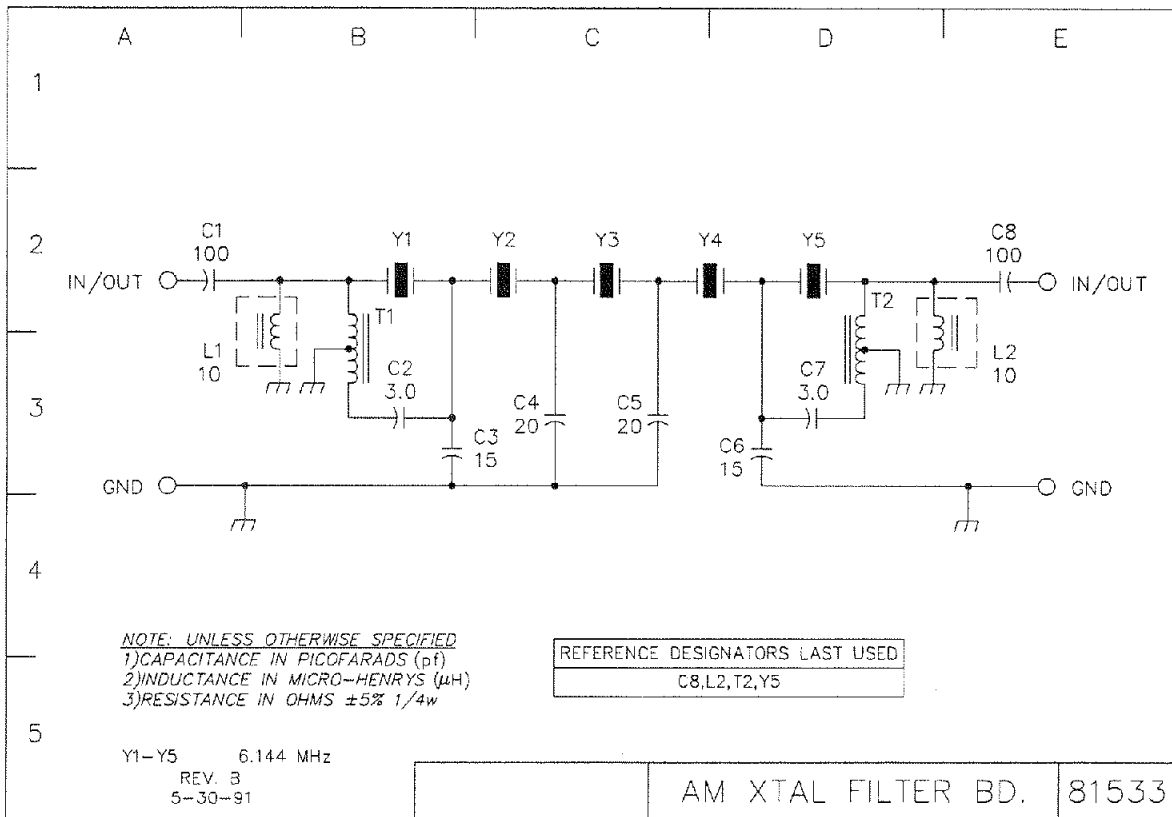

FIGURE 4-48. AM FILTER BOARD SCHEMATIC (81533)

4-25 NOISE BLANKER/FM BOARD (81544)

This board contains the noise blanker and the receive portion of the FM mode. At connector 75, a sample of the 6.144 MHz receive signal from the 2nd mixer board is input to noise blanker amplifiers U2 and U3. Part of the output of U2 is sent to the FM receive circuit. The output of U3 drives the AGC circuit (Q5, Q6) and the noise blanker pulse circuit (Q2, Q3, Q4). In the AGC circuit, Q6 is a peak detector developing a DC voltage proportional to the signal and noise at its input. The AGC attack time is controlled by the time constant comprised of R21, R19, R20, and C15. This is set so the sharp noise pulses will not activate the AGC, only a slowly varying signal such as SSB or CW will cause the AGC to reduce the gain in the noise blanker IF. This AGC action helps to keep the noise pulse large compared to the signals and makes it much easier for pulse peak detector Q2 to develop a pulse for blanking. Capacitor C14 sets the pulse width. The noise blanker pulse is fed to the noise blanker gate, located on the 2nd mixer, by way of connector 77.

The FM receive function is performed by U1. A portion of the 6.144 MHz signal from U2 is applied to the input of U1. The mixer portion of U1 converts the signal to 455 kHz

where it is processed by the proper FM filter, CF1, amplified, limited and detected by a quadrature detector. Integrated circuit U1 also provides a squelch that is activated by a voltage applied to connector E. The FM mode is activated by the logic board and sends a voltage to the FM board via connector Q. The voltage also is sent to the TX Audio board via connector D to be used in the transmit pre-emphasis. The recovered FM audio from connector 92 is sent to the IF audio board.

Alignment: Connect a variable noise source to the input of the receiver and an oscilloscope to the collector of the pulse generator, Q4. Reduce the amplitude of the noise source until the pulse is about to disappear. Tune L2 and L1 for maximum pulse width. reduce the amplitude of the noise source as required.

Connect a signal generator to the input of the receiver. Set the FM modulation on the generator to 5 KHz deviation. Make certain the receiver is set to the frequency of the generator and tune T2 for minimum distortion on the signal.

R7 is used to set the squelch threshold. Terminate the antenna with a 50W load. Place unit in FM mode. Adjust R7 until receiver audio is no longer heard.

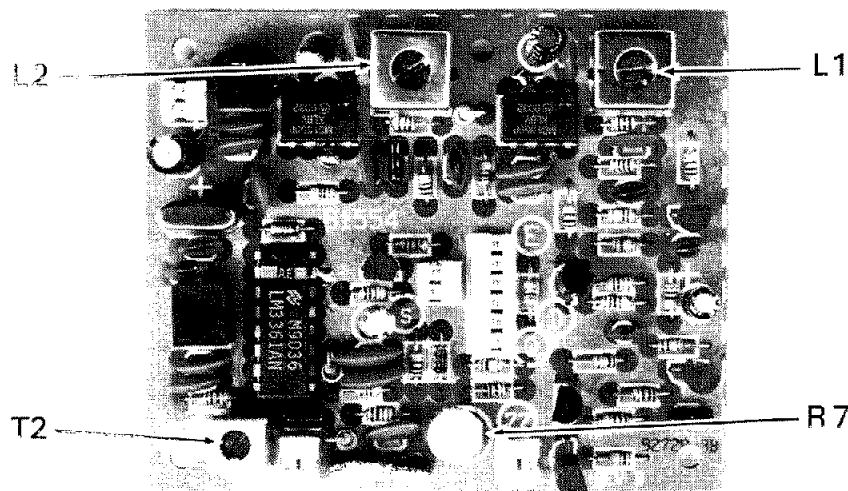
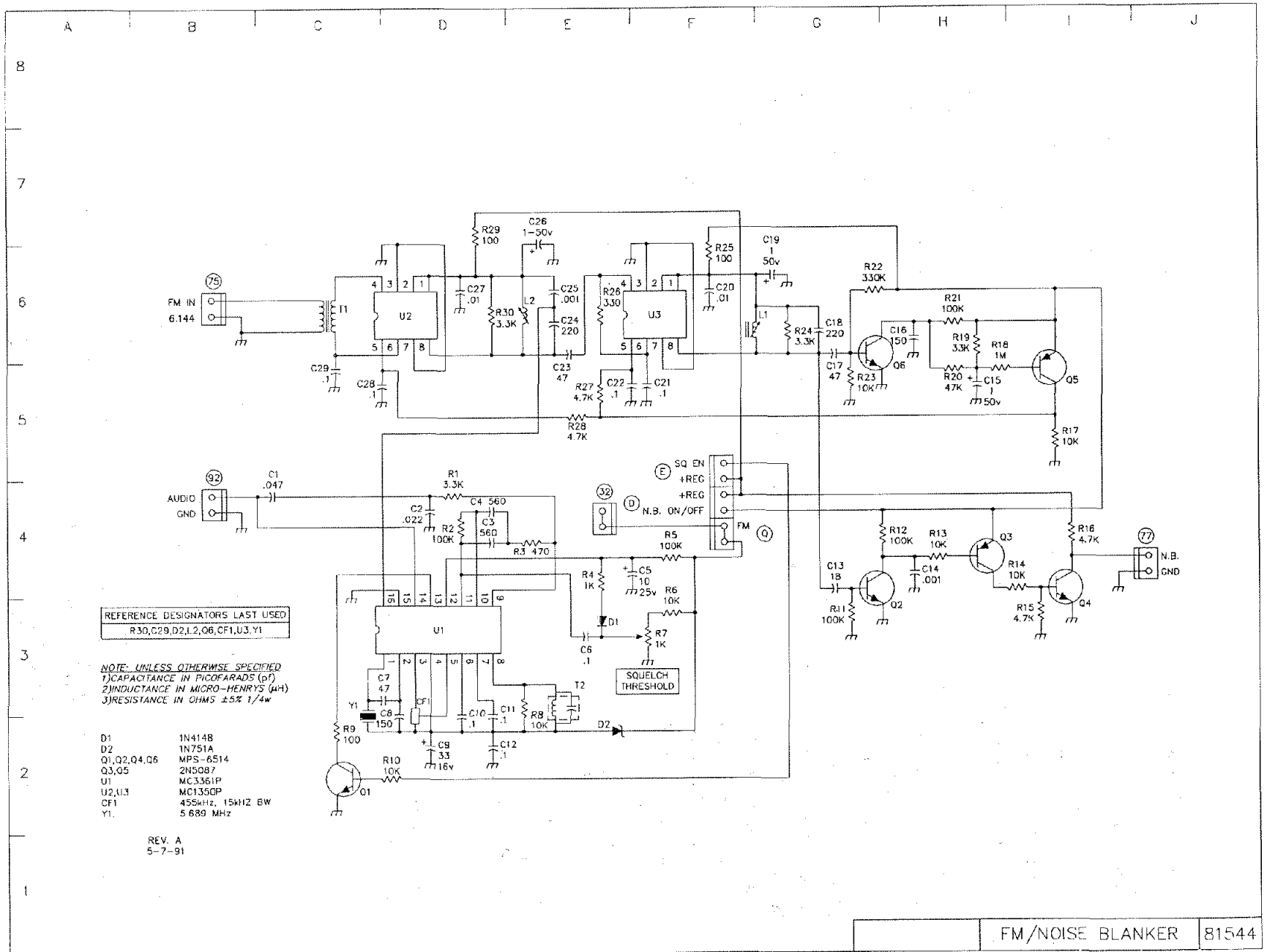
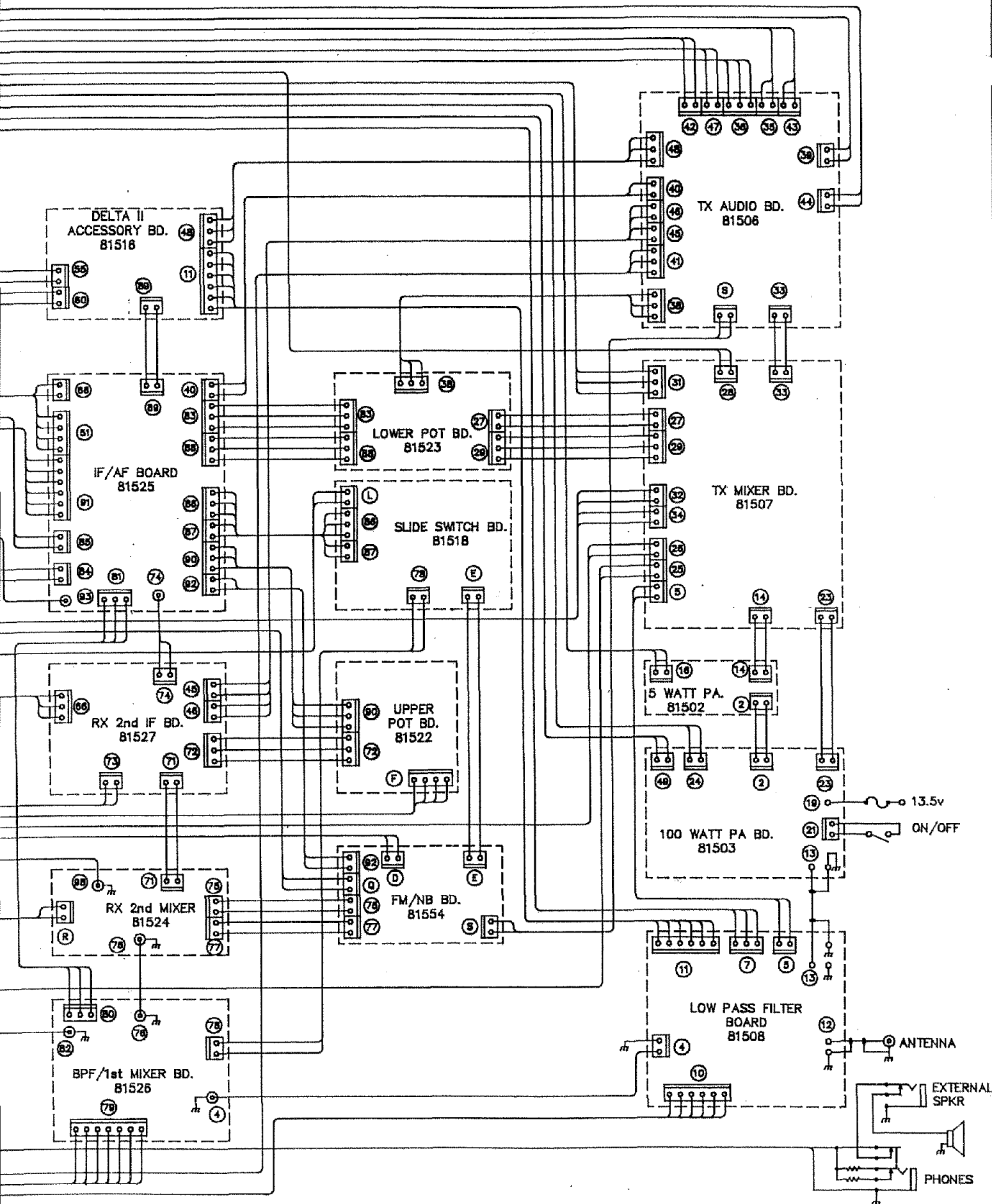

FIGURE 4-49.
NOISE BLANKER/FM BOARD BOARD COMPONENT LAYOUT (81544)

FIGURE 4-50.
NOISE BLANKER/FM BOARD SCHEMATIC (81544)







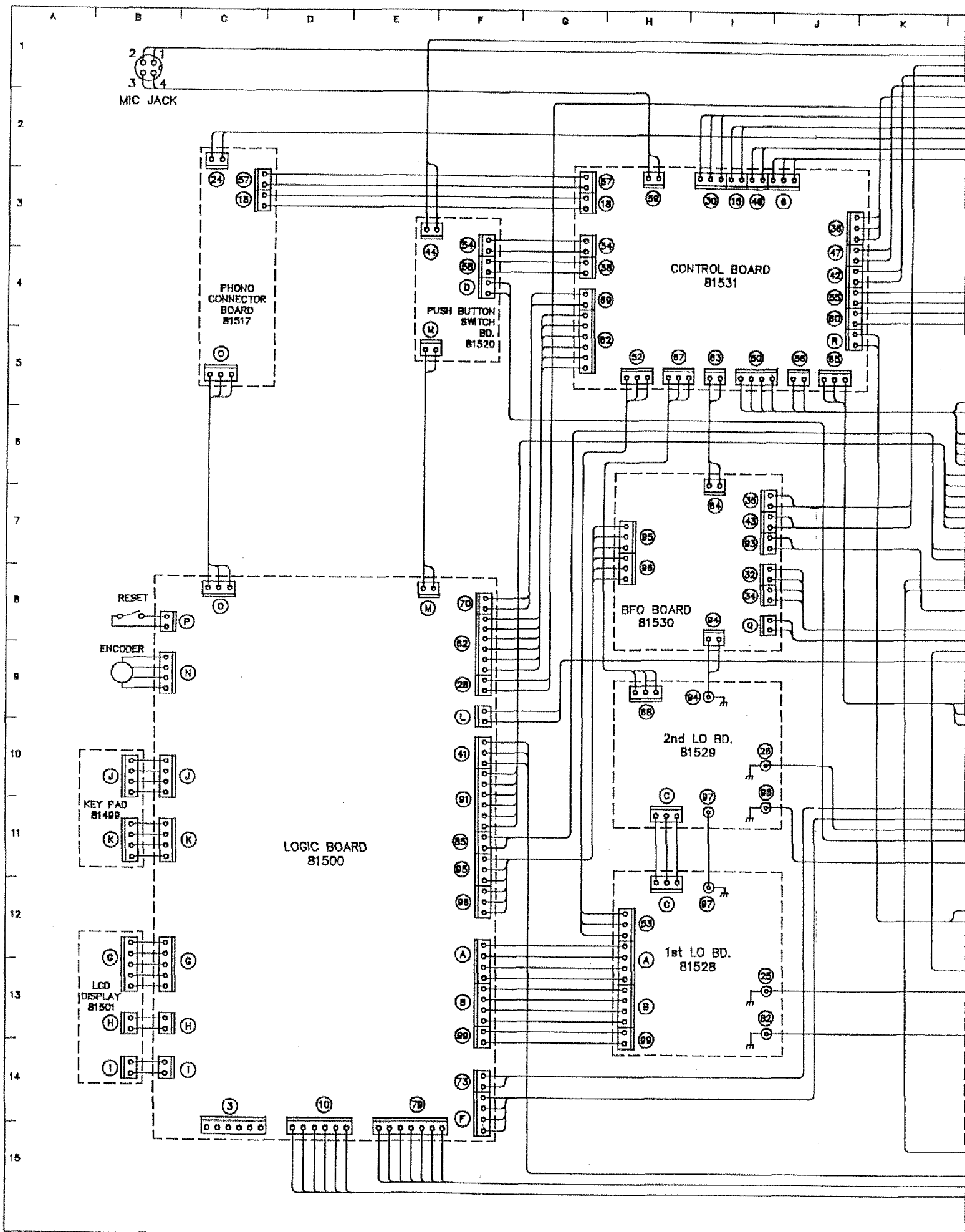



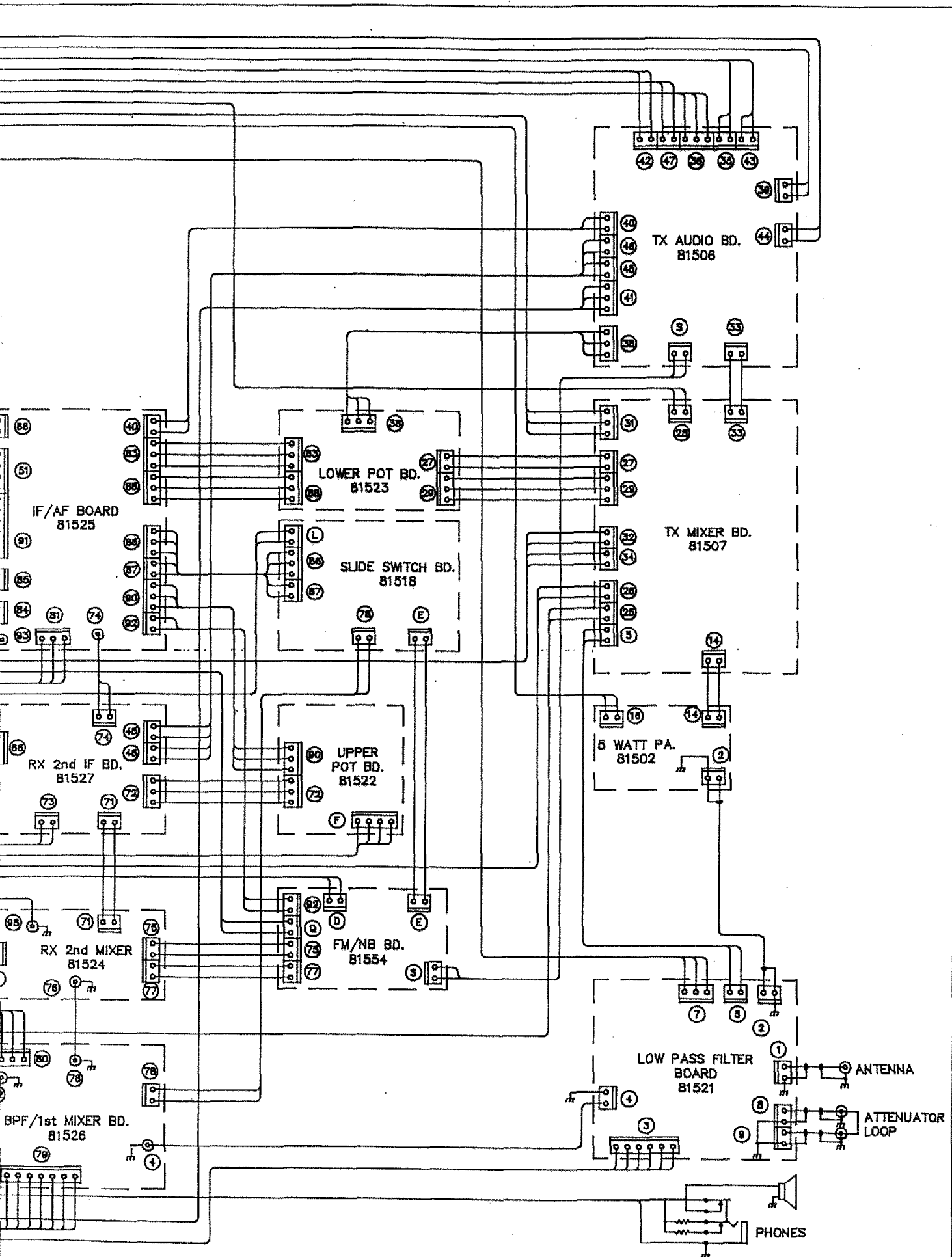



A B C D E F G H I J

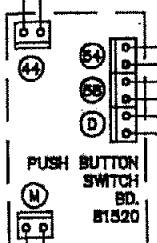
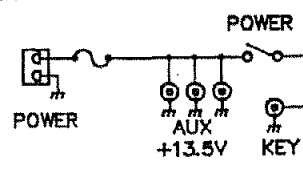

CONTROL BOARD 81531

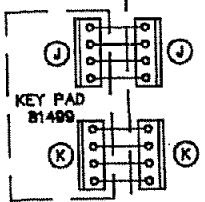
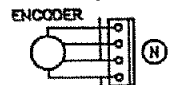
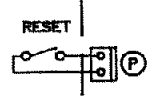
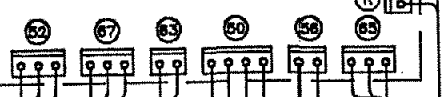

LOGIC BOARD 81500

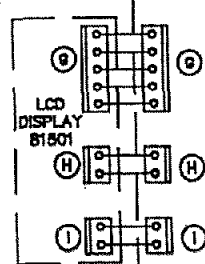

BFO BOARD 81530

2nd LO BD. 81529

1st LO BD. 81528

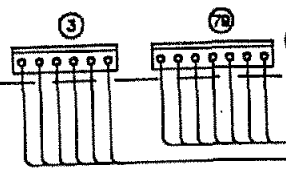

8
7
6
5
4
3
2
1

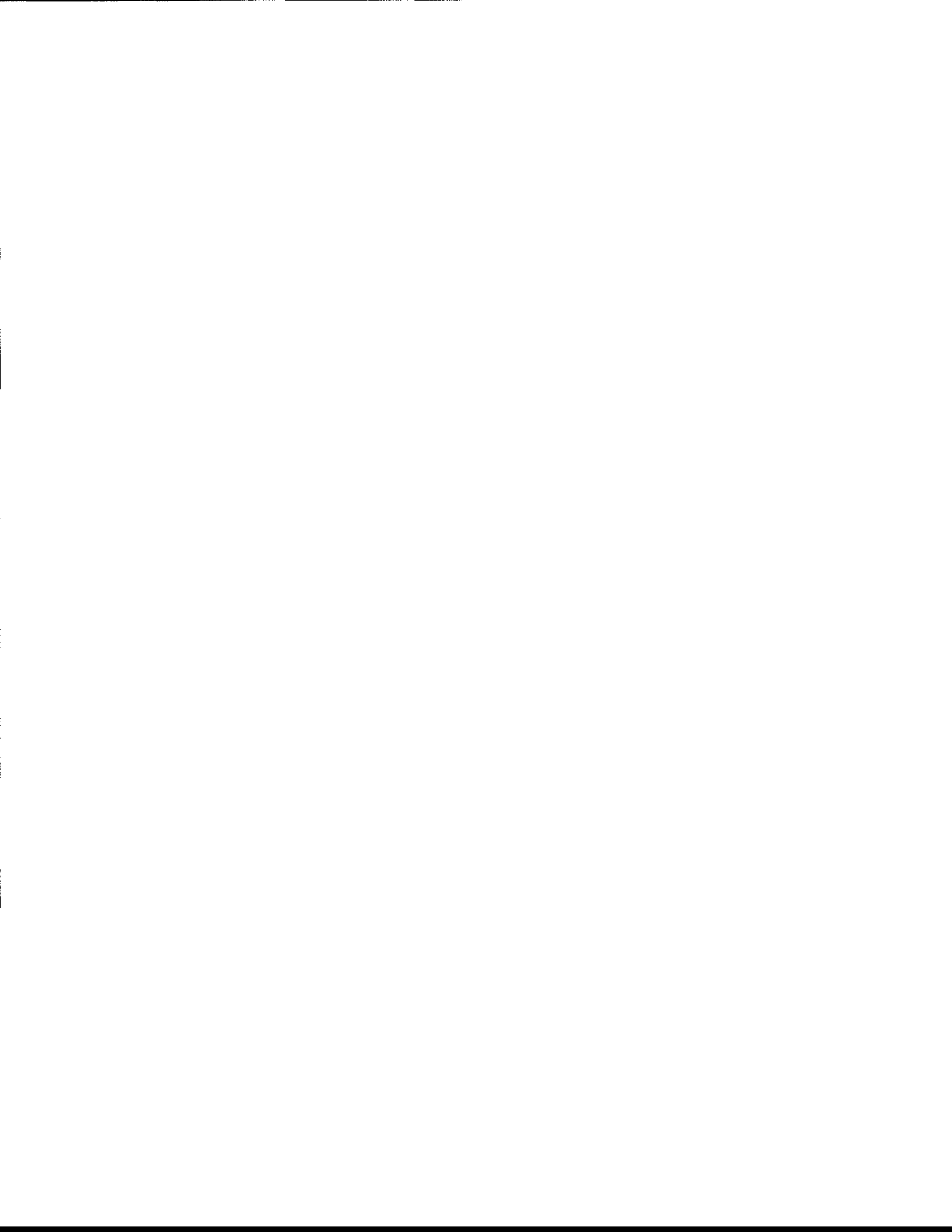

Ten-Tec, Inc.
1185 Dolly Parton Parkway
Sevierville, TN 37862
Repair Service: (865) 428-0364

LIMITED WARRANTY AND SERVICE POLICY, U.S.A. AND CANADA

Ten-Tec, Inc., warrants this product to be free from defects in material and workmanship for a period of one (1) year from the date of purchase, under these conditions:

1. THIS WARRANTY APPLIES ONLY TO THE ORIGINAL OWNER. It is important that the warranty registration card be sent to us promptly.
2. READ THE MANUAL THOROUGHLY. This warranty does not cover damage resulting from improper operation. Developing a thorough understanding of this equipment is your responsibility.
3. IF TROUBLE DEVELOPS we recommend you contact our customer service group direct at the address or phone number shown above. It has been our experience that factory direct service is expeditious and usually results in less down-time on the equipment. Some overseas dealers do offer warranty service and, of course, have our complete support.
4. EQUIPMENT RETURNED TO THE FACTORY must be properly packaged, preferably in the original shipping carton(s). You pay the freight to us and we prepay surface freight back to you. Canadian customers must have proper customs documentation sent with incoming repair equipment. Duties or fees charged due to improper documenting are the responsibility of the owner of the equipment.
5. EXCLUSIONS. This warranty does not cover damage resulting from misuse, lightning, excess voltages, polarity errors or damage resulting from modifications not recommended or approved by Ten-Tec. In the event of transportation damage, a claim must be filed with the carrier. Under no circumstances is Ten-Tec liable for consequential damages to persons or property caused by the use of this equipment.
6. TEN-TEC RESERVES the right to make design changes without any obligation to modify equipment previously manufactured, or to notify owners of changes to existing equipment.
7. THIS WARRANTY is given in lieu of any other warranty, expressed or implied.

SERVICE OUTSIDE OF THE U.S.A. OR CANADA

Many of our international dealers provide warranty service on the equipment they sell. Many of them also provide out of warranty service on all equipment whether they sold it or not. If your dealer does not provide service or is not conveniently located, follow the procedure outlined above. Equipment returned to us will be given the same attention as domestic customers but roundtrip freight expense, customs and broker fees will be paid by you.

Part no. 74244

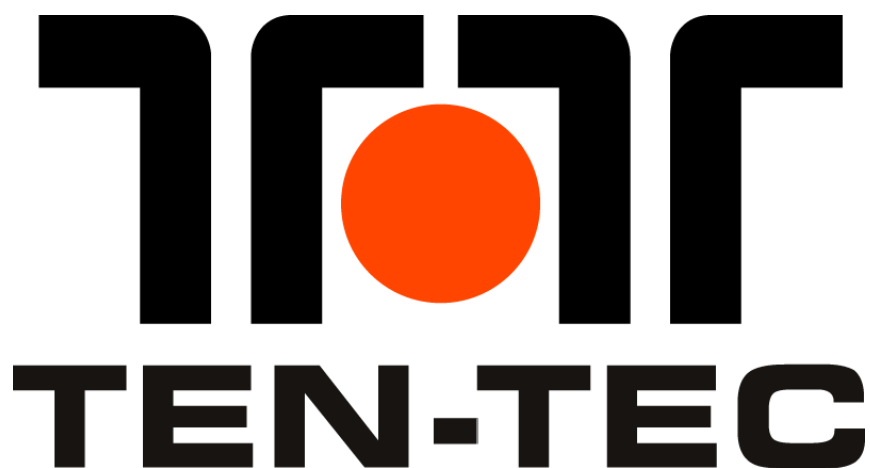

This obsolete manual file is provided as a courtesy to you by Ten-Tec, Inc.

Ten-Tec's service department can repair and service virtually everything we have built going back to our first transceivers in the late 1960's. It is our ability to continue offering service on these rigs that has led to their re-sale value remaining high and has made a major contribution to our legendary service reputation.

Printed and bound copies of all manuals are available for purchase through our service department if you would prefer not to use this copy as your transceiver manual.

We can repair or service your Ten-Tec equipment at our facility in Sevierville, TN. We also offer support via telephone for all products via during usual business hours of 8 a.m. to 5 p.m. USA Eastern time, Monday through Friday. We have a large supply of parts for obsolete products. Repairing a transceiver or amplifier yourself? Contact us for parts pricing information.

**Service department direct line: (865) 428-0364
Ten-Tec office line: (865) 453-7172
Service department email: service@tentec.com
Address: 1185 Dolly Parton Parkway, Sevierville, TN 37862 USA**

We have found it is most effective for us to help you troubleshoot or repair equipment with a consultation via telephone rather than by email.

Suggested contact methods are:

**Troubleshooting or repairing equipment – call (865) 428-0364
Other inquiries – call (865) 428-0364 or email service@tentec.com**

THANK YOU AND 73 FROM ALL OF US AT TEN-TEC