

ICF-SW1

AN-101

SERVICE MANUAL

SCHEMATHEEK
Beh. T. Hultermans
Postbus 4228
5604 EE Eindhoven



US Model
Canadian Model
AEP Model
UK Model
E Model
Austrarian Model

SPECIFICATIONS

Circuit system	FM: Superheterodyne AM: Dual, conversion superheterodyne	Weight	Approx. 230 g (5 lb 6.5 oz) including batteries
Frequency range	FM: 76 – 108 MHz (TYPE 1) 87.5 – 108 MHz (TYPE 2 to 4) LW: 150 – 528 kHz (TYPE 1 to 3) 150 – 285 kHz (TYPE 4) MW: 531 – 1,611 kHz (at MW channel step selector set to 9 kHz) 530 – 1,610 kHz (at MW channel step selector set to 10 kHz) SW: 1,615 – 29,995 kHz (TYPE 1, 3) 1,615 – 26,100 kHz (TYPE 2, 4)	Accessories supplied	AC power adaptor (1, except for Australian model) Stereo earphones (1) Antenna controller (1) Antenna module (1) Carrying case (soft ... 1 hard ... 1) AC plug adaptor (1, except for UK model) Suction cup (1) Carrying belt (1)
Antennas	Telescopic antenna (FM/SW) Built-in ferrite bar antenna (MW/LW) Active antenna (LW/MW/SW)	Optional accessories	
Speaker	Approx. 66 x 35 mm (2 ⁵ / ₈ inches x 1 ¹ / ₂ inches) 8 ohms	Car battery cord	DCC-127A, DCC-240
Power output	250 mW (at 10% harmonic distortion)	Connecting cord	RK-135A (miniplug to stereo miniplug)
Outputs	Recording output jack (minijack) output level 0.775 mV (–60 dB) output impedance 1 kilohm Headphone jack (stereo minijack) for 18 ohm stereo earphones		
Power requirements	Radio: 3 V dc Two size AA (R6) batteries Supplied AC power adaptor (110, 120, 220 or 240 V ac adjustable, 50/60 Hz) Optional DCC-127A car battery cord for use with 12 V car battery		
Battery life	Radio: approx. 12 hours of listening for four hours a day at a normal volume, using Sony SUM-3 (NS) batteries		
Dimensions	Approx. 118.2 x 71.4 x 23.7 mm (w/h/d) (4 ³ / ₄ x 2 ⁷ / ₈ x 1 ⁵ / ₁₆ inches) including projecting parts and controls		

SAFETY-RELATED COMPONENT WARNING!!

COMPONENTS IDENTIFIED BY MARK  ON THE SCHEMATIC DIAGRAMS AND IN THE PARTS LIST ARE CRITICAL TO SAFE OPERATION. REPLACE THESE COMPONENTS WITH SONY PARTS WHOSE PART NUMBERS APPEAR AS SHOWN IN THIS MANUAL OR IN SUPPLEMENTS PUBLISHED BY SONY.

ATTENTION AU COMPOSANT AYANT RAPPORT À LA SÉCURITÉ!

LES COMPOSANTS IDENTIFIÉS PAR UNE MARQUE  SUR LES DIAGRAMMES SCHÉMATIQUES ET LA LISTE DES PIÈCES SONT CRITIQUES POUR LA SÉCURITÉ DE FONCTIONNEMENT. NE REMPLACER CES COMPOSANTS QUE PAR DES PIÈCES SONY DONT LES NUMÉROS SONT DONNÉS DANS CE MANUAL OU DANS LES SUPPLÉMENTS PUBLIÉS PAR SONY.

FM STEREO/LW/MW/SW
PLL SYNTHESIZED RECEIVER
SONY[®]



TABLE OF CONTENTS

<u>Section</u>	<u>Title</u>	<u>Page</u>
Specifications	1
Features	2
SECTION 1. GENERAL	3
1-1.	Location and Function of Controls	3
1-2.	Supplied Accessories	3
1-3.	How to Set the Clock	4
1-4.	Direct Tuning	4
1-5.	Manual Tuning	5
1-6.	Scan Tuning	5
1-7.	Preset Tuning	6
1-8.	How to Turn on the Radio Automatically	6
1-9.	How to Set the Sleep Timer	7
1-10.	How to Use the Supplied Active Antenna	7
SECTION 2. OUTLINE	8
2-1.	Outline of the C-MOS Digital Tuning System IC801, μ PD1715G-545	8
2-1-1.	Outline of the Station Selection	8
2-1-2.	Description on the Terminals	8
2-1-3.	Description on the Terminals	8
2-1-3.	Initial State Setting	12
2-1-4.	Muting Output Timings	12
2-1-5.	Segment and Commons of Liquid Crystal Display Panel (LCD801)	14
2-1-6.	Relationship of LCD (LCD801) Segment to LSI Pin	14
SECTION 3. BLOCK DIAGRAM	15
SECTION 4. DISASSEMBLY	17
SECTION 5. ELECTRICAL ADJUSTMENTS	18
SECTION 6. DIAGRAMS	20
6-1.	Semiconductors Lead Layouts	20
6-2.	Circuit Boards Location	20
6-3.	Printed Wiring Boards	21
6-4.	Schematic Diagram	25
6-5.	IC Block Diagram	28
SECTION 7. EXPLODED VIEWS AND PARTS LIST	29
SECTION 8. ELECTRICAL PARTS LIST	31
SECTION 9. ANTENNA MODULE (AN-101)	36
9-1.	Exploded Views and Parts List	36

FEATURES

- An FM stereo/LW/MW/SW receiver with world-wide band coverage.
- Quartz controlled PLL (Phase Locked Loop) synthesizer system using a microcomputer for easy pinpoint tuning. The tuned frequency is digitally displayed.
- Direct tuning** .. Tuning in the station by inputting the frequency of the station directly
- Manual tuning** .. Even if you don't know the frequency of the station, you can tune in the station precisely.
- Scan tuning** An automatic searching of a station
- Preset tuning** ... Up to 10 stations can be preset for button-touch tuning
- Timer standby** .. The function to receive a desired station at the desired time
- Sleep timer** Turning the radio off automatically in 65 minutes
- Power sources** .. Three different power sources: internal batteries, house current, car batteries
With the supplied AC power adaptor, any AC power source is available.

Classification by frequency coverage

Distinations are classified by frequency indicated on LCD PANEL as the table below.

TYPE	FREQUENCY COVERAGE
TYPE 1-1, -2	FM 76 - 108 MHz AM 150 - 29,995 kHz
TYPE 2	FM 87.5 - 108 MHz AM 150 - 26,100 kHz
TYPE 3-1, -2	FM 87.5 - 108 MHz AM 150 - 29,995 kHz
TYPE 4 (Saudi Arabia)	FM 87.5 - 108 MHz AM 150 - 285/531 - 26,100 kHz

EXAMPLE

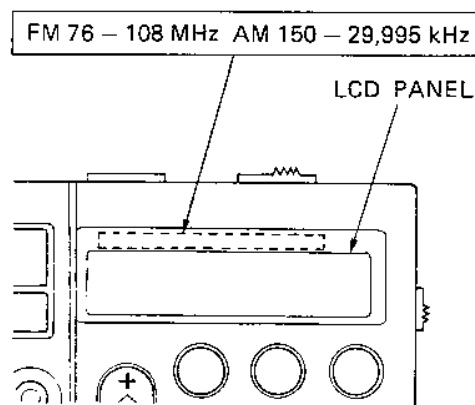

SECTION 1 GENERAL

1-1. LOCATION AND FUNCTION OF CONTROLS

Front Panel

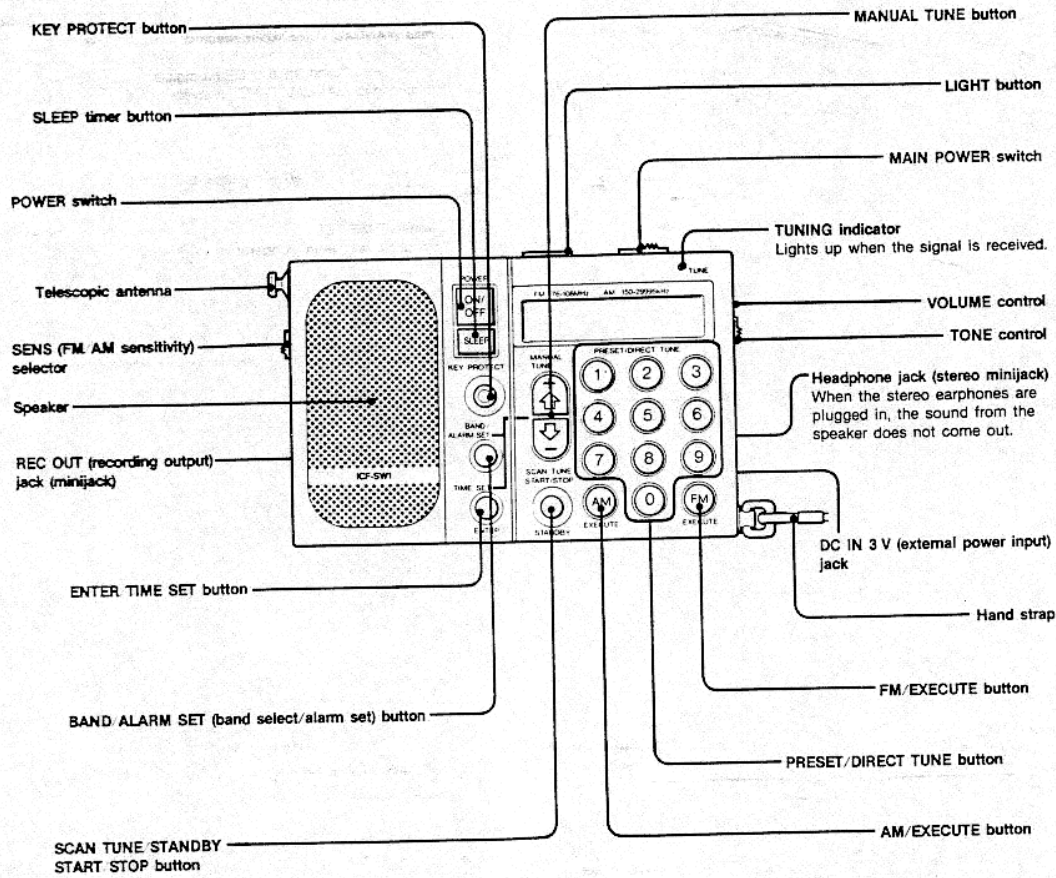

Rear Panel

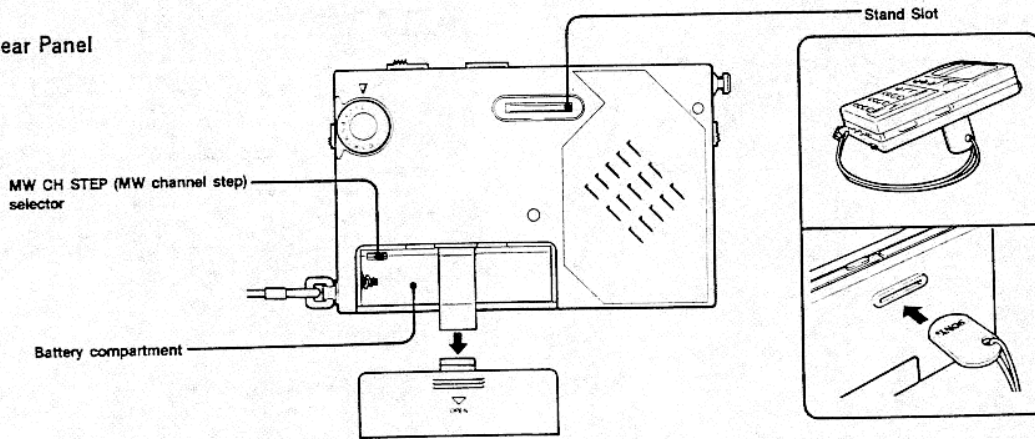

1-2. SUPPLIED ACCESSORIES

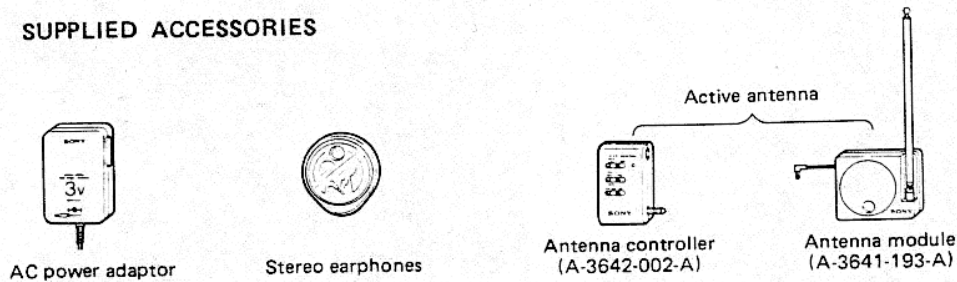

1-3. HOW TO SET THE CLOCK

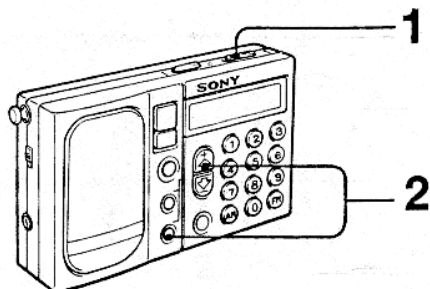

- 1 Set MAIN POWER to ON.
- 2 Press MANUAL TUNE while keeping TIME SET pressed to adjust the clock to the current time. To advance the time digits rapidly, keep MANUAL TUNE pressed. Press it to adjust the time indication precisely.

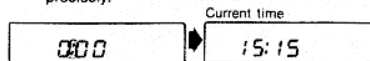

- 3 Release TIME SET.
The clock will begin to operate.

Setting the clock while listening to the radio
You cannot set the clock while you are listening to the radio. Be sure to press ON/OFF to turn the radio off and set the clock.

The display when MAIN POWER is OFF
The current time is displayed.

1-4. DIRECT TUNING

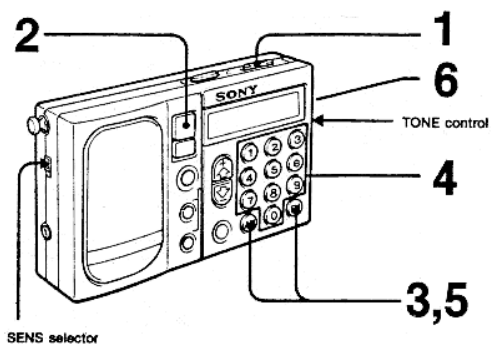

- 1 Set MAIN POWER to ON.
- 2 Press ON/OFF.
The radio is turned on.
- 3 Press the desired band (FM or AM) button.
To receive SW, MW, LW, press AM.
- 4 Input the frequency of the station by pressing DIRECT TUNE.
EX. AM. 810 kHz



- 5 Press the same band button again within 5 seconds.
The station will be tuned in.
- 6 Adjust the volume.
To turn off the radio, press ON/OFF.

To improve receiving condition

MW/LW



FM/SW

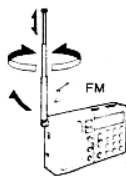
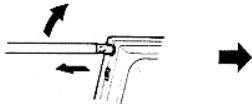

If you input a wrong frequency
Press FM EXECUTE or AM/EXECUTE again and input the correct frequency.

NOTICE
Reception of 1.8 MHz and 3.6 MHz may be difficult because of internal spurious signals generated by the built-in oscillators.

The inputted station is not tuned in
This occurs if you do not press the band button (FM or AM) within 5 seconds after inputting the frequency of the desired station and the tuned station's frequency will appear.
To tune in the desired station, repeat the same procedures from the third step.

1-5. MANUAL TUNING

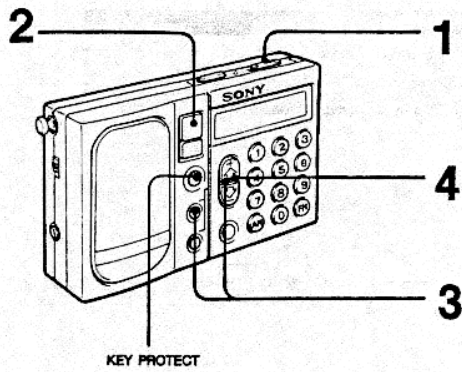

- 1 Set MAIN POWER to ON.
- 2 Press ON/OFF.
The radio is turned on.
- 3 Press MANUAL TUNE (+ or -) repeatedly while keeping BAND pressed to search for the approximate frequency of the desired station. The lowest frequency of each band or the meter band of SW appears in the display. If you keep MANUAL TUNE pressed, the band changes continuously.
- 4 Press MANUAL TUNE (+ or -) repeatedly to search for a desired station.

1-6. SCAN TUNING

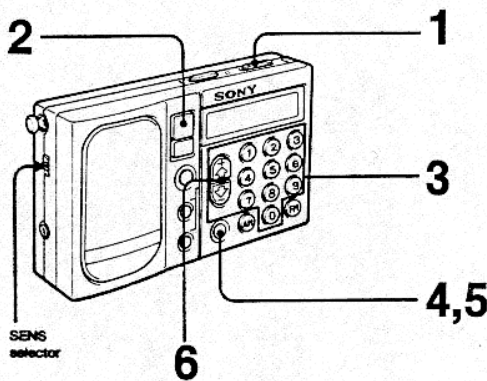

- 1 Set MAIN POWER to ON.
- 2 Press ON/OFF.
- 3 Receive a broadcast band by pressing MANUAL TUNE while keeping BAND pressed, or by pressing DIRECT TUNE. (Refer to the table below for the frequency range of each broadcast band.)
- 4 Press SCAN TUNE. Within the frequency range of the table below, scan tuning will begin and stop automatically for 1.5 seconds when a station is received and then the tuning indicator lights up.
- 5 Press SCAN TUNE again to listen to the station being received. Scan tuning stops and the station being received is tuned in.
- 6 Tune in the station more precisely by MANUAL TUNE (+ or -).

The frequency range and the tuning interval of each broadcast band

Broadcast band	Frequency range	SW meter band
LW	150 kHz ~ 528 kHz	
MW	531 kHz ~ 1611 kHz	*1
	530 kHz ~ 1610 kHz	
SW	1615 kHz ~ 2245 kHz	*2
	2250 kHz ~ 2550 kHz	120 meter band
	3150 kHz ~ 3450 kHz	90 meter band
	3850 kHz ~ 4050 kHz	75 meter band
	4700 kHz ~ 5100 kHz	60 meter band
	5900 kHz ~ 6250 kHz	49 meter band
	7000 kHz ~ 7400 kHz	41 meter band
	9400 kHz ~ 10000 kHz	31 meter band

*1 The frequency range is different according to the MW CH STEP selector.
*2 These frequencies can be tuned in either by direct tuning or manual tuning but cannot be selected by pressing both BAND and MANUAL TUNE buttons.

When scan tuning stops too often
Set SENS to LOCAL.
(For example, MW is so strong at night that many stations can be tuned in.)

Broadcast band	Frequency range	SW meter band
A M	11500 kHz ~ 12150 kHz	25 meter band
	13500 kHz ~ 13900 kHz	21 meter band
	15000 kHz ~ 15700 kHz	19 meter band
	17450 kHz ~ 18000 kHz	16 meter band
	21400 kHz ~ 21950 kHz	13 meter band
	25600 kHz ~ 26100 kHz	11 meter band
F M	26105 kHz ~ 29995 kHz	*3
	76.00 MHz ~ 106.00 MHz	

*3 These frequencies can be tuned in either by direct tuning or manual tuning but cannot be selected by pressing both BAND and MANUAL TUNE buttons.

The frequency allocation
LW...3 kHz
MW...9 kHz/10 kHz
SW...5 kHz
FM...100 kHz

1-7. PRESET TUNING

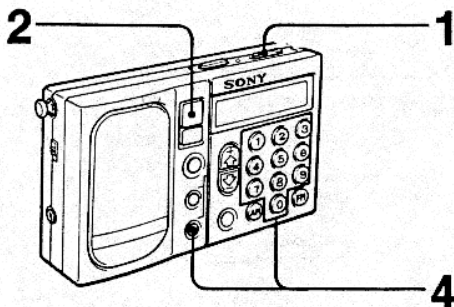

HOW TO PRESET A STATION

- 1 Set MAIN POWER to ON.
- 2 Press ON/OFF.
- 3 Tune in a desired station.
- 4 Press one of the PRESET buttons while keeping ENTER pressed.
The desired station is preset on that button.

Ex. FM 89.0 MHz



TO TUNE IN A PRESET STATION

- 1 Set MAIN POWER to ON.
- 2 Press ON/OFF.
- 3 Press the desired PRESET button.
The preset station will be tuned in.

The number of stations you can preset
Up to 10 stations of either an FM or
AM can be preset to PRESET.

To change the preset station
Preset a station to the desired PRESET
button. The station previously preset to
the button is erased.

1-8. HOW TO TURN ON THE RADIO AUTOMATICALLY
(Timer standby function)

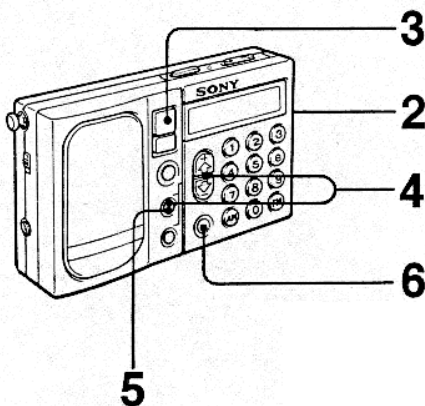

- 1 Tune in the station which you want to listen to at the desired time.
- 2 Adjust the volume.
- 3 Press ON/OFF.
The radio will be turned off.
- 4 Set the time by pressing MANUAL TUNE (+ or -) while keeping ALARM SET pressed. If you keep MANUAL TUNE pressed, the time will change continuously.
- 5 Stop pressing ALARM SET and the current time appears in the display.
- 6 Press STANDBY. STANDBY indicator will continue to be displayed.

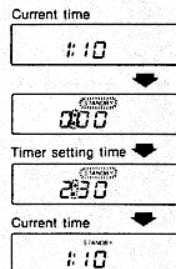

To cancel the alarm mode
Either press STANDBY or set MAIN POWER to OFF.

Once you preset the time
The radio is turned on at the same
time everyday.

To check the preset time
Press ALARM/SET.

To change the preset time
Set the desired alarm time, the time
previously set is erased.

1-9. HOW TO SET THE SLEEP TIMER

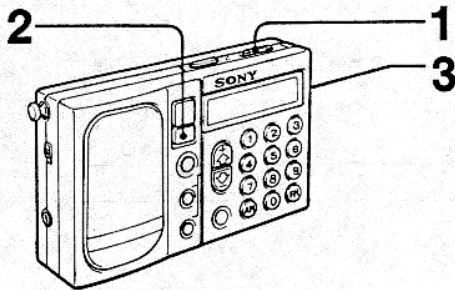

1 Set MAIN POWER to ON.

2 Press SLEEP.
The radio is turned on.

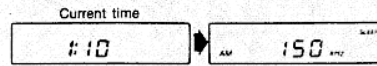

3 Tune in the desired station and adjust the volume.

The radio will be turned off automatically after about 65 minutes.

When you press SLEEP while listening to the radio
The radio will be turned off automatically after about 65 minutes.

To turn off the radio before the sleep time
Press ON/OFF.

If you press SLEEP after the radio is turned off
The sleep timer activates and the last station to be tuned in will be received.

1-10. HOW TO USE THE SUPPLIED ACTIVE ANTENNA (For better LW/MW/SW reception)

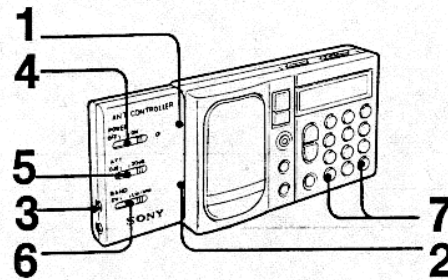
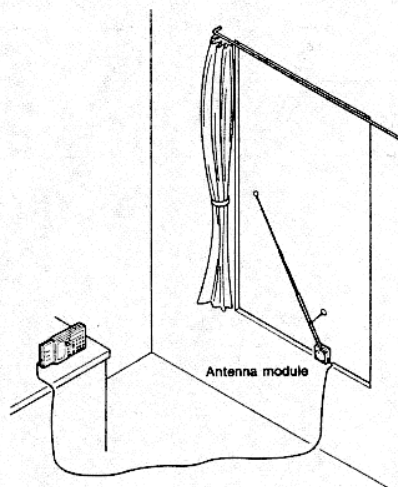

1 Set SENS of the radio to DX.

2 Collapse the rod antenna and install the antenna controller to the radio.

3 Pull out the output cable from the antenna module and plug it into the FROM MODULE jack.

4 Set POWER to ON.
The power indicator lights up.

5 Set ATTENUATOR to 0 dB.

6 Set BAND to the desired band.

7 Select the same band on the radio and tune in the desired station.

8 Extend the telescopic antenna of the antenna module.

SECTION 2 OUTLINE

2-1. OUTLINE OF THE C-MOS DIGITAL-TUNING SYSTEM IC801, μ PD1715G-545

2-1-1. OUTLINE OF THE STATION-SELECTION

1) Receiving-frequency Coverages and Scan Range

The following table shows the frequency coverages and scan range of μ PD1715G-545 can receive.

BAND	SCAN RANGE	CHANNEL SEPARATION	NOMINAL SPACING
LW	150 kHz – 528 kHz	3 kHz	3 kHz
MW1	531 kHz – 1,611 kHz	9 kHz	3 kHz
MW2	530 kHz – 1,610 kHz	10 kHz	5 kHz
SW	1,615 kHz – 2,550 kHz	5 kHz	5 kHz
	2,555 kHz – 3,450 kHz	5 kHz	5 kHz
	3,455 kHz – 4,050 kHz	5 kHz	5 kHz
	4,055 kHz – 5,100 kHz	5 kHz	5 kHz
	5,105 kHz – 6,250 kHz	5 kHz	5 kHz
	6,255 kHz – 7,400 kHz	5 kHz	5 kHz
	7,405 kHz – 10,000 kHz	5 kHz	5 kHz
	10,005 kHz – 12,150 kHz	5 kHz	5 kHz
	12,155 kHz – 13,900 kHz	5 kHz	5 kHz
	13,905 kHz – 15,700 kHz	5 kHz	5 kHz
15,705 kHz – 18,000 kHz	5 kHz	5 kHz	
18,005 kHz – 21,950 kHz	5 kHz	5 kHz	
21,955 kHz – 26,100 kHz	5 kHz	5 kHz	
26,105 kHz – 29,995 kHz	5 kHz	5 kHz	
FM1	76.00 MHz – 108.00 MHz	100 kHz	12.5 kHz
FM2	87.50 MHz – 108.00 MHz	50 kHz	12.5 kHz

2) Station-selecting Functions:

- a) Selection with 10 key.
- b) Manual up/down selection with up/down key.
- c) Random selection out of the preset memories by key-in calling.
Total 10 stations.
- d) Scanning selection.
- e) Last channel memory.

2-1-2. DESCRIPTION ON THE TERMINALS

1) Terminal Arrangement

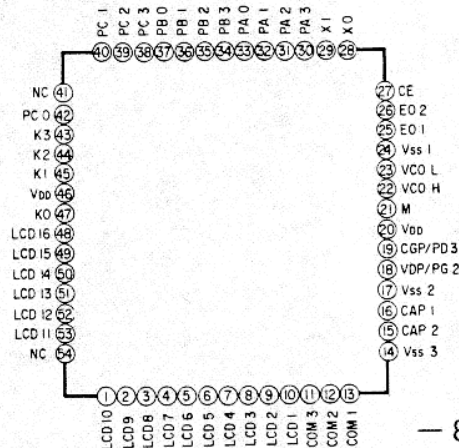

2) IC801 (μ PD1715G-545) Pin Functions

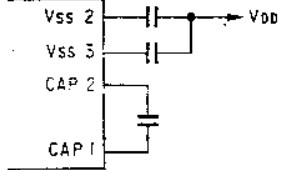
PIN No.	SYMBOL	NAMING	DESCRIPTION
1 10	LCD9 LCD1	LCD SEGMENT SIGNALS	Transmit the segment-output signals to the LCD panel. When matrixes are configured together with the COM1 thru COM3, a display of 48 dots can be made. These output signals are output when the LCDD commands are made. The LCD-driving voltages are of 3.1V typical, 1/2 bias and 1/3 duty when the frame frequency is 100 Hz. These LCD11 through LCD16 can also be used at the same as the key source signals for the key matrix. These signal are output on time-division bases, and they are output as the key-source signals at the repetition rate of 6.7 msec. Whether the key-source signal are to be output while having displays on the panel is dependent upon and selectable by the programs used. These terminals become automatically in the "L" (low) state, i.e., non-display mode, at the power-on reset (VDD changes from low to high state) and at the stoppage moment of the clock. The display mode does not change at the reset moment in which CE changes from low to high state.
11 13	COM3 COM1	LCD COMMON SIGNAL	Transmit common signals to the LCD panel. When the matrixes are configured together with the LCD1 through LCD16, a display of 48 dots can be made. Three distinctive signals of VSS3, VSS2 and VDD are output through these terminals at the repetition rate of 50 Hz. These terminals become automatically in the "L" (low) state, i.e., non-display mode, at the power-on reset (VDD changes from low to high state) and at the stoppage moment of the clock.
14 15 16 17	VSS3 CAP2 CAP1 VSS2	CAPACITOR CONNECTION TERMINAL FOR DOUBLER	Capacitor-connection terminals to make a proper voltage doubler to build the 3.1V typical LCD-driving voltage VDD. Normal circuit configuration is as follows. 
18	PG2 (VDP)	VARIABLE DUTY PORT	Outputs the variable-duty or the one-bit (PG2) signal. Not used.
19	PD3 (CGP) MUTE	CLOCK GENERATOR PORT (MUTE SIGNAL)	Outputs the clock-generator or the one-bit (PD3) signal. The selection of either of them is programmable. When used as the CGP, this terminal can transmit the pulse chain of 1 kHz of 46.6% duty or 3 kHz of 60% duty. In this set, this port outputs a signal to mute noises encountered in the unlocked condition of the PLL. When "L" (low) outputs, it mute.
20	VDD	INPUT OF POWER SUPPLY VOLTAGE	Receives the power-supply voltage for this device. In operation, a voltage of 1.8 to 3.6 VDC is applied to this terminal. The input voltage can be lowered down to 1.5 VDC when any of the internal data in the RAM, i.e., when the CKSTP command is under execution, is to be holded. The power-on reset circuit of device starts to operate at the instance this terminal receives a voltage of 0 (zero) to 1.8 VDC, and the program starts from the location 0 (zero). Note: This pin and pin 46 are connected internally. So, it is not necessary to apply the power-supply voltage to both of them. The ceramic-packaged device, however, has a not-to-be connected pin 46, i.e., N.C. terminal.
21	M	CONTROL- SIGNAL INPUT FOR DIVIDER	Determines the dividing ratio of the fixed-division prescaler. A 1/4 dividing ratio is made when this terminal is held at "H" (high), and a 1/2 divider is made when held at "L" (low). This port is used only when the VCOH terminal (FM in this set) i.e., pin 22 is used. This set uses this port as a 1/4 divider for PM and 1/2 divider for AM.
22	VCOH	OSC SIGNAL INPUT	Inputs 1/4 divider 10 ~ 130 MHz (0.1 Vp-p MIN.) or 1/2 divider 10 ~ 100 MHz (0.1 Vp-p MIN.) of local-oscillator output, i.e., the VCO output. This input signal is connected internally in this device through the 1/2 fixed-divider prescaler or the 1/4 fixed-divider prescaler and through the two-module prescaler composed of 1/32 and 1/33 frequency dividers to the internal programmable counter. This terminal is pulled down to the ground level when the direct frequency-dividing system is taken into the circuit or when the Pulse-Swallow system is used with the HF command executed, i.e., the VCOL (AM) terminal is selected. A capacitor coupling is needed due to the inclusion of alternate current amplifiers inside this device.

PIN NO.	SYMBOL	NAMING	DESCRIPTION															
23	VCOL		<p>Receives an AM local-oscillator signals, i.e., the VCO signal from 0.5 MHz to 40 MHz of 0.2 Vp-p minimum.</p> <p>This port is selected when the direct frequency-dividing system or the Pulse-Swallow system is used and, at the same time, the HF command is executed. These two systems are, however, different one another as shown below.</p> <table border="1" style="width: 100%; border-collapse: collapse;"> <thead> <tr> <th>DIVIDING SYSTEM</th> <th>INPUT LEVEL (MINIMUM)</th> <th>INPUT FREQUENCY</th> <th>DIVIDING RATIO</th> </tr> </thead> <tbody> <tr> <td>DIRECT</td> <td>0.1 Vp-p</td> <td>0.5 to 15 MHz</td> <td>16 to $(2^{12}-1)$</td> </tr> <tr> <td>PULSE-SWALLOW (HF COMMAND EXECUTED)</td> <td>0.2 Vp-p</td> <td>0.5 to 40 MHz</td> <td>1,024 to $(2^{17}-1)$</td> </tr> </tbody> </table> <p>This terminal is pulled down to the ground level when the Pulse-Swallow system is used together with the VHF-command execution, i.e., the VCOH (FM) terminal is selected. A capacitor coupling is needed due to the inclusion of alternate current amplifiers inside this chip. Not used.</p>	DIVIDING SYSTEM	INPUT LEVEL (MINIMUM)	INPUT FREQUENCY	DIVIDING RATIO	DIRECT	0.1 Vp-p	0.5 to 15 MHz	16 to $(2^{12}-1)$	PULSE-SWALLOW (HF COMMAND EXECUTED)	0.2 Vp-p	0.5 to 40 MHz	1,024 to $(2^{17}-1)$			
DIVIDING SYSTEM	INPUT LEVEL (MINIMUM)	INPUT FREQUENCY	DIVIDING RATIO															
DIRECT	0.1 Vp-p	0.5 to 15 MHz	16 to $(2^{12}-1)$															
PULSE-SWALLOW (HF COMMAND EXECUTED)	0.2 Vp-p	0.5 to 40 MHz	1,024 to $(2^{17}-1)$															
24	Vssl	GROUND	The ground-return terminal of this device.															
25 26	E01 E02	ERROR OUTPUT ERROR OUTPUT	<p>Transmits the error signal of the PLL system. When the resultant frequencies obtained by dividing the local-oscillator frequencies are higher than the reference frequency, an "H" (high)-level signal is output from this port. When these are lower, on the contrary, an "L" (low)-level signal is output from this port. When these divided frequencies just coincide with the reference frequency, this port becomes in a floating state. These output signals from this port then go through the external lowpass filter to the varactor diodes in the turned circuits in these frontends of the receiver. The same output waveform as the terminal E01 is obtainable from the next terminal E02, pin 26, and so these two are user-selectable. When the PLL is disabled, i.e., when the system is set by the PLL commands or the CE terminal, pin 27, is set to the "L" (low)-level, these E01 and E02 terminals become in the floating states.</p>															
27	CE	CHIP ENABLE	<p>Receives the state-selection signals for this device.</p> <p>When set a "H" (high), this device works, and vice versa. The PLL section of this device becomes forcibly in a disabled condition in the duration of wider than 140 μsec of the "L" (low)-level state. The duration, however, of shorter than 140 μsec is not taken into account. The programmes are using the CKSTP commands. The CKSTP commands are effective only when the state of this CE is in an "L" (low) condition. When this CE terminal is in an "H" state, these programmes work like under NOP commands.</p> <p>When the CKSTP commands are executed when this CE terminal is in an "L" (low) level, the internal clock generator and the internal CPU are disabled. In this disabled condition, the RAM-memory backupings can be made under a very-low current consumption of 3 μA maximum. In this condition, these display-output signals LCD1 through LCD16 and the COM1 COM3 become in the off-display mode, i.e., the "L" (low) state.</p> <p>When the level of this CE terminal is changed from "L" to "H", this device is reset and its programmes start from the location "0" (zero). In this state, the Port A becomes in the input mode.</p> <p>Goes to "L" (low) when main power switch is OFF or when the power supply is below 1.9V (1.8 - 2.0 V).</p>															
28 29	XO X1	CRYSTAL OSCILLATOR	An external quartz-crystal oscillator connects to these terminals to obtain 75 kHz signal generator for the devices.															
30 33	PA3 PA0	PORT A	<p>4-bit I/O (Input/Output) ports. These ports enable the device designate input or output bit by bit. The each designation is, in turn, performed by the contents in the location "1FH" in the "BANK 0 (zero)" in the data memory (RAM), called as a "PAIO word". At these instances as the power-on, clock stoppage and the initial setting of the CE terminal from "L" to "H", these terminals automatically become in the input ports.</p> <p>Under the port-operation commands like "IN", "OUT", "SPB", "RPB" commands, etc., the PA0 port coincides with the least significant bit of the register or the operand, the PA3 coincides with the most-significant bit of them. The same applies to the port B and Port C respectively.</p>															
(30) (31) (32) (33)	PA3 (SD) PA2 PA1 PA0	PORT A PORT A PORT A PORT A	<p>When receiving a broadcast station, it goes to "H" (high), and tuning LED lights. It is used as a stop signal for scan function.</p> <p>Initial key input port.</p> <p>Mode output.</p> <table border="1" style="width: 100%; border-collapse: collapse;"> <thead> <tr> <th></th> <th>RADIO OFF</th> <th>LW/MW</th> <th>SW</th> <th>FM</th> </tr> </thead> <tbody> <tr> <td>PA1</td> <td>"L"</td> <td>"L"</td> <td>"H"</td> <td>"H"</td> </tr> <tr> <td>PA0</td> <td>"L"</td> <td>"H"</td> <td>"L"</td> <td>"H"</td> </tr> </tbody> </table>		RADIO OFF	LW/MW	SW	FM	PA1	"L"	"L"	"H"	"H"	PA0	"L"	"H"	"L"	"H"
	RADIO OFF	LW/MW	SW	FM														
PA1	"L"	"L"	"H"	"H"														
PA0	"L"	"H"	"L"	"H"														

PIN NO.	SYMBOL	NAMING	DESCRIPTION
34 37	PB3 PB0	PORT B	<p>4-bit exclusive output ports.</p> <p>For ports PB0 and PB1, the sink current is minimized to a specially-low drain, so the PB0 and PB1 are able to be used as the return-signal sources for the key matrix. Accordingly any of the reverse-current-preventive diodes can be eliminated when these PB0 and PB1 ports are used as the key-return-signal sources. When these ports are used as ordinal output ports, it will happen any of the low-level output signal will not be output properly depending upon the circuit employed, because of the low sink current. In these cases, pull-down resistors are used in these output lines.</p> <p>Under the port-operation commands like "IN", "OUT", "SOB", "RPB" commands, etc., the PA0 port coincides with the least significant bit of the register or the operand, the PA3 coincides with the most-significant bit of them. The same applies to the Port B and Port C respectively. These exclusive output ports should be initialized using the programmes, because these ports output unstable and undefined output signals at the initial power-on condition, i.e., from "L" to "H".</p> <p>The output-data contents are the same as these previous last ones when the CE terminal changes from "L" to "H" or from "H" to "L", and when the CKSTP commands are under execution. Accordingly, the initialization with programmes is needed too where required. In this set, these ports are used as those shown in the parentheses.</p>
(34)	PB3 (3 kHz)	PORT B	First local frequency control: In LW and MW (in 9 kHz step), if 5 is left when the receiving frequency divided by 6, it outputs "L" (low). If divisible by 6, outputs "H" (high).
(35)	PB2 (5 kHz)	PORT B	First local frequency control: In MW (in 10 kHz step) and SW, if 5 is left when the receiving frequency divided by 10, it outputs "L" (low). If divisible by 10, outputs "H" (high).
(36)	PB1	PORT B	Key matrix key lease signal.
(37)	PB0	PORT B	
38 40	PC3 PC1	PORT C (KEY- MATRIX SIGNAL- SOURCE OUTPUT)	<p>Refer to the PORT B outlined above. All the ports of this PORT C apply to the description for the PORT B.</p> <p>In this set, these ports output signals to be used as the signal sources for the key matrix.</p>
41	NC	NO	This is a free terminal and is not connected to the internal circuits, and this terminal can be used as a junction land.
42	PC0	PORT C	Refer to description for pins 38 through 40 outlined above.
43 45	K3 K1	KEY INPUTS	4-bit exclusive input ports. These are normally used as the key-matrix input terminals. When the KIN or the KI commands executed, the conditions of these pins are read into the RAM data memories designated by the operand portion of these commands.
46	VDD		Same as pin 20.
47	K0		Same as pins 43 through 45.
48 53	LCD16 LCD11		Same as pins 1 through 10.
54	NC		Same as pin 41.

2-1-3. INITIAL-STATE SETTING

1) Initial Power-on Setting:

VDD = 0 V → 3.0 V, CE = Low → High

The power-supply is reset after performing the initial power-on setting, and the following operations are made.

- a) The power-out terminal becomes in "L" (low) state, i.e., power off, and reads the initial-state setting diodes.
- b) Initializes the preset-memories contents of each figures from 0 to 9 to its 150 kHz frequency.
- c) Initializes the last-channel memories contents of the above each cases to its 150 kHz frequency.
- d) Sets the clock and alarm time to "0:00", and resets the "second" starting.
- e) And the LCD displays the following clock display.



2) Backup Condition:

CE = Low

The backup state is made when the CE terminal becomes in "L" (low) state. In the backup state, the program routines are intermittently performed to eliminate the current drain by using the "HALT" command. The operation routine is as follows.

- a) The PLL is disabled.
- b) All the ports are made into "L" (low) state.
- c) LCD displays remains only for the clock display.

Note: The same operations are made in the radio-off state when CE is "H" (high).

2-1-4. MUTING-OUTPUT TIMINGS

1) MUTE-OUTPUT

The muting-output timings are classified as follows.

a) Radio On

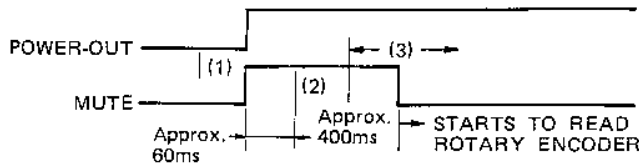

b) Radio Off

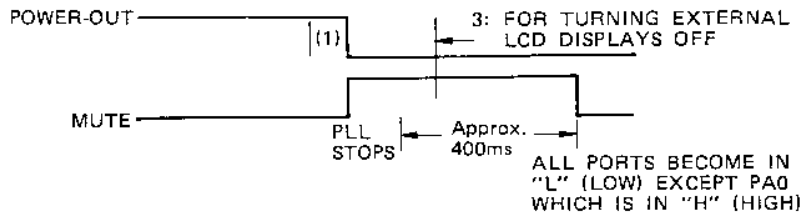

c) Preset-memory Callings, Band Changings and Meterband Changings:

c-1) One-time Key Hitting:

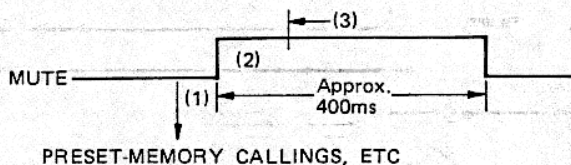

c-2) Meterband Changings with ← or → Switch Kept Depressed (Continuous/Successive Changings)

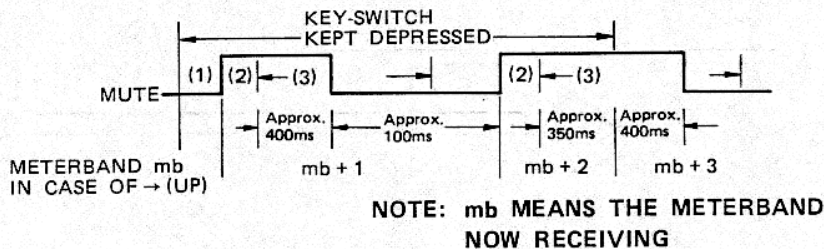

d) Station Selection with Rotary Encoder:

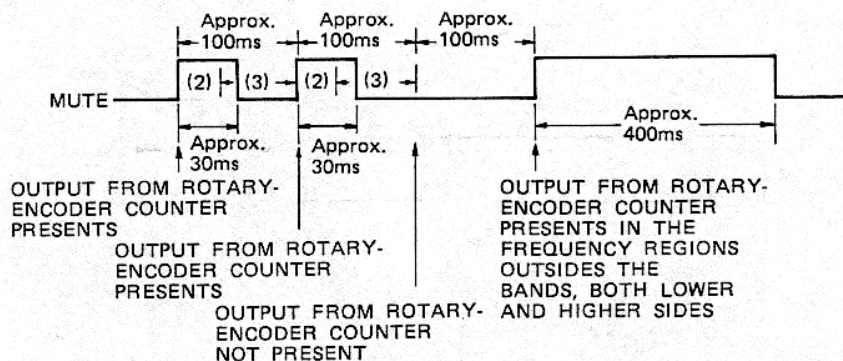

e) Power On by Alarm Operation

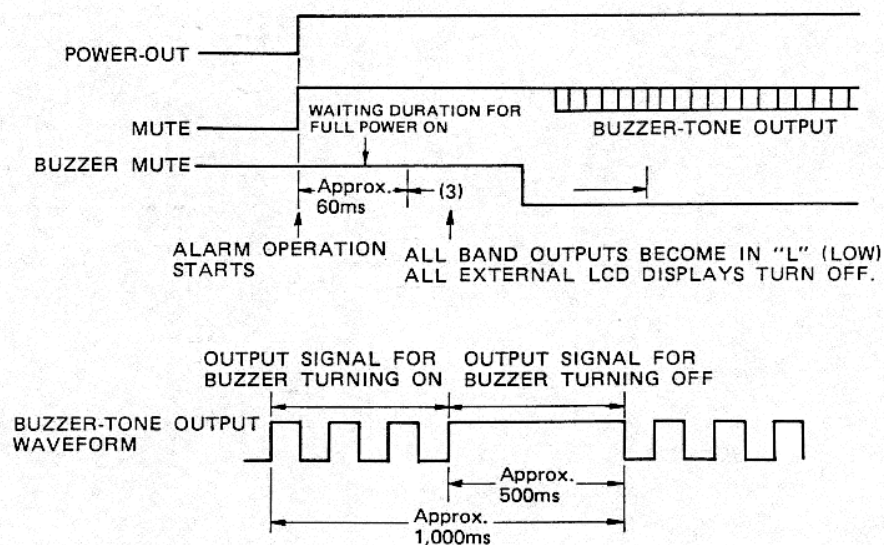

2-1-5. SEGMENTS AND COMMONS OF LIQUID-CRYSTAL DISPLAY PANEL (LCD801)

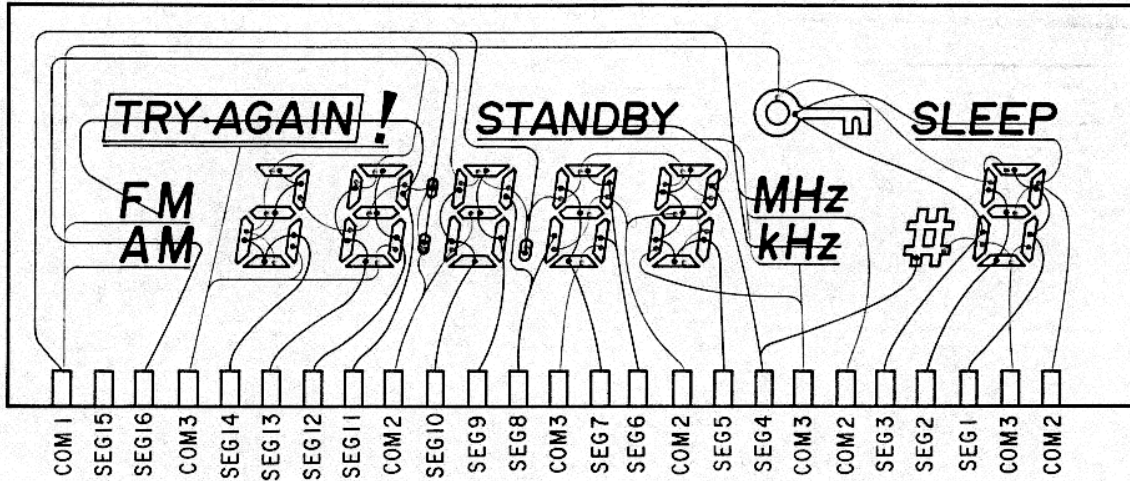

2-1-6. RELATIONSHIP OF LCD (LCD801) SEGMENTS TO LSI PINS

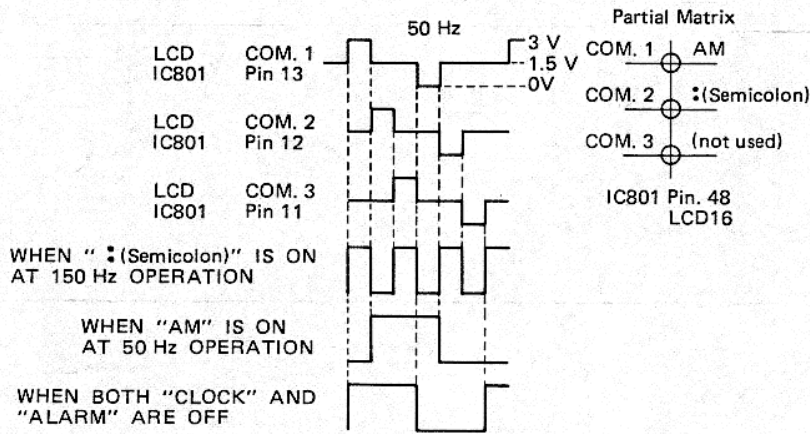

SECTION 4 DISASSEMBLY

Note: Follow the disassembly procedure in the numerical order given.

REAR CABINET

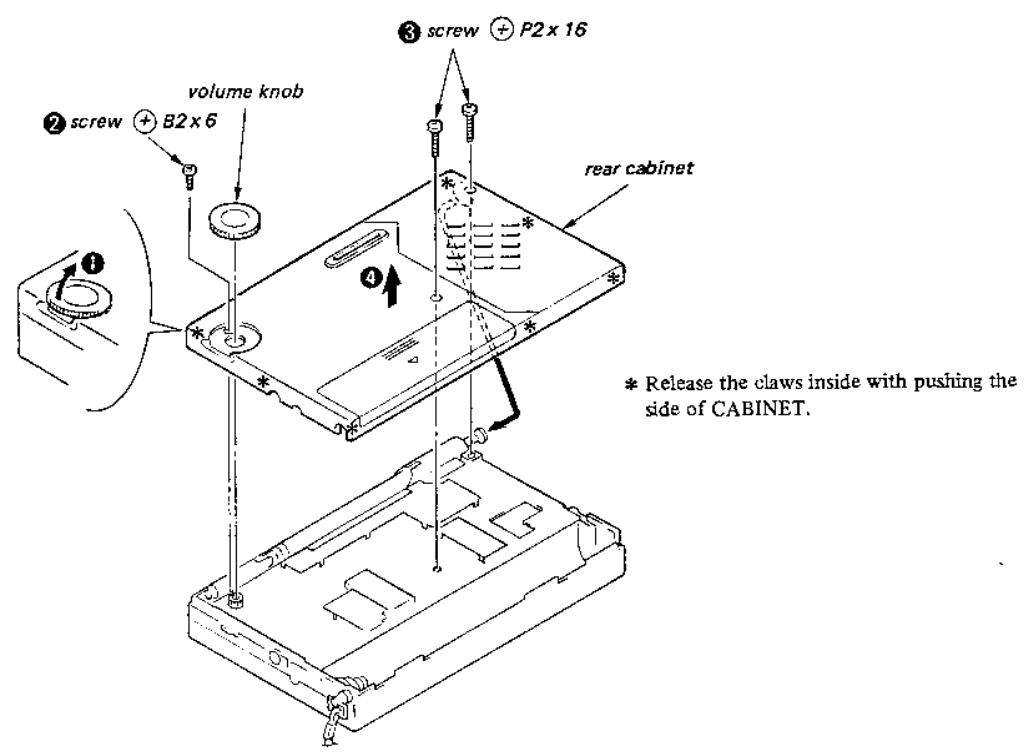

CHASSIS

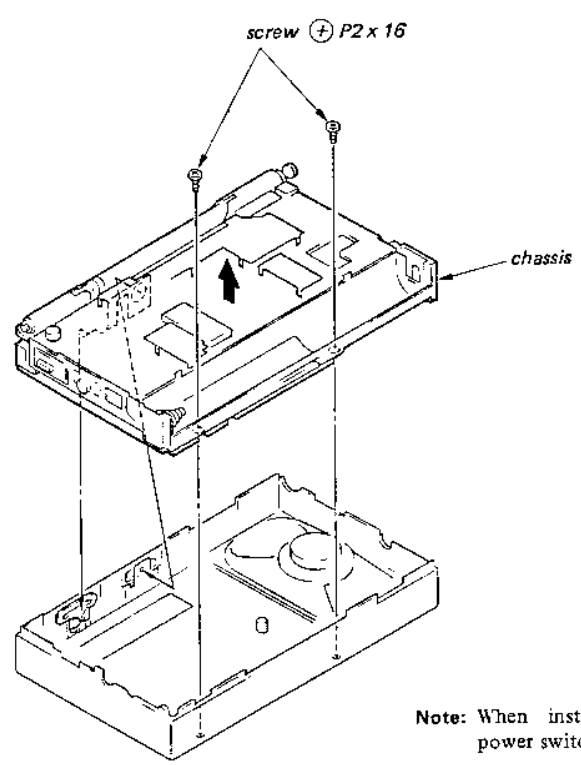

SECTION 5 ELECTRICAL ADJUSTMENTS

- Parts location diagram relevant to the adjustment

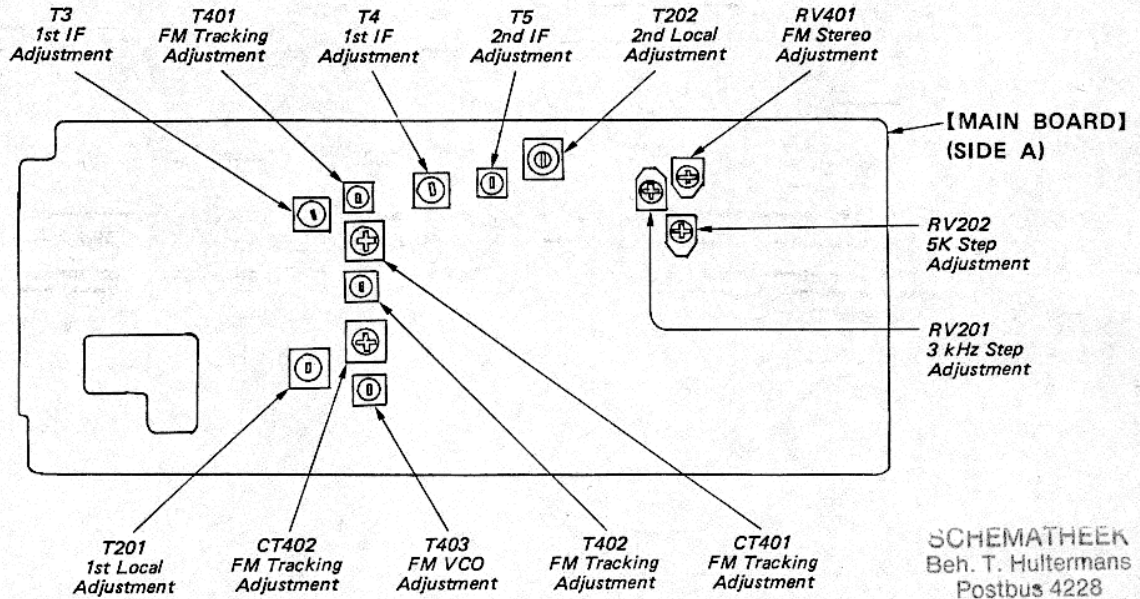

• AM SECTION

1st LOCAL ADJUSTMENT

Setup:

VOLUME control: as required

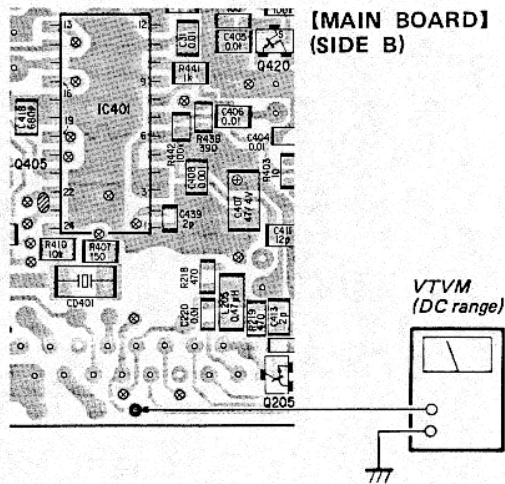

Procedure:

1. Tune the set to AM 150 kHz.
2. Adjust T201 to obtain a 2.59 – 2.61 V on the VTVM.
3. Tune the set to AM 29.995 MHz.
4. Confirm that the voltage reading on the VTVM is less than 12 V.

2nd LOCAL ADJUSTMENT/3 kHz STEP/5 kHz STEP ADJUSTMENT

Setup:

VOLUME control: as required

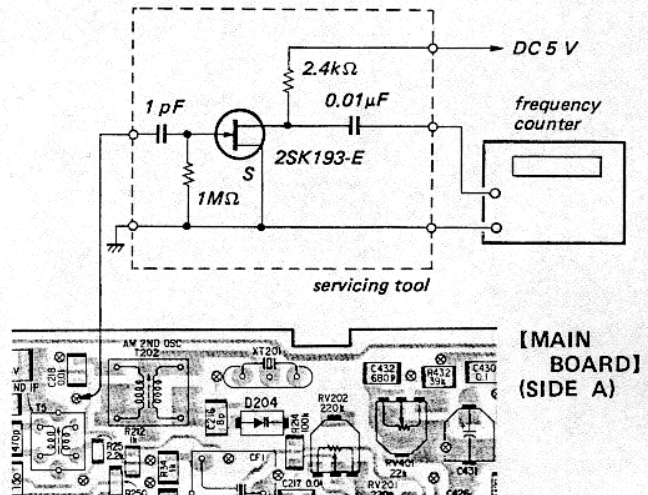

Procedure:

- 2nd LOCAL ADJUSTMENT
 1. Tune the set to AM 153 kHz.
 2. Adjust T202 to obtain a 55.3899 – 55.3901 MHz on the frequency counter.
- 3 kHz STEP ADJUSTMENT
 3. Tune the set to AM 156 kHz.
 4. Adjust RV201 to obtain a 55.3869 – 55.3871 MHz on the frequency counter.
- 5 kHz STEP ADJUSTMENT
 5. Tune the set to AM 1,620 kHz.
 6. Adjust RV202 to obtain a 55.3850 MHz on the frequency counter.

NOTE: This adjustment should be performed after the remove Rod-Antenna (ANT1).
This adjustment should be performed after the FM FREQUENCY-COVERAGE ADJUSTMENT.

1st/2nd IF ADJUSTMENT

Setup:

VOLUME control: as required

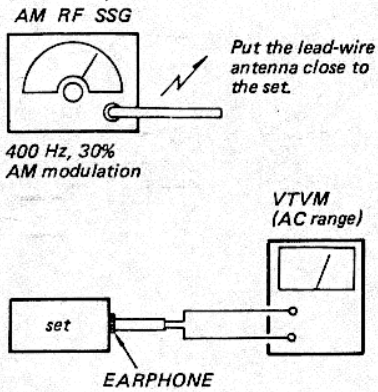

Procedure:

- 1st IF ADJUSTMENT
 1. Set the frequencies of the AM RF SSG and the frequency display of the set to 156 kHz.
 2. Adjust T3 and T4 to obtain a maximum reading on the VTVM.
- 2nd IF ADJUSTMENT
 1. Set the frequencies of the AM RF SSG and the frequency display of the set to 156 kHz.
 2. Adjust T5 to obtain a maximum reading on the VTVM.

● FM SECTION

FM FREQUENCY COVERAGE (VCO VOLTAGE) ADJUSTMENT

Setup:

VOLUME control: as required

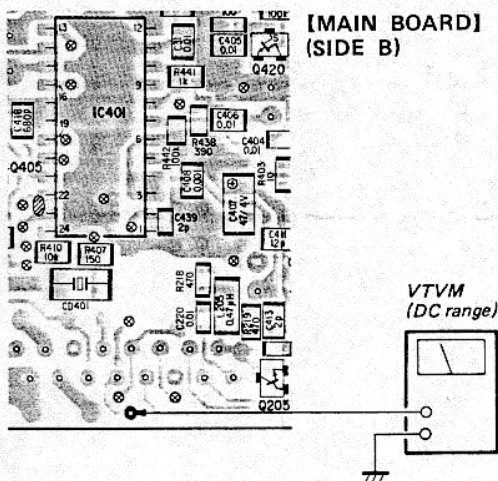

Procedure:

1. Tune the set to 108 MHz.
2. Adjust T403 to obtain a 11.9 - 12.1 V on the VTVM.

FM TRACKING ADJUSTMENT

Setup:

VOLUME control: as required

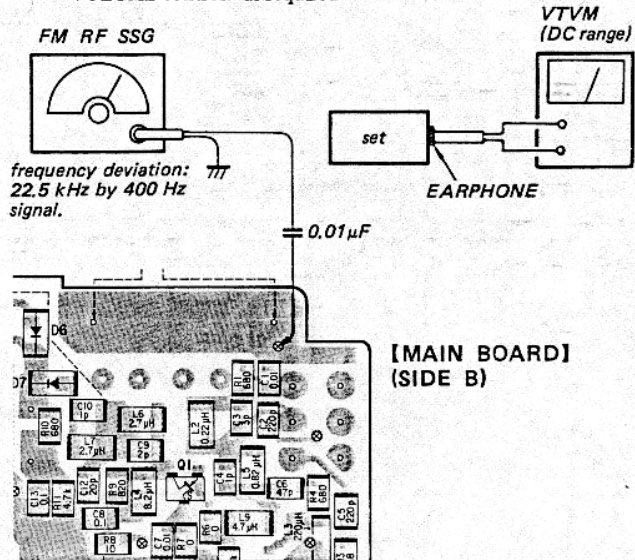

Procedure:

1. Set the frequencies of the FM RF SSG and the frequency display of the set to 76 MHz.
2. Adjust T401 and T402 to obtain a maximum reading on the VTVM.
3. Set the frequencies of the FM RF SSG and the frequency display of the set to 108 MHz.
4. Adjust CT401 and CT402 to obtain a maximum reading on the VTVM.
5. Repeat the above steps several times, and finish the adjustment with the trimmers CT401 and CT402.

FM STEREO ADJUSTMENT

Setup:

VOLUME control: as required

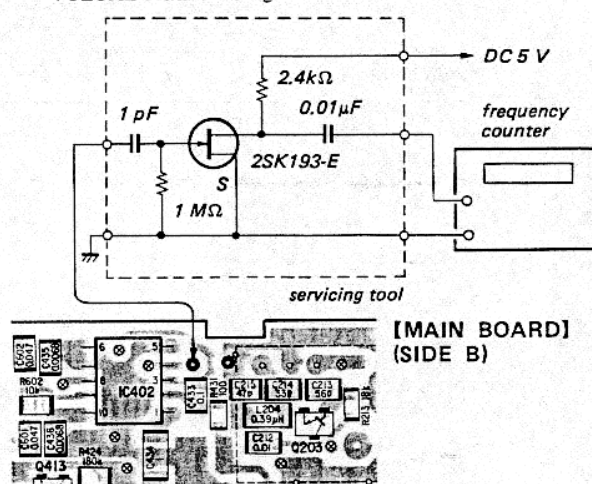

Procedure:

1. Adjust RV401 to obtain a 75.9 - 76.1 kHz on the frequency counter.

SECTION 6 DIAGRAMS

6-1. SEMICONDUCTORS LEAD LAYOUTS

<p>S-8051HN-CD-S</p>	<p>CX20111</p> <p>(Top view)</p>	<p>XN1215</p>	<p>1SS303</p>	<p>RD13M-B2</p>	<p>TLUR122</p>
<p>BA5208AF</p> <p>(Top view)</p>	<p>LA5002M</p> <p>(TOP VIEW)</p>	<p>2SK94-X2 2SK613-3</p>	<p>1SS123</p>	<p>XN5501</p>	
<p>LA3335M</p> <p>(Top view)</p>	<p>μPD1715G-545-22</p>	<p>DTC114TU DTC124EV</p>	<p>1SS304</p>	<p>XN4608</p>	
<p>μPD74HC239G</p> <p>(TOP VIEW)</p>	<p>2SB815 2SC3624A-L16 2SC4-177 2SC4178 2SD1048</p>	<p>2SK238-K16</p>	<p>1SS279 1T33</p>	<p>TLG123A</p>	

6-2. CIRCUIT BOARDS LOCATION

SCHEMATHEEK
Beh. T. Hultermans
Postbus 4228
6500 EE Eindhoven

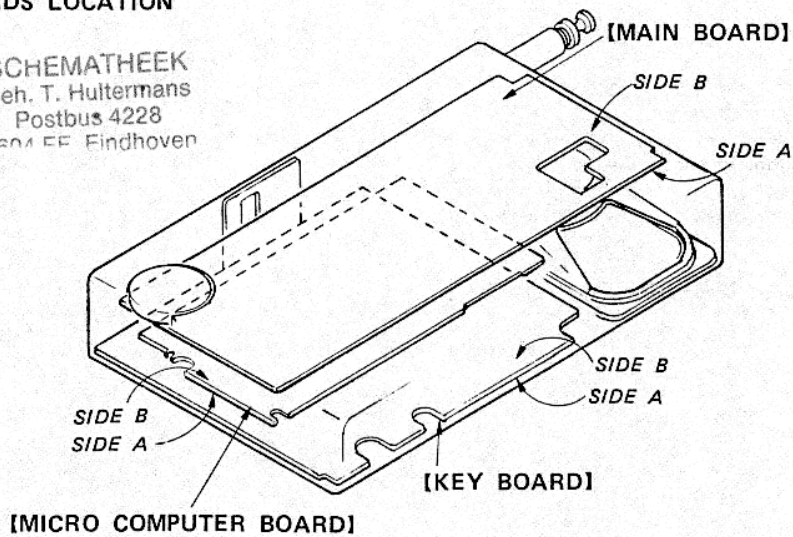

SECTION 3 BLOCK DIAGRAM

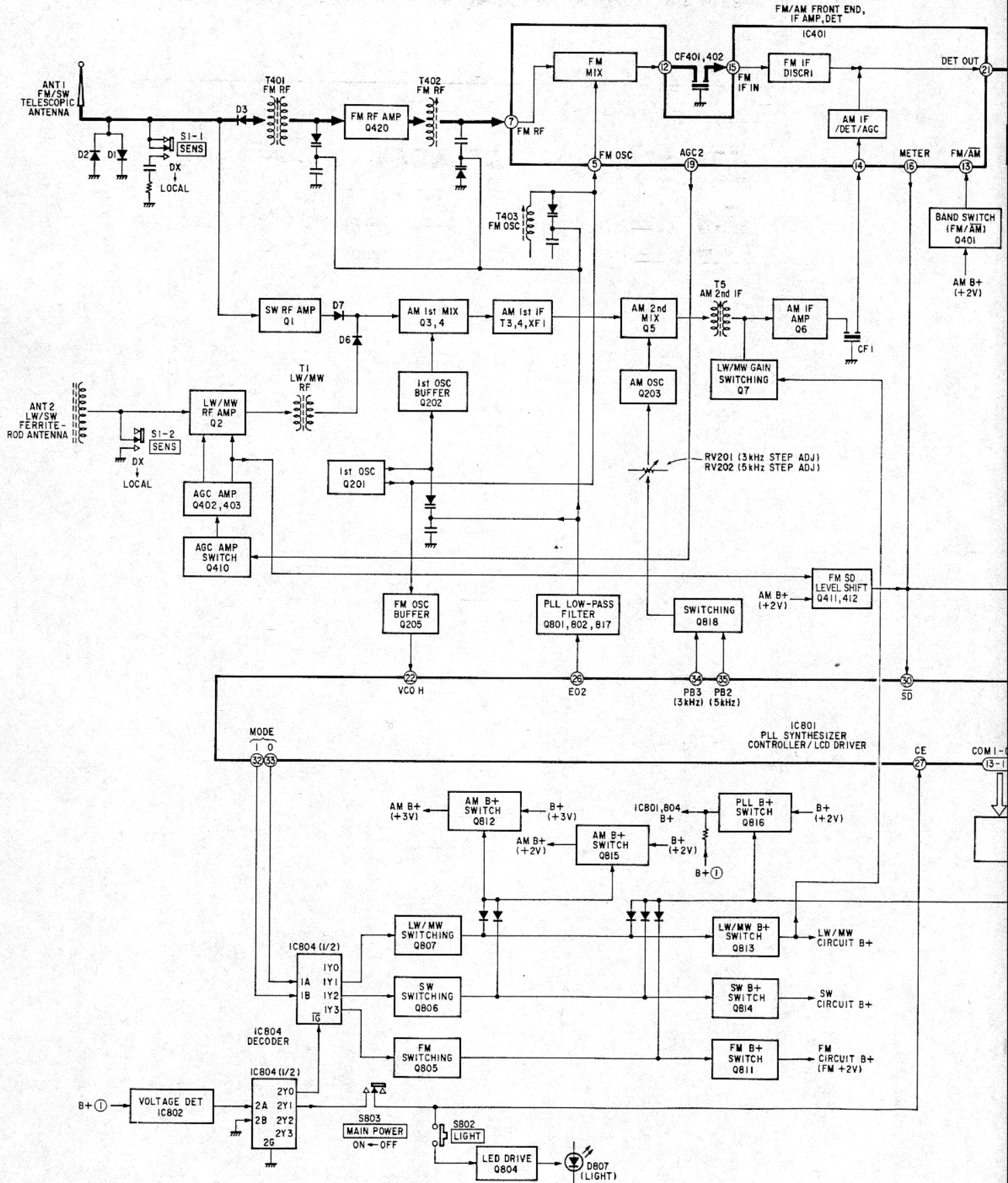

ICF-SW1
AN-101

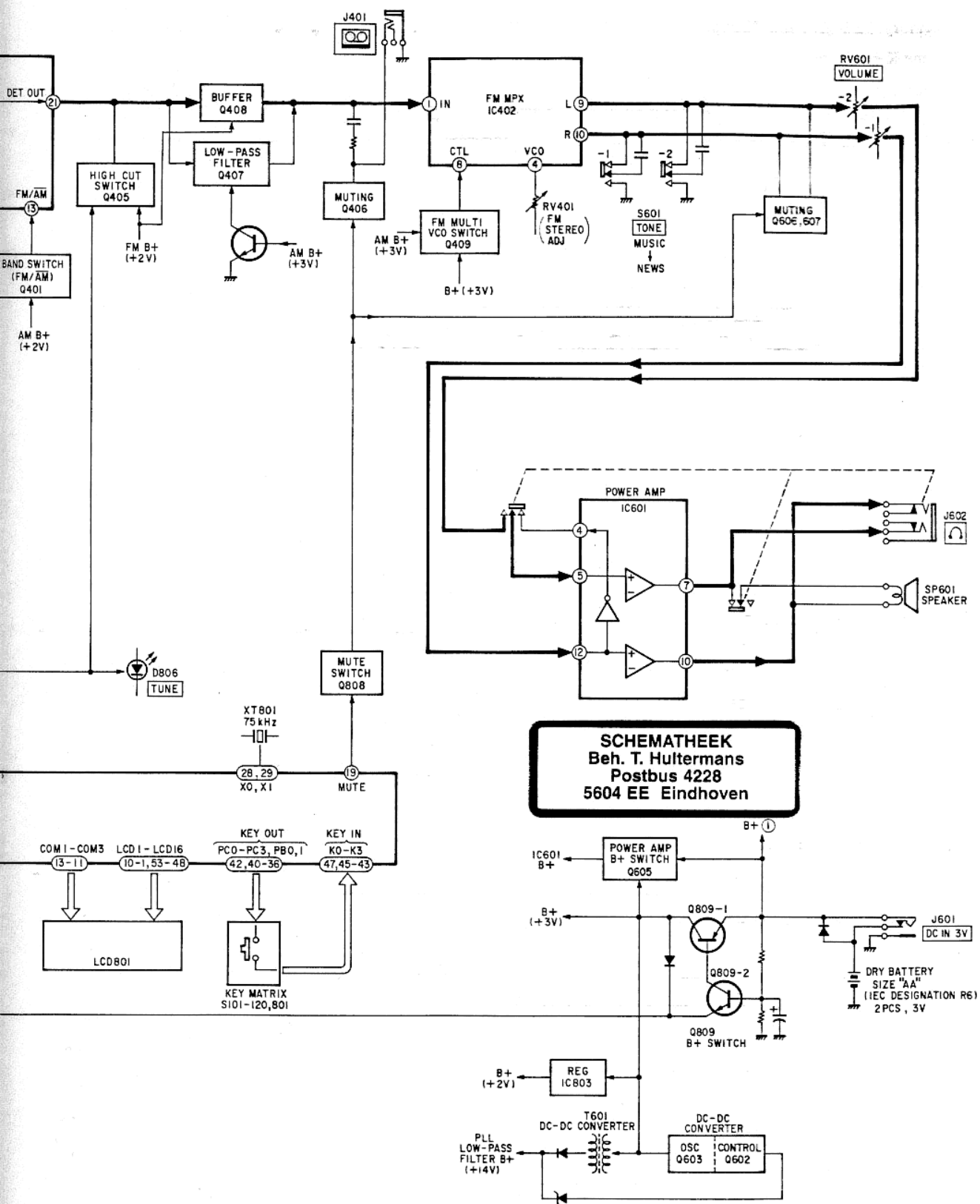

SCHEMATHEEK
Beh. T. Hultermans
Postbus 4228
5604 EE Eindhoven

● Semiconductor Location

Ref. No.	Location	Ref. No.	Location	Ref. No.	Location
D1	D-13	D813	J-24	Q409	B-21
D2	D-13			Q410	C-18
D3	B-13	IC401	C-6	Q411	C-18
D4	B-14	IC402	B-3	Q412	C-17
D5	B-13	IC601	D-3	Q413	B-2
D6	B-9	IC801	I-5	Q420	C-7
D7	B-9	IC802	H-4	Q602	E-19
D8	D-13	IC803	I-3	Q603	D-19
D203	D-16	IC804	H-1	Q605	E-21
D204	B-19			Q606	B-2
D401	B-17	Q1	C-10	Q607	B-2
D402	D-17	Q2	B-14	Q801	J-4
D403	D-17	Q3	C-8	Q802	J-4
D601	C-4	Q4	B-15	Q804	G-2
D602	D-4	Q5	B-6	Q805	I-2
D604	E-19	Q6	B-5	Q806	I-1
D801	J-4	Q7	C-5	Q807	I-1
D802	J-6	Q201	E-8	Q808	J-3
D803	I-24	Q202	C-8	Q809	H-3
D804	I-24	Q203	B-4	Q811	I-1
D805	I-24	Q205	E-7	Q812	I-2
D806	G-22	Q401	C-18	Q813	J-1
D807	G-1	Q402	D-17	Q814	J-1
D808	H-2	Q403	C-17	Q815	I-1
D809	I-2	Q405	D-5	Q816	I-4
D810	I-2	Q406	C-20	Q817	J-3
D811	I-4	Q407	C-3	Q818	J-4
D812	I-3	Q408	C-3		

Note:

- Color code or sleeving over the end of the jacket.

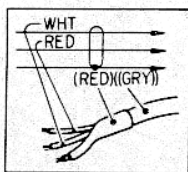

- : parts extracted from the component side.
- : parts extracted from the conductor side.
- ⊗ : Through hole.
- ⊙ : Pattern on the side which is seen.
- ⊗ ⊙ : Through hole to SIDE A and SIDE B indicate to jointed number and connection.
- ⊙ : SIDE A and SIDE B indicate to jointed number and connection.
- : parts mounted on the conductor side.

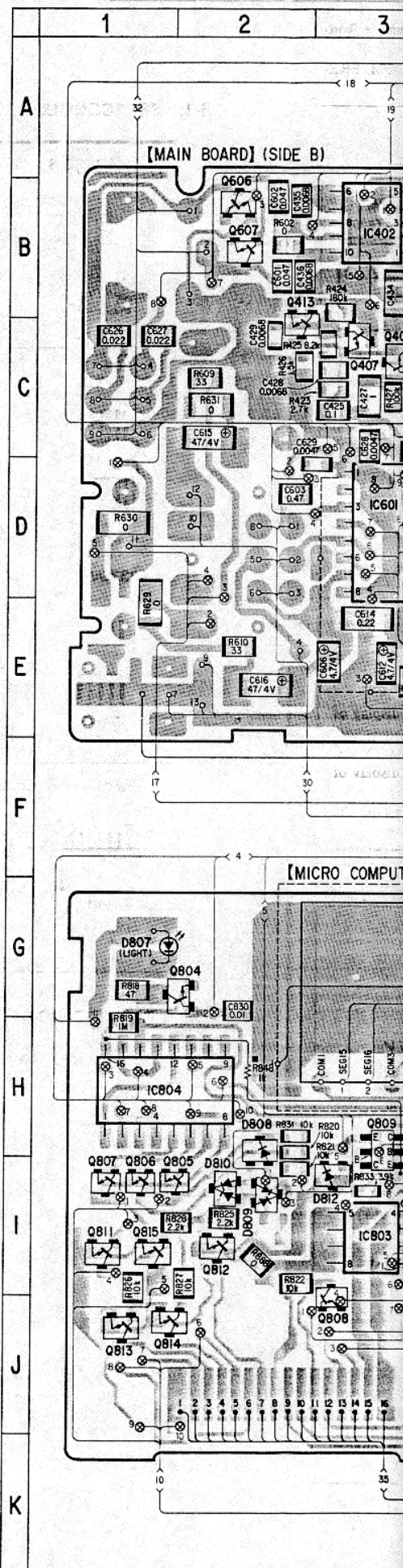

ICF-2W1
 • See page 20 for semiconductor lead layouts

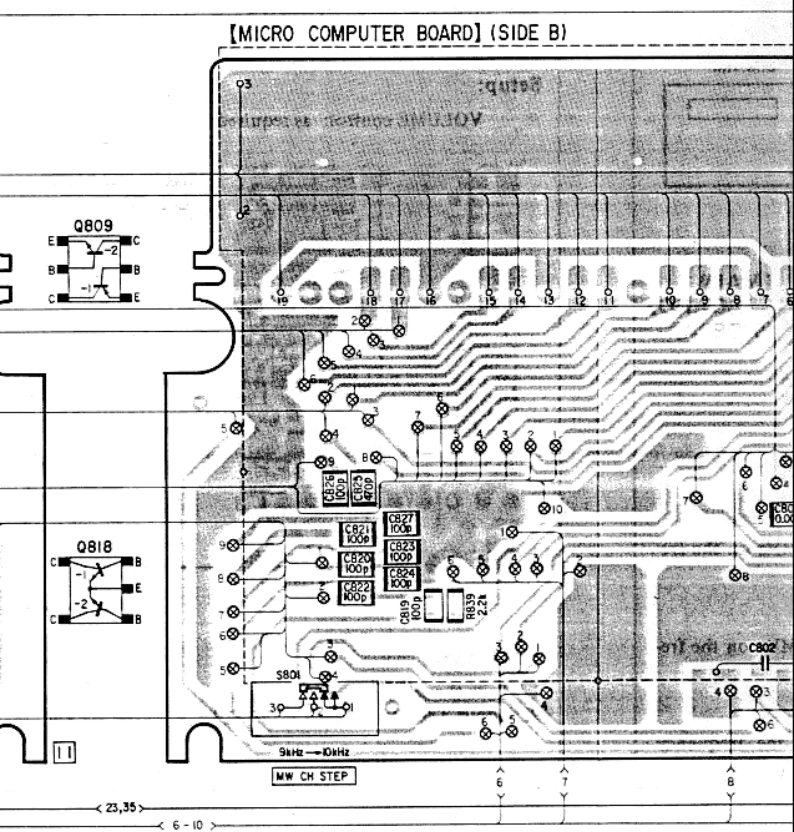
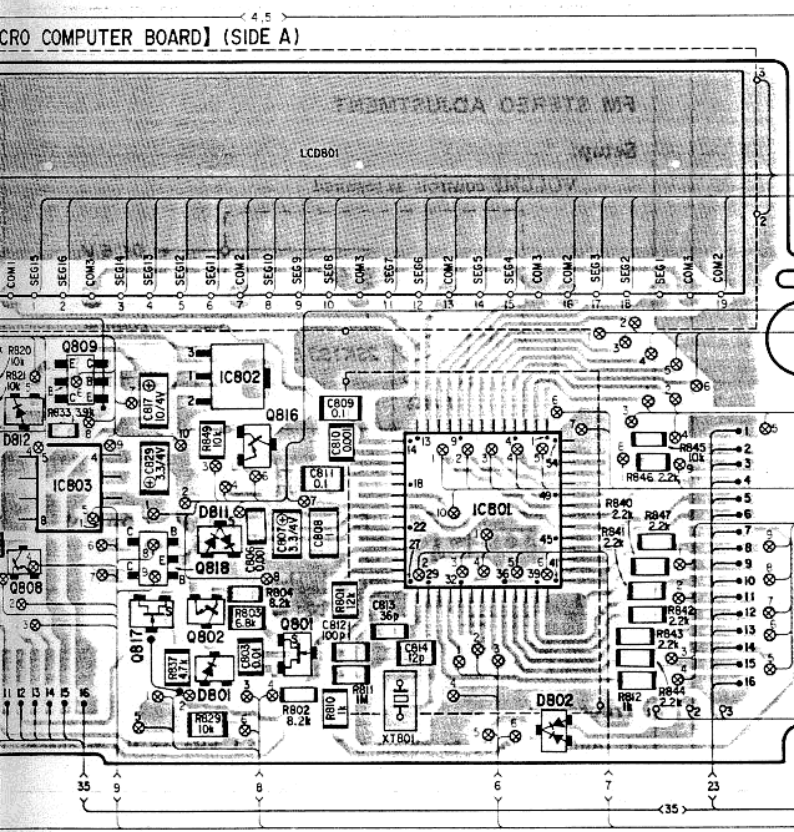
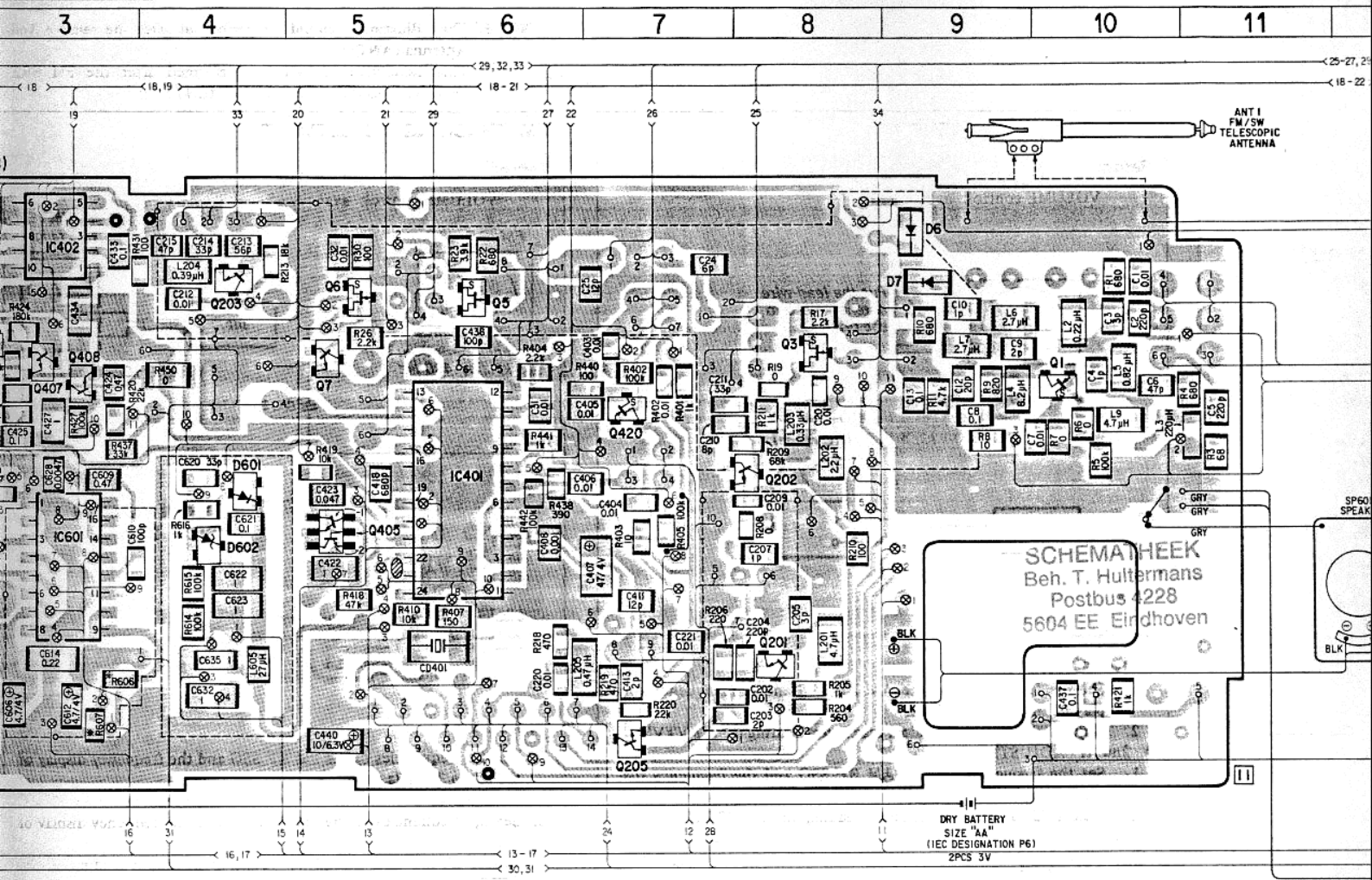

11 12 13 14 15 16 17 18 19

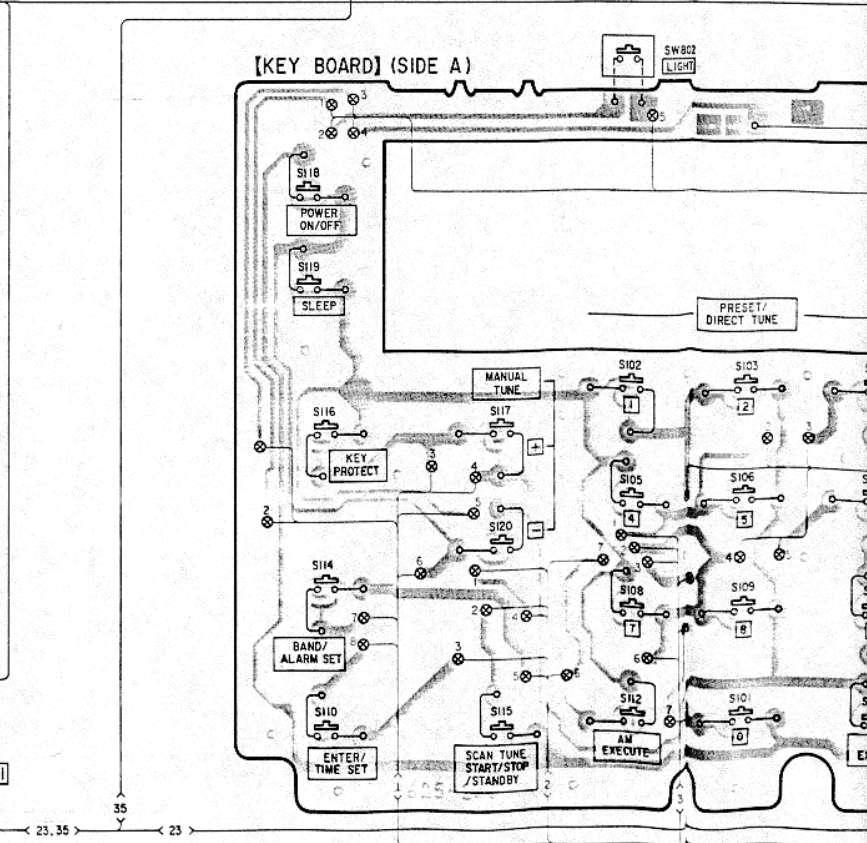
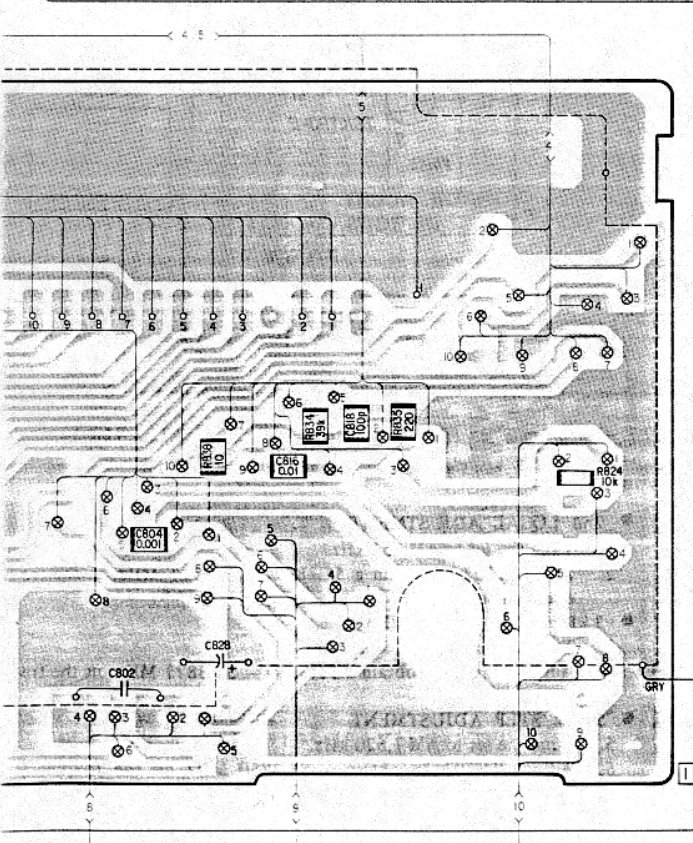
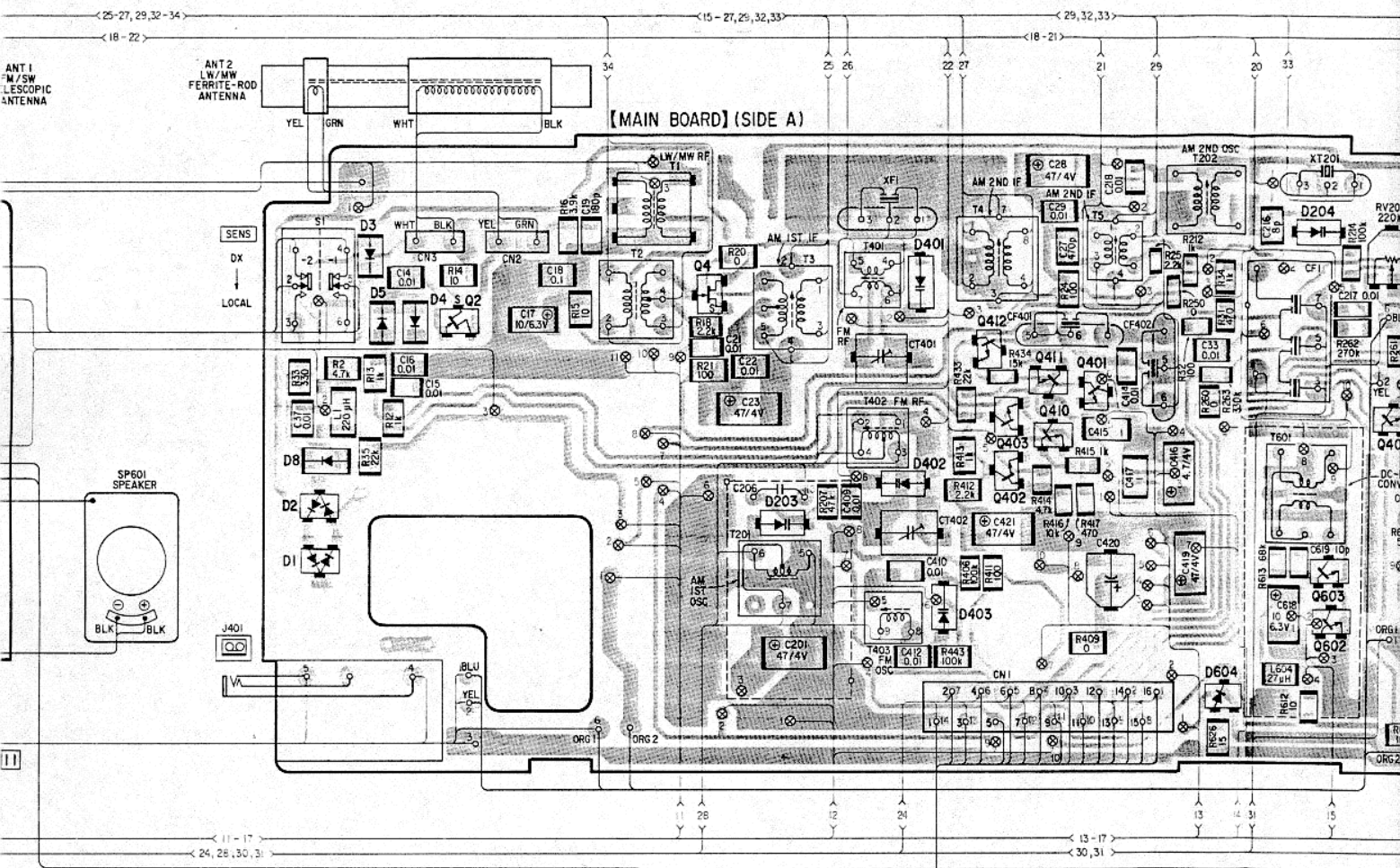

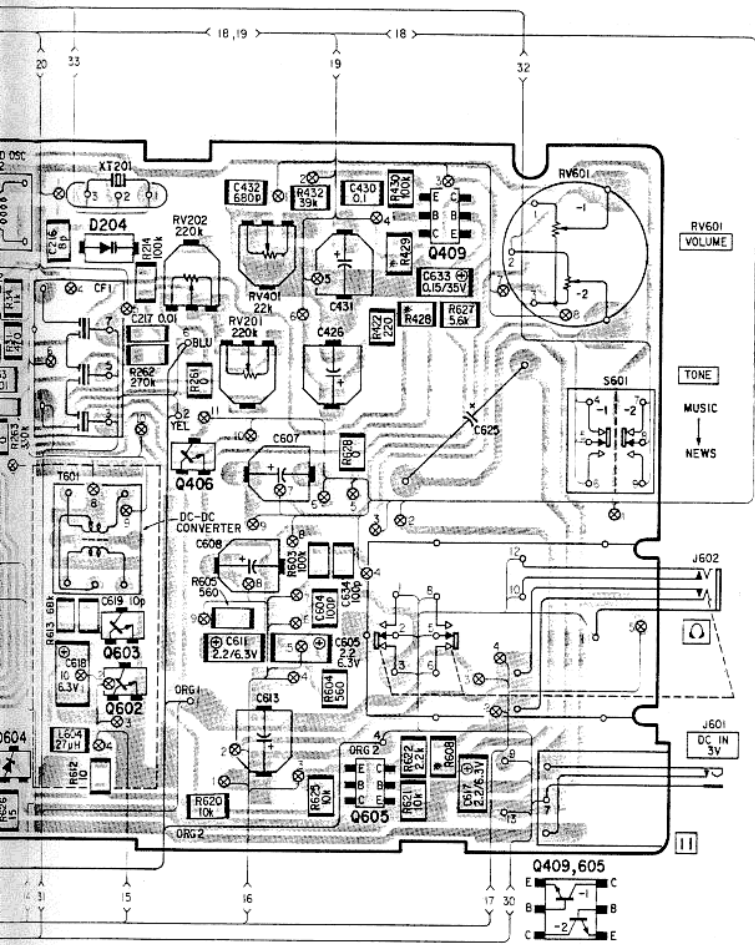

● Circuit Boards Location

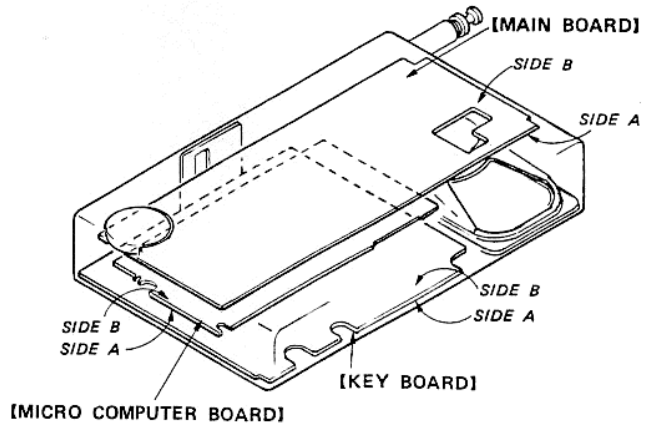

It is needed to replace all those parts marked * at the same time in case when necessary replacement for one of them.
 ●印の部品で以下に記した部品を交換する場合は同時に部品交換が必要です。

REF. NO.	OLD	NEW
R428	220k	100k
R429	100k	47k
R606	10k	4.7k
R607	10k	4.7k
R608	100k	56k

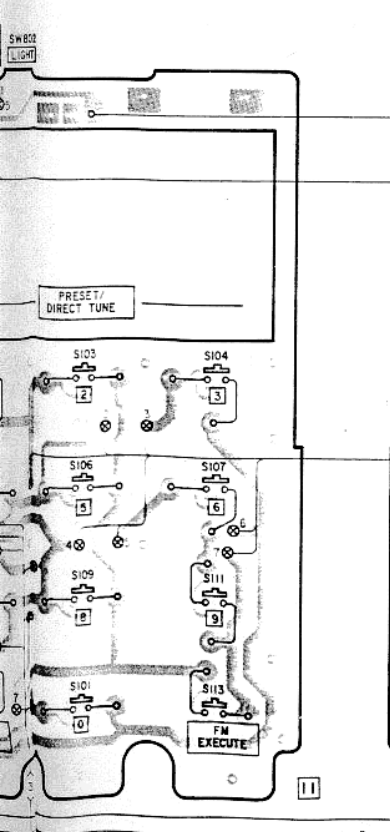

【KEY BOARD】(SIDE B)

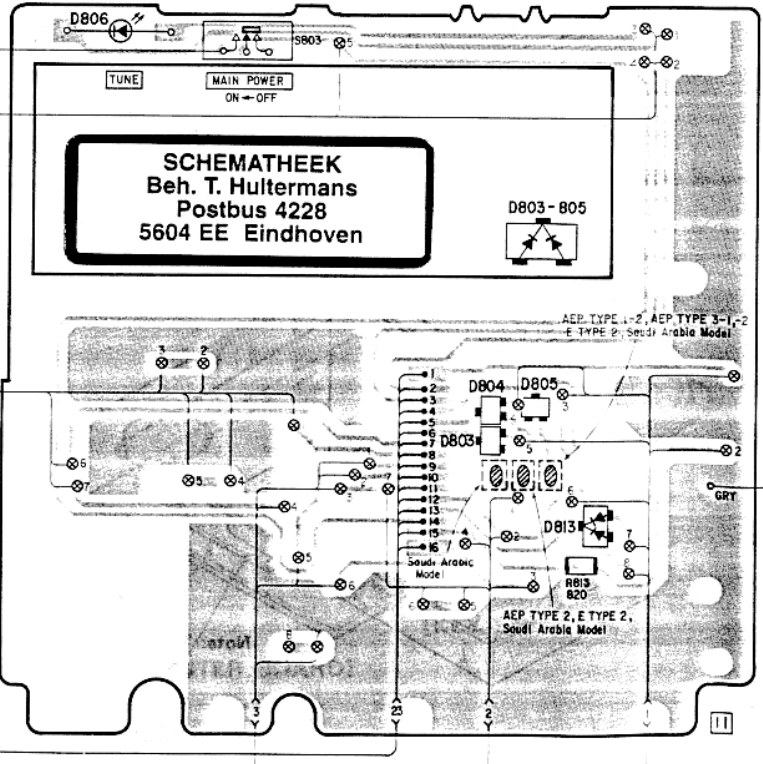

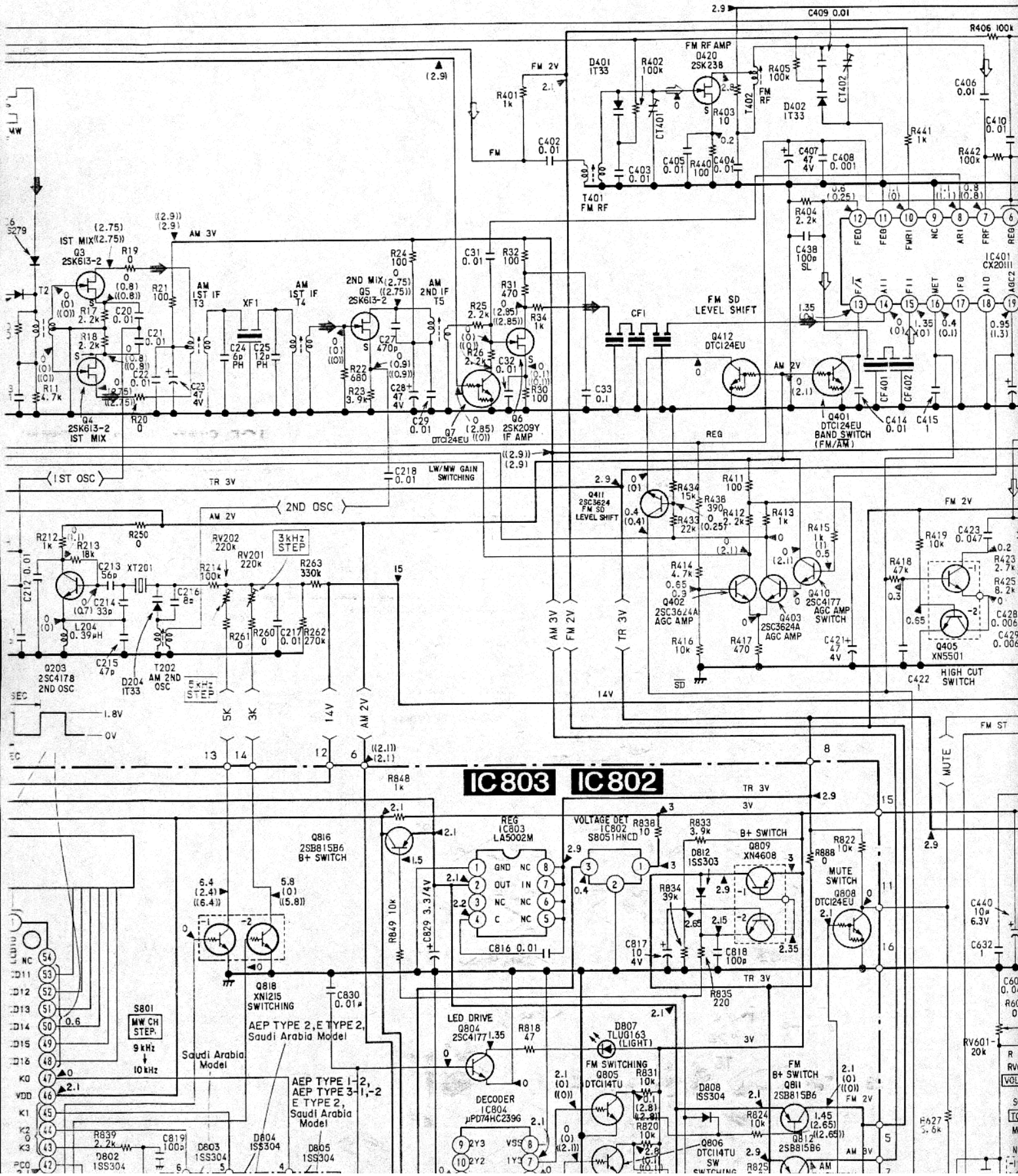

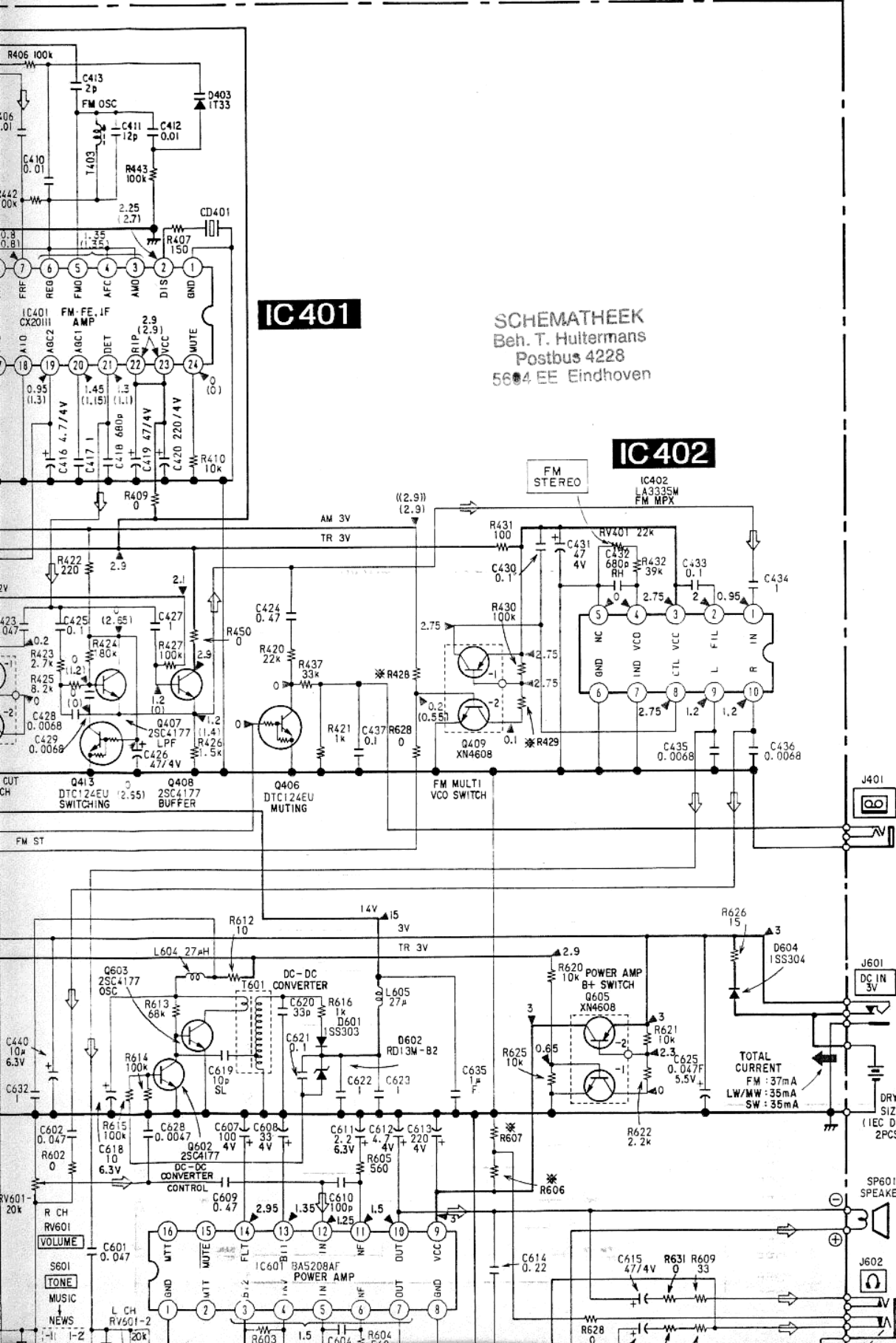

IC 401

SCHEMATHEEK
Beh. T. Huitemans
Postbus 4228
5604 EE Eindhoven

IC 402

IC402
LA3335W
FM MPX

AM 3V
TR 3V

FM STEREO

Q407
2SC4177

Q409
XN4608

Q406
DTC124EU

Q408
2SC4177

Q603
2SC4177

Q602
RD13M-B2

Q605
XN4608

D601
1SS303

D602
RD13M-B2

D604
1SS304

D602
RD13M-B2

DC-DC
CONVERTER
CONTROL

DC-DC
CONVERTER

DC-DC
CONVERTER

DC-DC
CONVERTER

POWER AMP
B+ SWITCH

TOTAL CURRENT
FM : 37mA
LW/MW : 35mA
SW : 35mA

DRY BATTERY
SIZE "AA"
(IEC DESIGNATION R6)
2PCS, 3V

SP601
SPEAKER

J601
DC IN
3V

J602

J601

J602

J601

J601

J602

J601

J602

J601

J602

J601

J602

J601

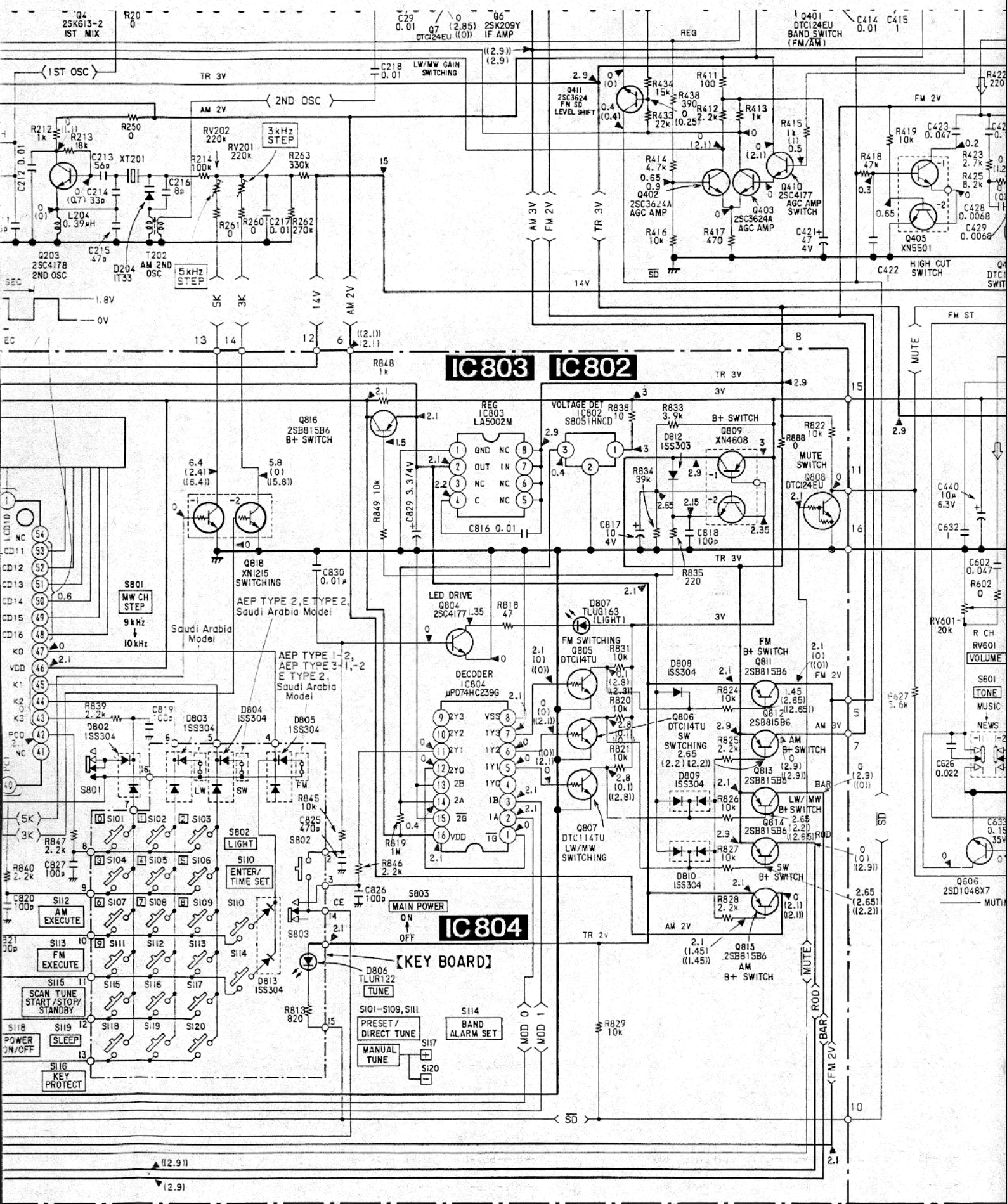

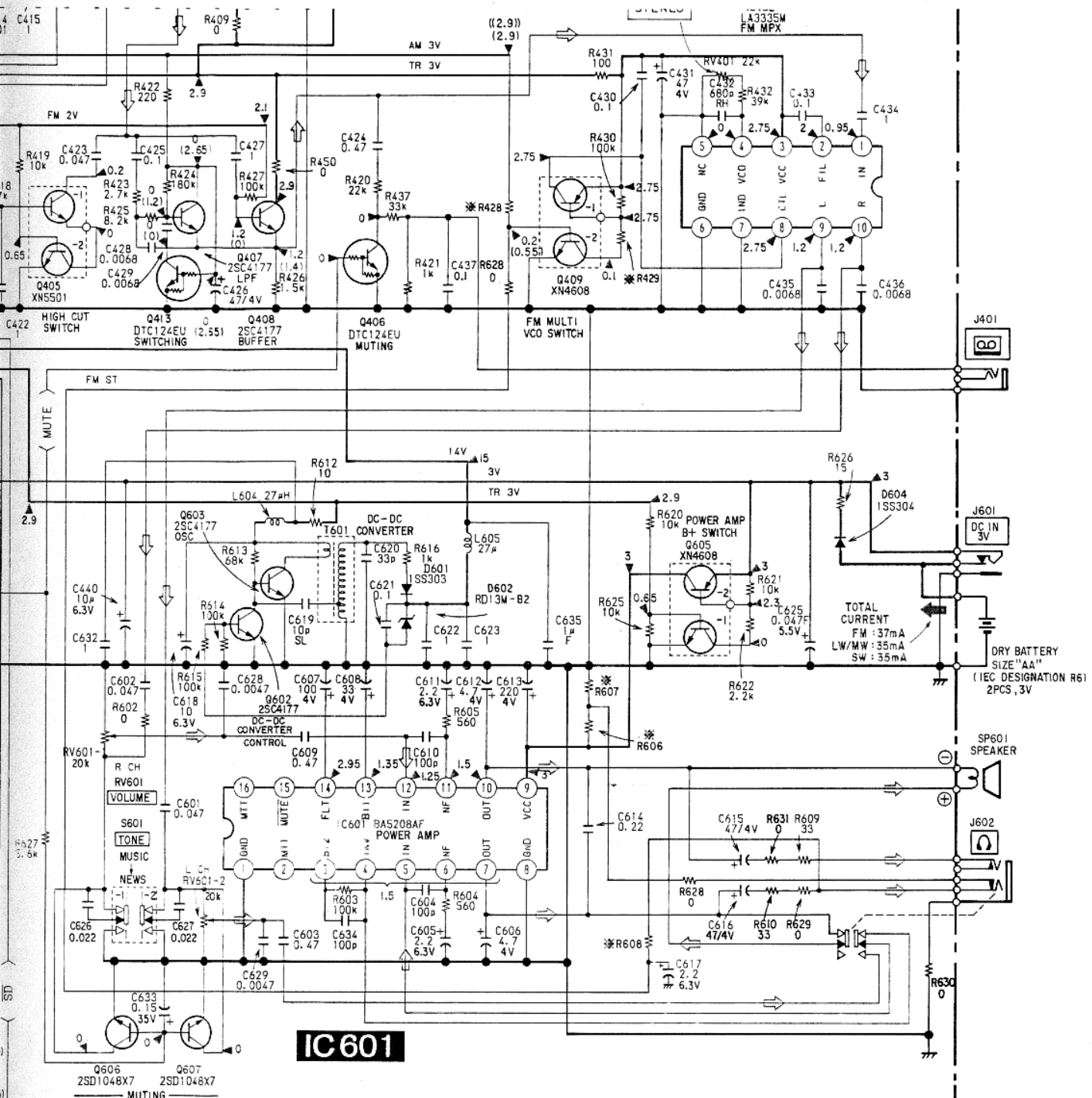

SCHEMATHEEK
 Beh. T. Hultermans
 Postbus 4228
 5604 EE Eindhoven

It is needed to replace all those parts marked * at the same time in case when necessary replacement for one of them.
 *印の部品で以下に記した部品を交換する場合は同時に部品交換が必要です。

REF NO.	OLD	NEW
R428	220k	100k
R429	100k	47k
R606	10k	4.7k
R607	10k	4.7k
R608	100k	56k

D
E
F
G
H
I
J
K
L
M
N
O

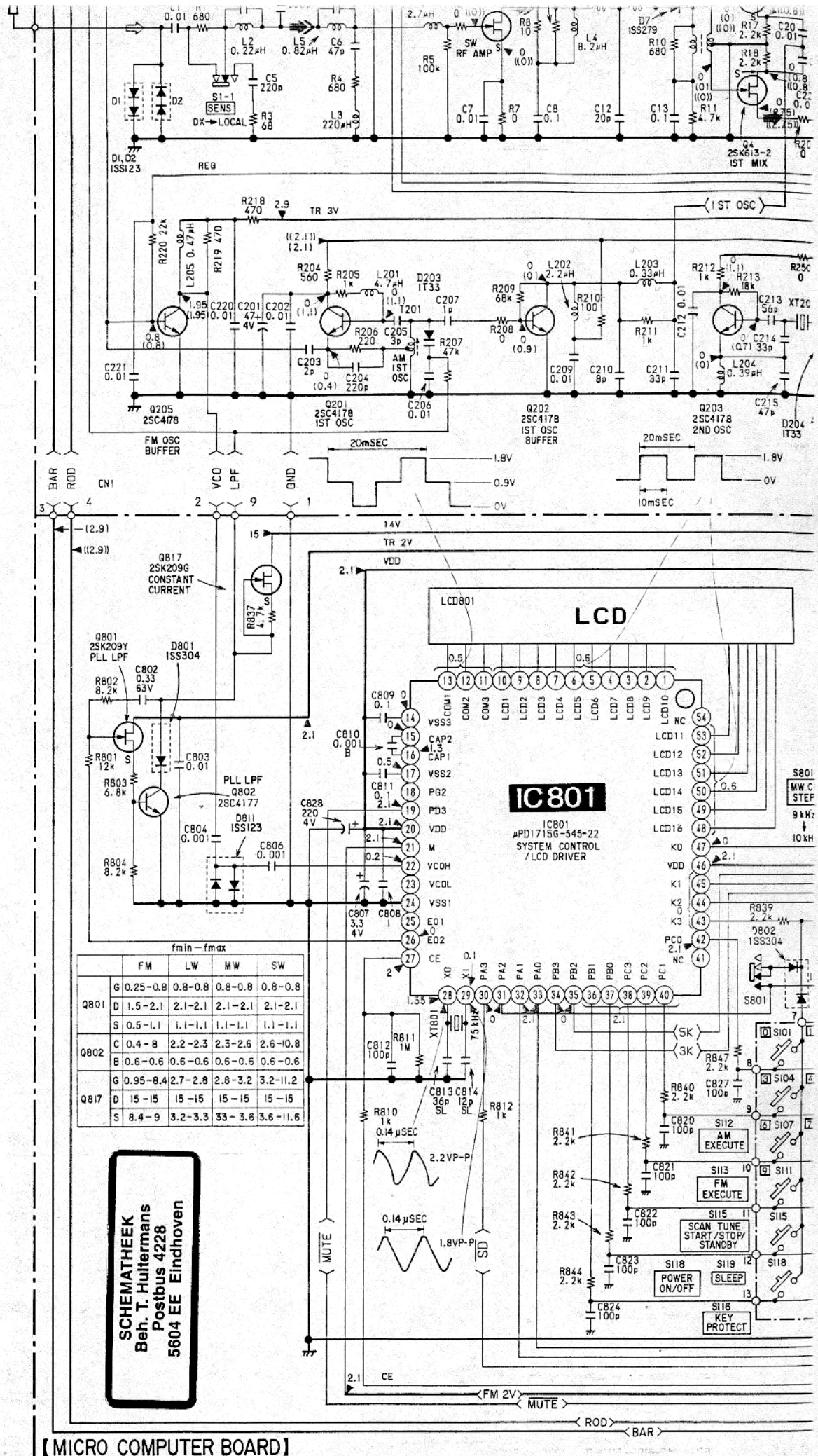

	FM	LW	MW	SW
Q801	G 0.25-0.8	0.8-0.8	0.8-0.8	0.8-0.8
	D 1.5-2.1	2.1-2.1	2.1-2.1	2.1-2.1
	S 0.5-1.1	1.1-1.1	1.1-1.1	1.1-1.1
Q802	C 0.4-8	2.2-2.3	2.3-2.6	2.6-10.8
	B 0.6-0.6	0.6-0.6	0.6-0.6	0.6-0.6
Q817	G 0.95-8.4	2.7-2.8	2.8-3.2	3.2-11.2
	D 15-15	15-15	15-15	15-15
	S 8.4-9	3.2-3.3	3.3-3.6	3.6-11.6

SCHEMATHEEK
Beh. T. Hultermans
Postbus 4228
5604 EE Eindhoven

【 MICRO COMPUTER BOARD 】

6-4. SCHEMATIC DIAGRAM

- See page 14 for liquid-crystal panel (LCD801)
- See page 28 for note and IC block diagrams

A
B
C
D
E
F
G
H
I
J
K

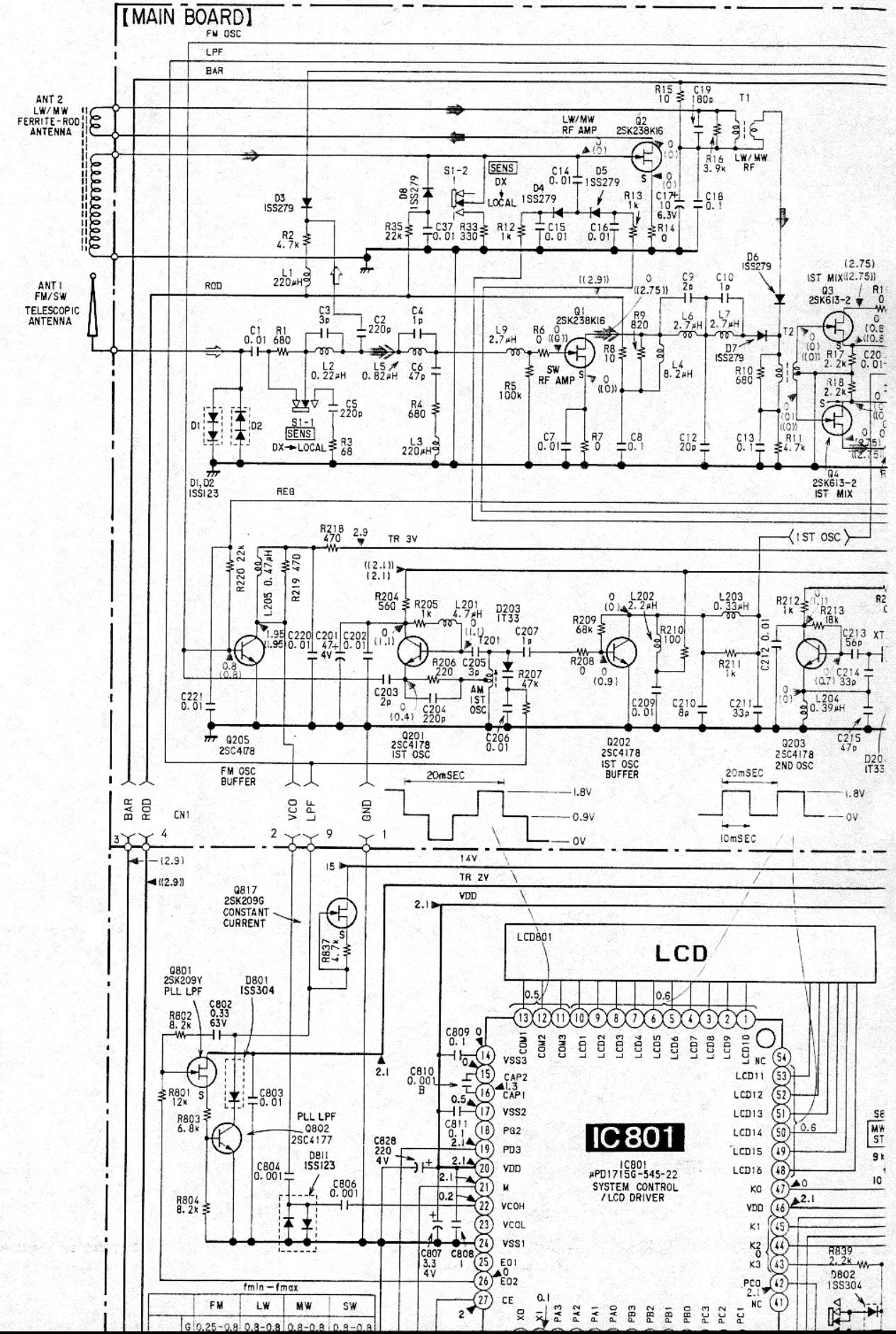

IC801

IC801
#PD17156-545-22
SYSTEM CONTROL
/LCD DRIVER

LCD801

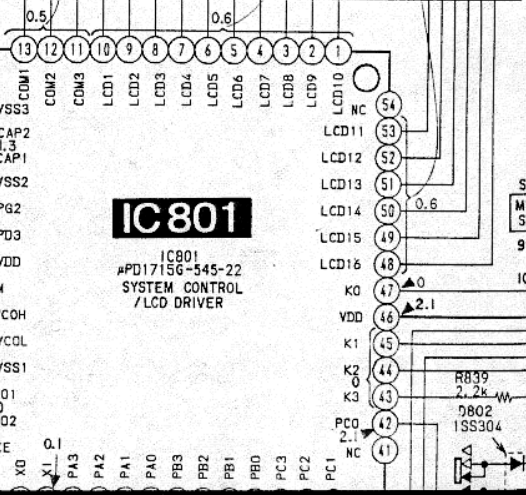

ICF-SW1
AN-101

Note:

- All capacitors are in μF unless otherwise noted, pF: μpF 50WV or less are not indicated except for electrolytics and tantalums.
- All resistors are in Ω and $1/4\text{W}$ or less unless otherwise specified.
- Δ : internal component.
- --- : B+ bus.
- \square : adjustment for repair.
- Power voltage is dc 3 V and fed with regulated dc power supply from external power voltage jack.
- Voltage and waveforms are dc with respect to ground under detuned conditions.
- no mark: FM
() : SW
() : LW/MW
- Voltages are taken with a VOM (50 k Ω /V). Voltage variations may be noted due to normal production tolerances.
- Waveforms are taken with an oscilloscope. Voltage variations may be noted due to normal production tolerances.
- Signal path.
◁ : FM
➡ : LW/MW
➤ : SW
- Switches:

Ref. No.	Switch	Position
S1	SENS	DX
S101	0	OFF
S102	1	OFF
S103	2	OFF
S104	3	OFF
S105	4	OFF
S106	5	OFF
S107	6	OFF
S108	7	OFF
S109	8	OFF
S110	ENTER/TIME SET	OFF
S111	9	OFF
S112	AM EXECUTE	OFF
S113	FM EXECUTE	OFF
S114	BAND ALARM SET	OFF
S115	SCAN TUNE	OFF
S116	KEY PROJECT	OFF
S117	+	OFF
S118	POWER	OFF
S119	SLEEP	OFF
S120	-	OFF
S601	TONE	MUSIC
S801	MW CH STEP	9 kHz
S802	LIGHT	OFF
S803	MAIN POWER	OFF

IC601 BA5208AF

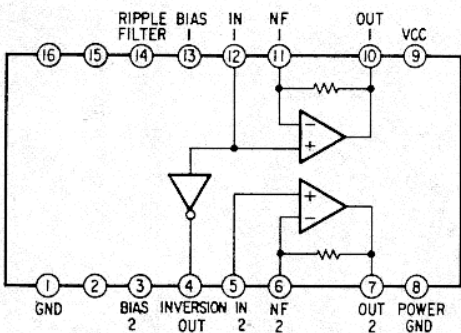

6.5. IC BLOCK DIAGRAM

IC401 CX20111

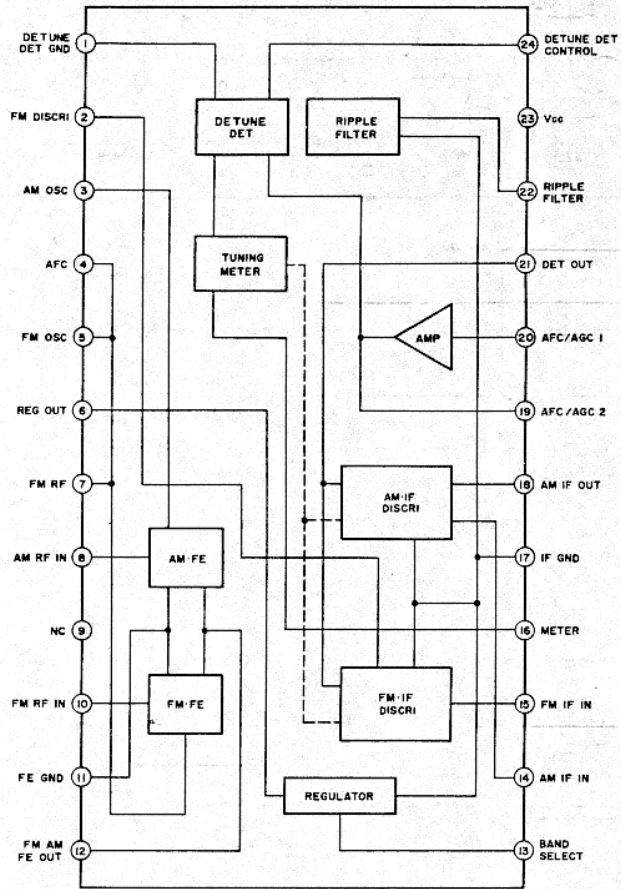

IC402 LA3335M

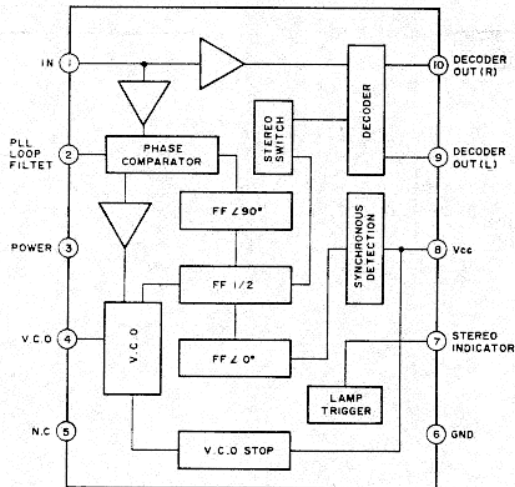

- No.
1
2
3
4
5
6
7
8
9
10
11
12
13
14

SECTION 7 EXPLODED VIEWS AND PARTS LIST

NOTE:

- The mechanical parts with no reference number in the exploded views are not supplied.
- Due to standardization, parts with part number suffix -XX and -X may be different from the parts specified in the components used on the set.
- The construction parts of an assembled part are indicated with a collation number in the remark column.
- Items marked "*" are not stocked since they are seldom required for routine service. Some delay should be anticipated when ordering these items.

7-1.

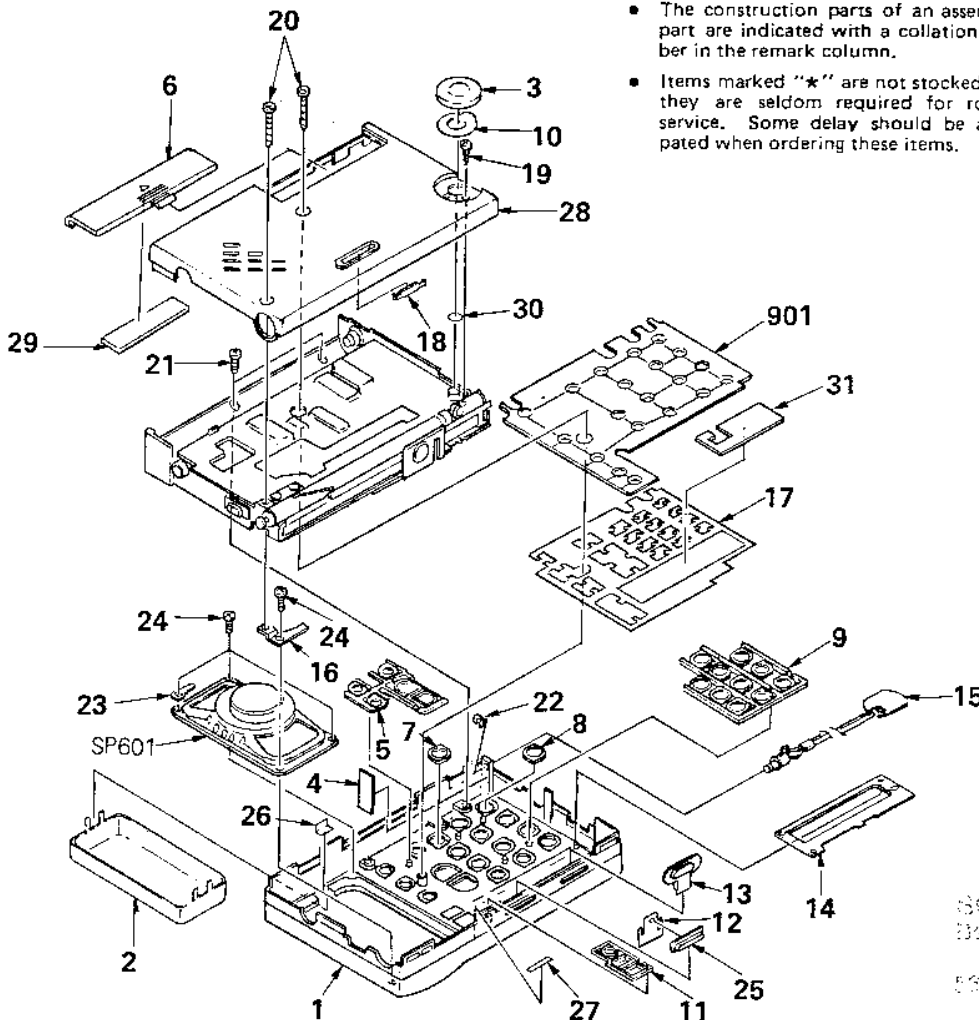

SCHEMATHEEK
Beh. F. Hultermans
Postbus 4228
5500 AE Eindhoven

Part No.	Description	Remarks	No.	Part No.	Description	Remarks	No.
X-3899-501-1	CABINET (FRONT) ASSY		15	X-3899-503-1	STRAP ASSY, HAND		
3-899-527-01	PANEL, SPEAKER		16	3-899-526-01	BRACKET		
3-899-506-01	KNOB (VOLUME)		17	3-899-548-01	SHEET (A), RETAINER		
*3-899-575-01	SHEET (STRAP)		18	3-899-533-01	HOLDER		51
3-899-549-01	BUTTON (DOUBLE)		19	7-685-104-19	SCREW (B 2X6), P TAPPING		52
3-899-535-01	LID, BATTERY CASE		20	7-621-256-00	SCREW +P 2X16		53
3-899-561-01	BUTTON (10 KEY)		21	2-370-905-31	SCREW +PTP 2X3.5		54
3-899-560-01	BUTTON (10 KEY)		22	7-624-102-04	STOP RING 1.5, TYPE -E		55
3-899-551-01	BUTTON (10 KEY)		23	7-623-505-01	LUG, 2		56
*3-899-570-01	SHEET (VR)		24	7-627-554-58	SCREW +P 2X2.8		57
3-899-550-01	BUTTON (POWER)		25	3-899-510-01	(US,Canadian,Australian E TYPE1-2/2,Saudi Arabia AEP TYPE1-1/1-2/2/3-1/3-2,UK) ...BUTTON (LIGHT)		58
3-899-534-01	SHEET (B), RETAINER			3-899-510-11	(E TYPE1-1).....BUTTON (LIGHT)		59
3-899-511-01	KNOB (MAIN POWER)						60
3-899-531-01	(US,Canadian,Australian E TYPE1-1/1-2 AEP TYPE1-1/1-2,UK)....PLATE, BACK		26	*3-899-577-01	COPPER LEAF (A)		61
3-899-531-11	(AEP TYPE3-1/3-2).....PLATE, BACK		27	*3-899-581-01	COPPER LEAF (B)		62
3-899-531-21	(E TYPE2,AEP TYPE2)....PLATE, BACK		28	3-899-558-11	CABINET (REAR)		63
3-899-531-31	(Saudi Arabia).....PLATE, BACK		29	9-911-815-01	CUSHION		64
			30	*3-899-589-01	SHEET (SHAFT)		65
			31	3-899-573-01	MEMBRANE, CONDUCTIVE		66
			901	1-571-386-11	SWITCH, RUBBER KEY (S101-S120)		67
			SP601	1-503-842-11	SPEAKER		68
							69
							70

7-2.

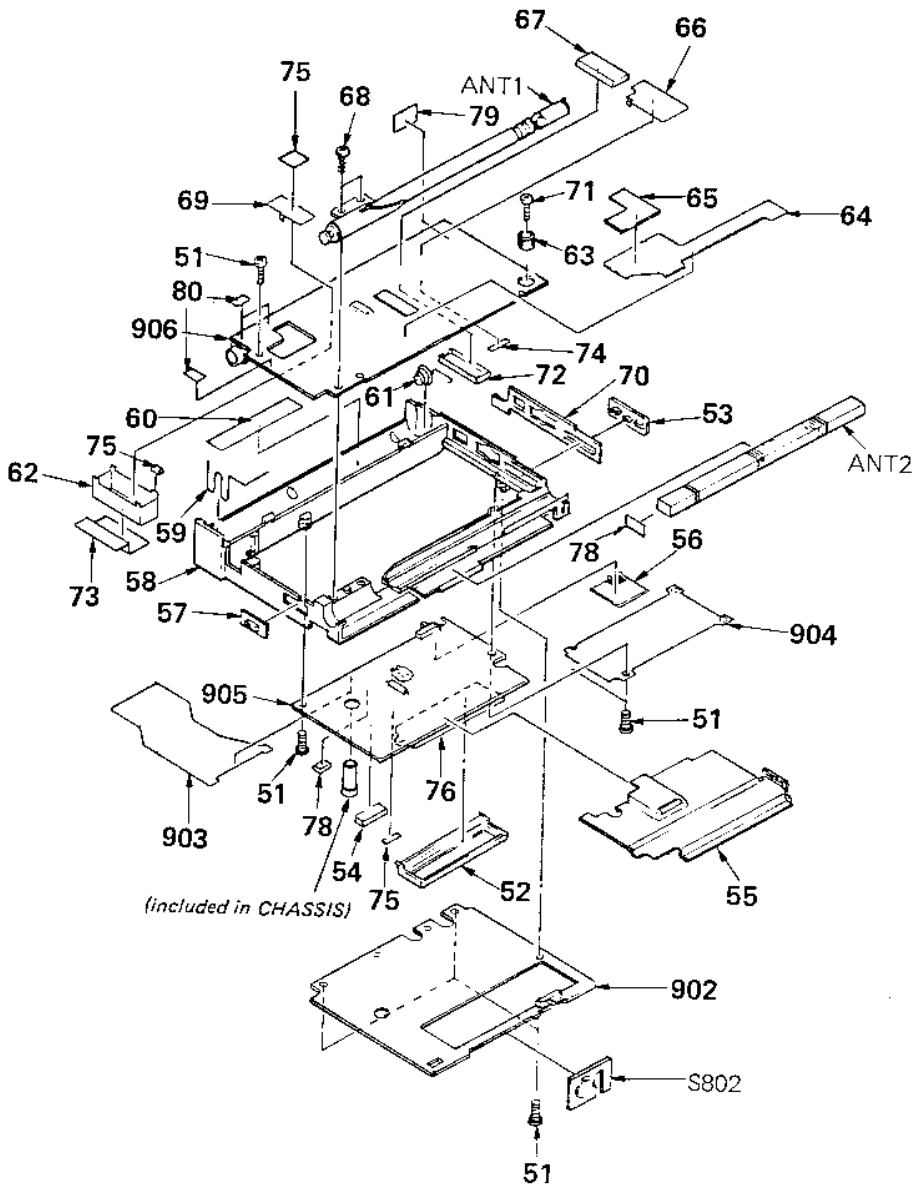

No.	Part No.	Description
51	7-621-256-00	SCREW +P 2X16
52	*3-899-530-01	CASE, SHIELD
53	3-899-509-01	KNOB (TONE)
54	9-911-844-XX	RUBBER, BRAKE
55	*X-3899-502-1	PLATE (A) ASSY, SHIELD
56	*3-899-521-01	PLATE (CLOCK), SHIELD
57	3-899-508-01	KNOB
58	*3-899-559-01	CHASSIS
59	3-899-529-01	TERMINAL, BATTERY
60	*3-899-501-01	LABEL (MW STEP)
61	3-899-528-01	SPRING
62	*3-899-522-01	CASE (AM LOCAL), SHIELD
63	3-899-505-01	SHAFT
64	*X-3899-505-1	PLATE (IF) ASSY, SHIELD
65	*3-899-574-01	SHEET (SPEAKER)
66	*X-3899-506-1	PLATE (AF) ASSY, SHIELD
67	*3-899-523-01	CASE, SHIELD
68	7-685-104-19	SCREW (B 2X6), P TAPPING
69	*X-3899-504-1	PLATE (VCO) ASSY, SHIELD
70	*3-899-525-01	REINFORCEMENT

No.	Part No.	Description	Remarks
71	7-627-850-67	SCREW, PRECISION +P 1.4X4	
72	*3-899-524-01	CASE, SHIELD	
73	*3-899-576-01	SHEET (VCO)	
74	*3-899-577-01	COPPER LEAF (A)	
75	*3-899-582-01	INSULATOR (E)	
76	*3-899-507-01	PLATE, LIGHT GUIDE	
78	9-911-844-XX	RUBBER, BRAKE	
79	*3-339-464-01	CUSHION (LED)	
80	*3-899-586-01	SPACER (A)	
902	A-3679-087-A	MOUNTED PCB, KEY	
903	1-625-372-11	PC BOARD, MICON FLEXIBLE	
904	1-625-371-11	PC BOARD, MA FLEXIBLE	
905	A-3675-007-A	MOUNTED PCB, MICRO COMPUTER	
906	A-3615-207-A	MOUNTED PCB, MAIN	
ANT1	1-501-401-11	ANTENNA, TELESCOPIC	
ANT2	1-402-344-11	ANTENNA, FERRITE-ROD (LW/MW)	
S802	1-571-385-11	SWITCH, KEY BOARD (LIGHT)	

SECTION 8 ELECTRICAL PARTS LIST

NOTE:

- Due to standardization, replacements in the parts list may be different from the parts specified in the diagrams or the components used on the set.
- Items marked "*" are not stocked since they are seldom required for routine service. Some delay should be anticipated when ordering these items.
- If there are two or more same circuits in a set such as a stereophonic machine, only typical circuit parts may be indicated and capacitors and resistors in other same circuits may be omitted.

CAPACITORS:

MF: μ F, PF: μ F.

RESISTORS

- All resistors are in ohms.
- F: nonflammable

COILS

- MMH: mH, UH: μ H

SEMICONDUCTORS

In each case, U: μ , for example:

UA...: μ A..., UPA...: μ PA...,
UPC...: μ PC, UPD...: μ PD...

The components identified by mark Δ are critical for safety. Replace only with part number specified.

Les composants identifiés par une marque Δ sont critiques pour la sécurité. Ne les remplacer que par une pièce portant le numéro spécifié.

Ref.No.	Part No.	Description							
901	1-571-386-11	SWITCH, RUBBER KEY (S101-S120)							
902	A-3679-087-A	MOUNTED PCB, KEY							
903	1-625-372-11	PC BOARD, MICON FLEXIBLE							
904	1-625-371-11	PC BOARD, MA FLEXIBLE							
905	A-3675-007-A	MOUNTED PCB, MICRO COMPUTER							
906	A-3615-207-A	MOUNTED PCB, MAIN							
907	1-501-400-11	ANTENNA, TELESCOPIC							
ANT1	1-501-401-11	ANTENNA, TELESCOPIC							
ANT2	1-402-344-11	ANTENNA, FERRITE-ROD (LW/MW)							
C1	1-162-970-11	CERAMIC CHIP 0.01MF	10%	25V					
C2	1-162-957-11	CERAMIC CHIP 220PF	5%	50V					
C3	1-162-934-11	CERAMIC CHIP 3PF	0.25PF	50V					
C4	1-162-930-11	CERAMIC CHIP 1PF	0.25PF	50V					
C5	1-162-957-11	CERAMIC CHIP 220PF	5%	50V					
C6	1-162-949-11	CERAMIC CHIP 47PF	5%	50V					
C7	1-162-970-11	CERAMIC CHIP 0.01MF	10%	25V					
C8	1-164-004-11	CERAMIC CHIP 0.1MF	10%	25V					
C9	1-162-932-11	CERAMIC CHIP 2PF	0.25PF	50V					
C10	1-162-930-11	CERAMIC CHIP 1PF	0.25PF	50V					
C12	1-164-113-11	CERAMIC CHIP 20PF	5%	50V					
C13	1-164-004-11	CERAMIC CHIP 0.1MF	10%	25V					
C14	1-162-970-11	CERAMIC CHIP 0.01MF	10%	25V					
C15	1-162-970-11	CERAMIC CHIP 0.01MF	10%	25V					
C16	1-162-970-11	CERAMIC CHIP 0.01MF	10%	25V					
C17	1-135-157-21	TANTAL. CHIP 10MF	20%	6.3V					
C18	1-164-004-11	CERAMIC CHIP 0.1MF	10%	25V					
C19	1-162-956-11	CERAMIC CHIP 180PF	5%	50V					
C20	1-162-970-11	CERAMIC CHIP 0.01MF	10%	25V					
C21	1-162-970-11	CERAMIC CHIP 0.01MF	10%	25V					
C22	1-162-970-11	CERAMIC CHIP 0.01MF	10%	25V					
C23	1-135-098-21	TANTAL. CHIP 47MF	20%	4V					
C24	1-163-089-00	CERAMIC CHIP 6PF	0.25PF	50V					
C25	1-163-095-00	CERAMIC CHIP 12PF	5%	50V					
C27	1-163-133-00	CERAMIC CHIP 470PF	5%	50V					
C28	1-135-098-21	TANTAL. CHIP 47MF	20%	4V					
C29	1-162-970-11	CERAMIC CHIP 0.01MF	10%	25V					
C31	1-163-021-00	CERAMIC CHIP 0.01MF	10%	50V					
C32	1-162-970-11	CERAMIC CHIP 0.01MF	10%	25V					
C33	1-162-970-11	CERAMIC CHIP 0.01MF	10%	25V					
C37	1-162-970-11	CERAMIC CHIP 0.01MF	10%	25V					
C201	1-135-098-21	TANTAL. CHIP 47MF	20%	4V					
C202	1-162-970-11	CERAMIC CHIP 0.01MF	10%	25V					
C203	1-162-932-11	CERAMIC CHIP 2PF	0.25PF	50V					
C204	1-162-957-11	CERAMIC CHIP 220PF	5%	50V					
C205	1-162-934-11	CERAMIC CHIP 3PF	0.25PF	50V					
C206	1-162-839-11	CERAMIC	0.01MF	20%	16V				
C207	1-162-930-11	CERAMIC CHIP	1PF	0.25PF	50V				
C209	1-162-970-11	CERAMIC CHIP	0.01MF	10%	25V				
C210	1-162-939-11	CERAMIC CHIP	8PF	0.5PF	50V				
C211	1-162-947-11	CERAMIC CHIP	33PF	5%	50V				
C212	1-162-970-11	CERAMIC CHIP	0.01MF	10%	25V				
C213	1-162-950-11	CERAMIC CHIP	56PF	5%	50V				
C214	1-162-947-11	CERAMIC CHIP	33PF	5%	50V				
C215	1-163-598-91	CERAMIC CHIP	47PF	5%	50V				
C216	1-162-939-11	CERAMIC CHIP	8PF	0.5PF	50V				
C217	1-162-970-11	CERAMIC CHIP	0.01MF	10%	25V				
C218	1-162-970-11	CERAMIC CHIP	0.01MF	10%	25V				
C220	1-162-970-11	CERAMIC CHIP	0.01MF	10%	25V				
C221	1-163-021-00	CERAMIC CHIP	0.01MF	10%	50V				
C402	1-162-970-11	CERAMIC CHIP	0.01MF	10%	25V				
C403	1-162-970-11	CERAMIC CHIP	0.01MF	10%	25V				
C404	1-162-970-11	CERAMIC CHIP	0.01MF	10%	25V				
C405	1-162-970-11	CERAMIC CHIP	0.01MF	10%	25V				
C406	1-162-970-11	CERAMIC CHIP	0.01MF	10%	25V				
C407	1-135-098-21	TANTAL. CHIP	47MF	20%	4V				
C408	1-163-141-00	CERAMIC CHIP	0.001MF	5%	50V				
C409	1-162-970-11	CERAMIC CHIP	0.01MF	10%	25V				
C410	1-162-970-11	CERAMIC CHIP	0.01MF	10%	25V				
C411	1-162-942-11	CERAMIC CHIP	12PF	5%	50V				
C412	1-162-970-11	CERAMIC CHIP	0.01MF	10%	25V				
C413	1-162-932-11	CERAMIC CHIP	2PF	0.25PF	50V				
C414	1-162-970-11	CERAMIC CHIP	0.01MF	10%	25V				
C415	1-162-638-11	CERAMIC CHIP	1MF		16V				
C416	1-135-151-21	TANTAL. CHIP	4.7MF	20%	4V				
C417	1-162-638-11	CERAMIC CHIP	1MF		16V				
C418	1-162-963-11	CERAMIC CHIP	680PF	10%	50V				
C419	1-135-098-21	TANTAL. CHIP	47MF	20%	4V				
C420	1-126-210-11	ELECT	220MF	20%	4V				
C421	1-135-098-21	TANTAL. CHIP	47MF	20%	4V				
C422	1-162-638-11	CERAMIC CHIP	1MF		16V				
C423	1-163-035-00	CERAMIC CHIP	0.047MF		50V				
C424	1-164-005-11	CERAMIC CHIP	0.47MF		25V				
C425	1-163-038-00	CERAMIC CHIP	0.1MF		25V				
C426	1-126-208-11	ELECT	47MF	20%	4V				
C427	1-162-638-11	CERAMIC CHIP	1MF		16V				
C428	1-162-969-11	CERAMIC CHIP	0.0068MF	10%	25V				
C429	1-162-969-11	CERAMIC CHIP	0.0068MF	10%	25V				
C430	1-163-038-00	CERAMIC CHIP	0.1MF		25V				
C431	1-126-208-11	ELECT	47MF	20%	4V				
C432	1-163-137-00	CERAMIC CHIP	680PF		50V				

Ref.No.	Part No.	Description			
C433	1-163-038-00	CERAMIC CHIP 0.1MF		25V	
C434	1-162-638-11	CERAMIC CHIP 1MF		16V	
C435	1-162-969-11	CERAMIC CHIP 0.0068MF	10%	25V	
C436	1-162-969-11	CERAMIC CHIP 0.0068MF	10%	25V	
C437	1-164-004-11	CERAMIC CHIP 0.1MF	10%	25V	
C438	1-163-117-00	CERAMIC CHIP 100PF	5%	50V	
C440	1-135-157-21	TANTAL. CHIP 10MF	20%	6.3V	
C601	1-163-035-00	CERAMIC CHIP 0.047MF	10%	25V	
C602	1-163-035-00	CERAMIC CHIP 0.047MF	10%	25V	
C603	1-164-005-11	CERAMIC CHIP 0.47MF	25V		
C604	1-162-953-11	CERAMIC CHIP 100PF	5%	50V	
C605	1-135-099-00	TANTAL. CHIP 2.2MF	20%	6.3V	
C606	1-135-151-21	TANTAL. CHIP 4.7MF	20%	4V	
C607	1-126-209-11	ELECT 100MF	20%	4V	
C608	1-126-207-11	ELECT 33MF	20%	4V	
C609	1-164-005-11	CERAMIC CHIP 0.47MF	25V		
C610	1-162-953-11	CERAMIC CHIP 100PF	5%	50V	
C611	1-135-099-00	TANTAL. CHIP 2.2MF	20%	6.3V	
C612	1-135-151-21	TANTAL. CHIP 4.7MF	20%	4V	
C613	1-126-210-11	ELECT 220MF	20%	4V	
C614	1-163-081-00	CERAMIC CHIP 0.22MF		25V	
C615	1-135-098-21	TANTAL. CHIP 47MF	20%	4V	
C616	1-135-098-21	TANTAL. CHIP 47MF	20%	4V	
C617	1-135-099-00	TANTAL. CHIP 2.2MF	20%	6.3V	
C618	1-135-157-21	TANTAL. CHIP 10MF	20%	6.3V	
C619	1-162-941-11	CERAMIC CHIP 10PF	0.5PF	50V	
C620	1-162-947-11	CERAMIC CHIP 33PF	5%	50V	
C621	1-163-038-00	CERAMIC CHIP 0.1MF	25V		
C622	1-162-638-11	CERAMIC CHIP 1MF		16V	
C623	1-162-638-11	CERAMIC CHIP 1MF		16V	
C625	1-125-513-11	DOUBLE LAYERS 0.047F		5.5V	
C626	1-163-033-00	CERAMIC CHIP 0.022MF	10%	25V	
C627	1-163-033-00	CERAMIC CHIP 0.022MF	10%	25V	
C628	1-162-968-11	CERAMIC CHIP 0.0047MF	10%	50V	
C629	1-162-968-11	CERAMIC CHIP 0.0047MF	10%	50V	
C632	1-162-638-11	CERAMIC CHIP 1MF		16V	
C633	1-135-071-21	TANTAL. CHIP 0.15MF	20%	35V	
C634	1-162-953-11	CERAMIC CHIP 100PF	5%	50V	
C802	1-130-774-00	FILM 0.33MF	10%	63V	
C803	1-162-970-11	CERAMIC CHIP 0.01MF	10%	25V	
C804	1-162-964-11	CERAMIC CHIP 0.001MF	10%	50V	
C806	1-162-964-11	CERAMIC CHIP 0.001MF	10%	50V	
C807	1-135-103-00	TANTAL. CHIP 3.3MF	20%	4V	
C808	1-162-638-11	CERAMIC CHIP 1MF		16V	
C809	1-163-038-00	CERAMIC CHIP 0.1MF	25V		
C810	1-162-964-11	CERAMIC CHIP 0.001MF	10%	50V	
C811	1-163-038-00	CERAMIC CHIP 0.1MF	25V		
C812	1-162-953-11	CERAMIC CHIP 100PF	5%	50V	
C813	1-164-149-11	CERAMIC CHIP 36PF	5%	50V	
C814	1-162-942-11	CERAMIC CHIP 12PF	5%	50V	
C816	1-162-970-11	CERAMIC CHIP 0.01MF	10%	25V	
C817	1-135-104-00	TANTAL. CHIP 10MF	20%	4V	
C818	1-162-953-11	CERAMIC CHIP 100PF	5%	50V	
C819	1-162-953-11	CERAMIC CHIP 100PF	5%	50V	
C820	1-162-953-11	CERAMIC CHIP 100PF	5%	50V	
C821	1-162-953-11	CERAMIC CHIP 100PF	5%	50V	

Ref.No.	Part No.	Description			
C822	1-162-953-11	CERAMIC CHIP 100PF	5%	50V	
C823	1-162-953-11	CERAMIC CHIP 100PF	5%	50V	
C824	1-162-953-11	CERAMIC CHIP 100PF	5%	50V	
C825	1-162-962-11	CERAMIC CHIP 470PF	10%	50V	
C826	1-162-953-11	CERAMIC CHIP 100PF	5%	50V	
C827	1-162-953-11	CERAMIC CHIP 100PF	5%	50V	
C828	1-124-576-11	ELECT 220MF	20%	4V	
C829	1-135-103-00	TANTAL. CHIP 3.3MF	20%	4V	
C830	1-162-970-11	CERAMIC CHIP 0.01MF	10%	25V	
CD401	1-577-065-11	FILTER, CERAMIC			
CF1	1-577-030-11	FILTER, CERAMIC			
CF401	1-567-389-11	FILTER, CERAMIC			
CF402	1-567-389-11	FILTER, CERAMIC			
CN1	1-565-073-11	SOCKET, CONNECTOR 16P			
CN2	1-566-385-11	PIN, CONNECTOR 2P			
CN3	1-566-385-11	PIN, CONNECTOR 2P			
CT401	1-141-347-11	CAP, VAR, TRIMMER (CHIP)			
CT402	1-141-347-11	CAP, VAR, TRIMMER (CHIP)			
D1	8-719-101-23	DIODE 1SS123			
D2	8-719-101-23	DIODE 1SS123			
D3	8-719-123-79	DIODE 1SS279			
D4	8-719-123-79	DIODE 1SS279			
D5	8-719-123-79	DIODE 1SS279			
D6	8-719-123-79	DIODE 1SS279			
D7	8-719-123-79	DIODE 1SS279			
D8	8-719-123-79	DIODE 1SS279			
D203	8-713-300-00	DIODE 1T33			
D204	8-713-300-00	DIODE 1T33			
D401	8-713-300-00	DIODE 1T33			
D402	8-713-300-00	DIODE 1T33			
D403	8-713-300-00	DIODE 1T33			
D601	8-719-123-82	DIODE 1SS303			
D602	8-719-106-80	DIODE RDI3M-82			
D604	8-719-123-85	DIODE 1SS304			
D801	8-719-123-85	DIODE 1SS304			
D802	8-719-123-85	DIODE 1SS304			
D803	8-719-123-85	DIODE 1SS304			
D804	8-719-123-85	DIODE 1SS304			
D805	8-719-123-85	DIODE 1SS304			
D806	8-719-800-54	DIODE TLUR122			
D807	8-719-812-33	DIODE TLG123A			
D808	8-719-123-85	DIODE 1SS304			
D809	8-719-123-85	DIODE 1SS304			
D810	8-719-123-85	DIODE 1SS304			
D811	8-719-101-23	DIODE 1SS123			
D812	8-719-123-82	DIODE 1SS303			
D813	8-719-123-85	DIODE 1SS304			
IC401	8-752-011-11	IC CX20111			
IC402	8-759-804-98	IC LA3335M			
IC601	8-759-910-71	IC BA5208AF			
IC801	8-759-140-92	IC UPD1715G-545-22			
IC802	8-759-947-95	IC S-8051HN-CD-S			
IC803	8-759-804-76	IC LA5002M			
IC804	8-759-113-94	IC UPD74HC239G			
J401	1-507-950-21	JACK (SMALL TYPE)(REC OUT)			
J601	1-565-074-11	JACK, OUTER POWER 1P (DC IN 3V)			
J602	1-507-958-31	JACK (HEADPHONE)			

Ref.No.	Part No.	Description
L1	1-410-220-31	INDUCTOR CHIP 220UH
L2	1-410-733-21	INDUCTOR CHIP 0.22UH
L3	1-410-220-31	INDUCTOR CHIP 220UH
L4	1-410-203-51	INDUCTOR CHIP 8.2UH
L5	1-410-191-51	INDUCTOR CHIP 0.82UH
L6	1-410-197-11	INDUCTOR CHIP 2.7UH
L7	1-410-197-11	INDUCTOR CHIP 2.7UH
L9	1-410-200-31	INDUCTOR CHIP 4.7UH
L201	1-410-200-31	INDUCTOR CHIP 4.7UH
L202	1-410-196-11	INDUCTOR CHIP 2.2UH
L203	1-410-186-51	INDUCTOR CHIP 0.33UH
L204	1-410-187-41	INDUCTOR CHIP 0.39UH
L205	1-410-188-51	INDUCTOR CHIP 0.47UH
L604	1-412-011-31	INDUCTOR CHIP 27UH
L605	1-412-011-31	INDUCTOR CHIP 27UH
LCD801	1-808-270-11	DISPLAY PANEL, LIQUID CRYSTAL
Q1	8-729-123-86	TRANSISTOR 2SK238-K16
Q2	8-729-123-86	TRANSISTOR 2SK238-K16
Q3	8-769-401-59	TRANSISTOR 2SK613-3
Q4	8-769-401-59	TRANSISTOR 2SK613-3
Q5	8-769-401-59	TRANSISTOR 2SK613-3
Q6	8-729-109-42	TRANSISTOR 2SK94-X2
Q7	8-729-117-72	TRANSISTOR 2SC4178
Q201	8-729-117-72	TRANSISTOR 2SC4178
Q202	8-729-117-72	TRANSISTOR 2SC4178
Q203	8-729-117-72	TRANSISTOR 2SC4178
Q205	8-729-117-72	TRANSISTOR 2SC4178
Q401	8-729-905-61	TRANSISTOR DTC124EU
Q402	8-729-107-45	TRANSISTOR 2SC3624A-L16
Q403	8-729-107-45	TRANSISTOR 2SC3624A-L16
Q405	8-729-402-75	TRANSISTOR XN5501
Q406	8-729-800-36	TRANSISTOR 2SD1048
Q407	8-729-117-32	TRANSISTOR 2SC4177
Q408	8-729-117-32	TRANSISTOR 2SC4177
Q409	8-729-402-16	TRANSISTOR XN4608
Q410	8-729-117-32	TRANSISTOR 2SC4177
Q411	8-729-117-32	TRANSISTOR 2SC4177
Q412	8-729-905-61	TRANSISTOR DTC124EU
Q413	8-729-905-61	TRANSISTOR DTC124EU
Q420	8-729-123-86	TRANSISTOR 2SK238-K16
Q602	8-729-117-32	TRANSISTOR 2SC4177
Q603	8-729-117-32	TRANSISTOR 2SC4177
Q605	8-729-402-16	TRANSISTOR XN4608
Q606	8-729-800-36	TRANSISTOR 2SD1048
Q607	8-729-800-36	TRANSISTOR 2SD1048
Q801	8-729-109-42	TRANSISTOR 2SK94-X2
Q802	8-729-117-32	TRANSISTOR 2SC4177
Q804	8-729-117-32	TRANSISTOR 2SC4177
Q805	8-729-905-99	TRANSISTOR DTC114TU
Q806	8-729-905-99	TRANSISTOR DTC114TU
Q807	8-729-905-99	TRANSISTOR DTC114TU
Q808	8-729-905-61	TRANSISTOR DTC124EU
Q809	8-729-402-16	TRANSISTOR XN4608
Q811	8-729-800-68	TRANSISTOR 2SB815
Q812	8-729-800-68	TRANSISTOR 2SB815
Q813	8-729-800-68	TRANSISTOR 2SB815
Q814	8-729-800-68	TRANSISTOR 2SB815
Q815	8-729-800-68	TRANSISTOR 2SB815

Ref.No.	Part No.	Description
Q816	8-729-800-68	TRANSISTOR 2SB815
Q817	8-729-109-42	TRANSISTOR 2SK94-X2
Q818	8-729-403-17	TRANSISTOR XN1215
R1	1-216-819-11	METAL GLAZE 680 5% 1/16W
R2	1-216-829-11	METAL GLAZE 4.7K 5% 1/16W
R3	1-216-807-11	METAL GLAZE 68 5% 1/16W
R4	1-216-819-11	METAL GLAZE 680 5% 1/16W
R5	1-216-845-11	METAL GLAZE 100K 5% 1/16W
R6	1-216-864-11	METAL GLAZE 0 5% 1/16W
R7	1-216-864-11	METAL GLAZE 0 5% 1/16W
R8	1-216-797-11	METAL GLAZE 10 5% 1/16W
R9	1-216-820-11	METAL GLAZE 820 5% 1/16W
R10	1-216-819-11	METAL GLAZE 680 5% 1/16W
R11	1-216-829-11	METAL GLAZE 4.7K 5% 1/16W
R12	1-216-821-11	METAL GLAZE 1K 5% 1/16W
R13	1-216-821-11	METAL GLAZE 1K 5% 1/16W
R14	1-216-797-11	METAL GLAZE 10 5% 1/16W
R15	1-216-797-11	METAL GLAZE 10 5% 1/16W
R16	1-216-828-11	METAL GLAZE 3.9K 5% 1/16W
R17	1-216-825-11	METAL GLAZE 2.2K 5% 1/16W
R18	1-216-825-11	METAL GLAZE 2.2K 5% 1/16W
R19	1-216-864-11	METAL GLAZE 0 5% 1/16W
R20	1-216-864-11	METAL GLAZE 0 5% 1/16W
R21	1-216-809-11	METAL GLAZE 100 5% 1/16W
R22	1-216-819-11	METAL GLAZE 680 5% 1/16W
R23	1-216-828-11	METAL GLAZE 3.9K 5% 1/16W
R24	1-216-809-11	METAL GLAZE 100 5% 1/16W
R25	1-216-825-11	METAL GLAZE 2.2K 5% 1/16W
R26	1-216-825-11	METAL GLAZE 2.2K 5% 1/16W
R30	1-216-809-11	METAL GLAZE 100 5% 1/16W
R31	1-216-817-11	METAL GLAZE 470 5% 1/16W
R32	1-216-809-11	METAL GLAZE 100 5% 1/16W
R33	1-216-815-11	METAL GLAZE 330 5% 1/16W
R34	1-216-821-11	METAL GLAZE 1K 5% 1/16W
R35	1-216-837-11	METAL GLAZE 22K 5% 1/16W
R204	1-216-818-11	METAL GLAZE 560 5% 1/16W
R205	1-216-821-11	METAL GLAZE 1K 5% 1/16W
R206	1-216-813-11	METAL GLAZE 220 5% 1/16W
R207	1-216-841-11	METAL GLAZE 47K 5% 1/16W
R208	1-216-864-11	METAL GLAZE 0 5% 1/16W
R209	1-216-843-11	METAL GLAZE 68K 5% 1/16W
R210	1-216-809-11	METAL GLAZE 100 5% 1/16W
R211	1-216-821-11	METAL GLAZE 1K 5% 1/16W
R212	1-216-821-11	METAL GLAZE 1K 5% 1/16W
R213	1-216-836-11	METAL GLAZE 18K 5% 1/16W
R214	1-216-845-11	METAL GLAZE 100K 5% 1/16W
R218	1-216-817-11	METAL GLAZE 470 5% 1/16W
R219	1-216-817-11	METAL GLAZE 470 5% 1/16W
R220	1-216-837-11	METAL GLAZE 22K 5% 1/16W
R250	1-216-864-11	METAL GLAZE 0 5% 1/16W
R252	1-216-864-11	METAL GLAZE 0 5% 1/16W
R260	1-216-864-11	METAL GLAZE 0 5% 1/16W
R261	1-216-864-11	METAL GLAZE 0 5% 1/16W
R262	1-216-850-11	METAL GLAZE 270K 5% 1/16W
R263	1-216-851-11	METAL GLAZE 330K 5% 1/16W
R401	1-216-821-11	METAL GLAZE 1K 5% 1/16W
R402	1-216-845-11	METAL GLAZE 100K 5% 1/16W

Ref.No.	Part No.	Description			
R403	1-216-797-11	METAL GLAZE	10	5%	1/16W
R404	1-216-825-11	METAL GLAZE	2.2K	5%	1/16W
R405	1-216-845-11	METAL GLAZE	100K	5%	1/16W
R406	1-216-845-11	METAL GLAZE	100K	5%	1/16W
R407	1-216-811-11	METAL GLAZE	150	5%	1/16W
R409	1-216-864-11	METAL GLAZE	0	5%	1/16W
R410	1-216-833-11	METAL GLAZE	10K	5%	1/16W
R411	1-216-809-11	METAL GLAZE	100	5%	1/16W
R412	1-216-825-11	METAL GLAZE	2.2K	5%	1/16W
R413	1-216-821-11	METAL GLAZE	1K	5%	1/16W
R414	1-216-829-11	METAL GLAZE	4.7K	5%	1/16W
R415	1-216-821-11	METAL GLAZE	1K	5%	1/16W
R416	1-216-833-11	METAL GLAZE	10K	5%	1/16W
R417	1-216-817-11	METAL GLAZE	470	5%	1/16W
R418	1-216-841-11	METAL GLAZE	47K	5%	1/16W
R419	1-216-833-11	METAL GLAZE	10K	5%	1/16W
R420	1-216-837-11	METAL GLAZE	22K	5%	1/16W
R421	1-216-821-11	METAL GLAZE	1K	5%	1/16W
R422	1-216-813-11	METAL GLAZE	220	5%	1/16W
R423	1-216-826-11	METAL GLAZE	2.7K	5%	1/16W
R424	1-216-848-11	METAL GLAZE	180K	5%	1/16W
R425	1-216-832-11	METAL GLAZE	8.2K	5%	1/16W
R426	1-216-823-11	METAL GLAZE	1.5K	5%	1/16W
R427	1-216-845-11	METAL GLAZE	100K	5%	1/16W
R428	1-216-845-11	METAL GLAZE	100K	5%	1/16W
R429	1-216-841-11	METAL GLAZE	47K	5%	1/16W
R430	1-216-845-11	METAL GLAZE	100K	5%	1/16W
R431	1-216-809-11	METAL GLAZE	100	5%	1/16W
R432	1-216-840-11	METAL GLAZE	39K	5%	1/16W
R433	1-216-837-11	METAL GLAZE	22K	5%	1/16W
R434	1-216-835-11	METAL GLAZE	15K	5%	1/16W
R437	1-216-839-11	METAL GLAZE	33K	5%	1/16W
R438	1-216-816-11	METAL GLAZE	390	5%	1/16W
R440	1-216-809-11	METAL GLAZE	100	5%	1/16W
R441	1-216-821-11	METAL GLAZE	1K	5%	1/16W
R442	1-216-845-11	METAL GLAZE	100K	5%	1/16W
R443	1-216-845-11	METAL GLAZE	100K	5%	1/16W
R450	1-216-296-00	METAL GLAZE	0	5%	1/8W
R602	1-216-864-11	METAL GLAZE	0	5%	1/16W
R603	1-216-845-11	METAL GLAZE	100K	5%	1/16W
R604	1-216-818-11	METAL GLAZE	560	5%	1/16W
R605	1-216-818-11	METAL GLAZE	560	5%	1/16W
R606	1-216-829-11	METAL GLAZE	4.7K	5%	1/16W
R607	1-216-829-11	METAL GLAZE	4.7K	5%	1/16W
R608	1-216-842-11	METAL GLAZE	56K	5%	1/16W
R609	1-216-013-00	METAL GLAZE	33	5%	1/10W
R610	1-216-013-00	METAL GLAZE	33	5%	1/10W
R612	1-216-797-11	METAL GLAZE	10	5%	1/16W
R613	1-216-843-11	METAL GLAZE	68K	5%	1/16W
R614	1-216-845-11	METAL GLAZE	100K	5%	1/16W
R615	1-216-845-11	METAL GLAZE	100K	5%	1/16W
R616	1-216-821-11	METAL GLAZE	1K	5%	1/16W
R620	1-216-833-11	METAL GLAZE	10K	5%	1/16W
R621	1-216-833-11	METAL GLAZE	10K	5%	1/16W
R622	1-216-825-11	METAL GLAZE	2.2K	5%	1/16W
R625	1-216-833-11	METAL GLAZE	10K	5%	1/16W
R626	1-216-799-11	METAL GLAZE	15	5%	1/16W

Ref.No.	Part No.	Description			
R627	1-216-830-11	METAL GLAZE	5.6K	5%	1/16W
R628	1-216-296-11	METAL GLAZE	0	5%	1/16W
R629	1-216-296-11	METAL GLAZE	0	5%	1/16W
R630	1-216-296-11	METAL GLAZE	0	5%	1/16W
R631	1-216-296-11	METAL GLAZE	0	5%	1/16W
R801	1-216-834-11	METAL GLAZE	12K	5%	1/16W
R802	1-216-832-11	METAL GLAZE	8.2K	5%	1/16W
R803	1-216-831-11	METAL GLAZE	6.8K	5%	1/16W
R804	1-216-832-11	METAL GLAZE	8.2K	5%	1/16W
R810	1-216-821-11	METAL GLAZE	1K	5%	1/16W
R811	1-216-857-11	METAL GLAZE	1M	5%	1/16W
R812	1-216-821-11	METAL GLAZE	1K	5%	1/16W
R813	1-216-820-11	METAL GLAZE	820	5%	1/16W
R818	1-216-805-11	METAL GLAZE	47	5%	1/16W
R819	1-216-857-11	METAL GLAZE	1M	5%	1/16W
R820	1-216-833-11	METAL GLAZE	10K	5%	1/16W
R821	1-216-833-11	METAL GLAZE	10K	5%	1/16W
R822	1-216-833-11	METAL GLAZE	10K	5%	1/16W
R824	1-216-833-11	METAL GLAZE	10K	5%	1/16W
R825	1-216-825-11	METAL GLAZE	2.2K	5%	1/16W
R826	1-216-833-11	METAL GLAZE	10K	5%	1/16W
R827	1-216-833-11	METAL GLAZE	10K	5%	1/16W
R828	1-216-825-11	METAL GLAZE	2.2K	5%	1/16W
R829	1-216-833-11	METAL GLAZE	10K	5%	1/16W
R831	1-216-833-11	METAL GLAZE	10K	5%	1/16W
R833	1-216-828-11	METAL GLAZE	3.9K	5%	1/16W
R834	1-216-840-11	METAL GLAZE	39K	5%	1/16W
R835	1-216-813-11	METAL GLAZE	220	5%	1/16W
R837	1-216-829-11	METAL GLAZE	4.7K	5%	1/16W
R838	1-216-797-11	METAL GLAZE	10	5%	1/16W
R839	1-216-825-11	METAL GLAZE	2.2K	5%	1/16W
R840	1-216-825-11	METAL GLAZE	2.2K	5%	1/16W
R841	1-216-825-11	METAL GLAZE	2.2K	5%	1/16W
R842	1-216-825-11	METAL GLAZE	2.2K	5%	1/16W
R843	1-216-825-11	METAL GLAZE	2.2K	5%	1/16W
R844	1-216-825-11	METAL GLAZE	2.2K	5%	1/16W
R845	1-216-833-11	METAL GLAZE	10K	5%	1/16W
R846	1-216-825-11	METAL GLAZE	2.2K	5%	1/16W
R847	1-216-825-11	METAL GLAZE	2.2K	5%	1/16W
R848	1-249-417-11	RES. CARBON	1K	5%	1/4W
R849	1-216-833-11	METAL GLAZE	10K	5%	1/16W
R888	1-216-295-00	METAL GLAZE	0	5%	1/10W
RV201	1-237-146-21	RES. ADJ, METAL GLAZE	220K		
RV202	1-237-146-21	RES. ADJ, METAL GLAZE	220K		
RV401	1-237-119-11	RES. ADJ, METAL GLAZE	22K		
RV601	1-237-997-11	RES. VAR, CARBON	20K/20K (VOLUME)		
S1	1-570-114-11	SWITCH, SLIDE (SENS)			
S601	1-570-114-11	SWITCH, SLIDE (TONE)			
S801	1-570-675-11	SWITCH, SLIDE (MW CH STEP)			
S802	1-571-385-11	SWITCH, KEY BOARD (LIGHT)			
S803	1-570-675-11	SWITCH, SLIDE (MAIN POWER)			
SP601	1-503-842-11	SPEAKER			
T1	1-426-345-11	TRANSFORMER, HIGH FREQUENCY			
T2	1-426-357-11	TRANSFORMER, RF			
T3	1-404-780-11	TRANSFORMER, 1F			
T4	1-404-779-11	TRANSFORMER, 1F			

Ref.No.	Part No.	Description
T5	1-404-778-11	TRANSFORMER, IF
T201	1-406-271-11	COIL (OSC)
T202	1-406-270-11	COIL (OSC)
T401	1-459-828-11	COIL (WITH CORE)
T402	1-459-829-11	COIL (WITH CORE)
T403	1-459-827-11	COIL (WITH CORE)
T601	1-449-021-21	TRANSFORMER, DC-DC CONVERTER
XF1	1-567-987-11	FILTER, CRYSTAL
XT201	1-567-986-11	VIBRATOR, CRYSTAL (55.4MHz)
XT801	1-567-769-11	VIBRATOR, CRYSTAL (75kHz)

ACCESSORY & PACKING MATERIAL

A-3642-002-A	COUPLER ASSY
△1-463-959-11	(Canadian).....ADAPTOR, AC (AC-302)
△1-463-960-11	(UK).....ADAPTOR, AC (AC-303)
△1-463-961-11	(US).....ADAPTOR, AC (AC-301)
△1-463-976-11	(AEP TYPE1-2/3-1).....ADAPTOR, AC (AC-304)
△1-463-977-11	(E TYPE1-1/1-2/2,Saudi Arabia AEP TYPE1-1/2/3-2).....ADAPTOR, AC (AC-301)
△1-506-444-11	(Canadian).....ADAPTOR, CONVERSION
△1-506-409-11	(AEP TYPE1-2/3-1).....ADAPTOR, CONVERSION
△1-565-250-11	(US,Saudi Arabia E TYPE1-1/1-2/2 AEP TYPE1-1/2/3-2)....PLUG, CONVERSION 2P
3-893-708-01	BELT, CARRYING
3-893-726-01	COLLAR, BELT
3-893-730-01	BRACKET, BELT
3-893-802-04	(US,Canadian,E TYPE1-1/1-2) ...BOOK, GUIDE, WAVE
3-887-285-07	(Saudi Arabia,E TYPE2)....BOOK, GUIDE, WAVE
3-899-537-01	CASE (SOFT), CARRYING
3-899-562-01	INDIVIDUAL CARTON
3-899-565-01	CASE (HARD), CARRYING
*3-899-566-01	CUSHION (B)
3-899-571-01	NUT (M2.6), PLATE
*3-899-572-01	(Canadian,AEP TYPE1-2/3-1,UK)....BLIND, CASE
*3-899-572-11	(US,Saudi Arabia,Australian E TYPE1-1/1-2/2 AEP TYPE1-1/2/3-2).....BLIND, CASE
3-990-135-11	(E,Saudi Arabia).....MANUAL, INSTRUCTION
3-990-135-21	(US,Canadian).....MANUAL, INSTRUCTION
3-990-135-31	(Canadian).....MANUAL, INSTRUCTION
3-990-135-41	(AEP TYPE1-1/1-2/3-1)....MANUAL, INSTRUCTION
7-621-662-40	SCREW +RK 2.6X10
7-624-109-04	STOP RING 5.0, TYPE -E
8-952-321-92	EARPHONE MDR-E434/C SET

The components identified by mark △ are critical for safety. Replace only with part number specified.

Les composants identifiés par une marque △ sont critiques pour la sécurité. Ne les remplacer que par une pièce portant le numéro spécifié.

SECTION 9 ANTENNA MODULE (AN-101)

NOTE:

- The mechanical parts with no reference number in the exploded views are not supplied.
- The construction parts of an assembled part are indicated with a collation number in the remark column.
- Items marked "*" are not stocked since they are seldom required for routine service. Some delay should be anticipated when ordering these items.
- Due to standardization, parts with part number suffix -XX and -X may be different from the parts specified in the components used on the set.

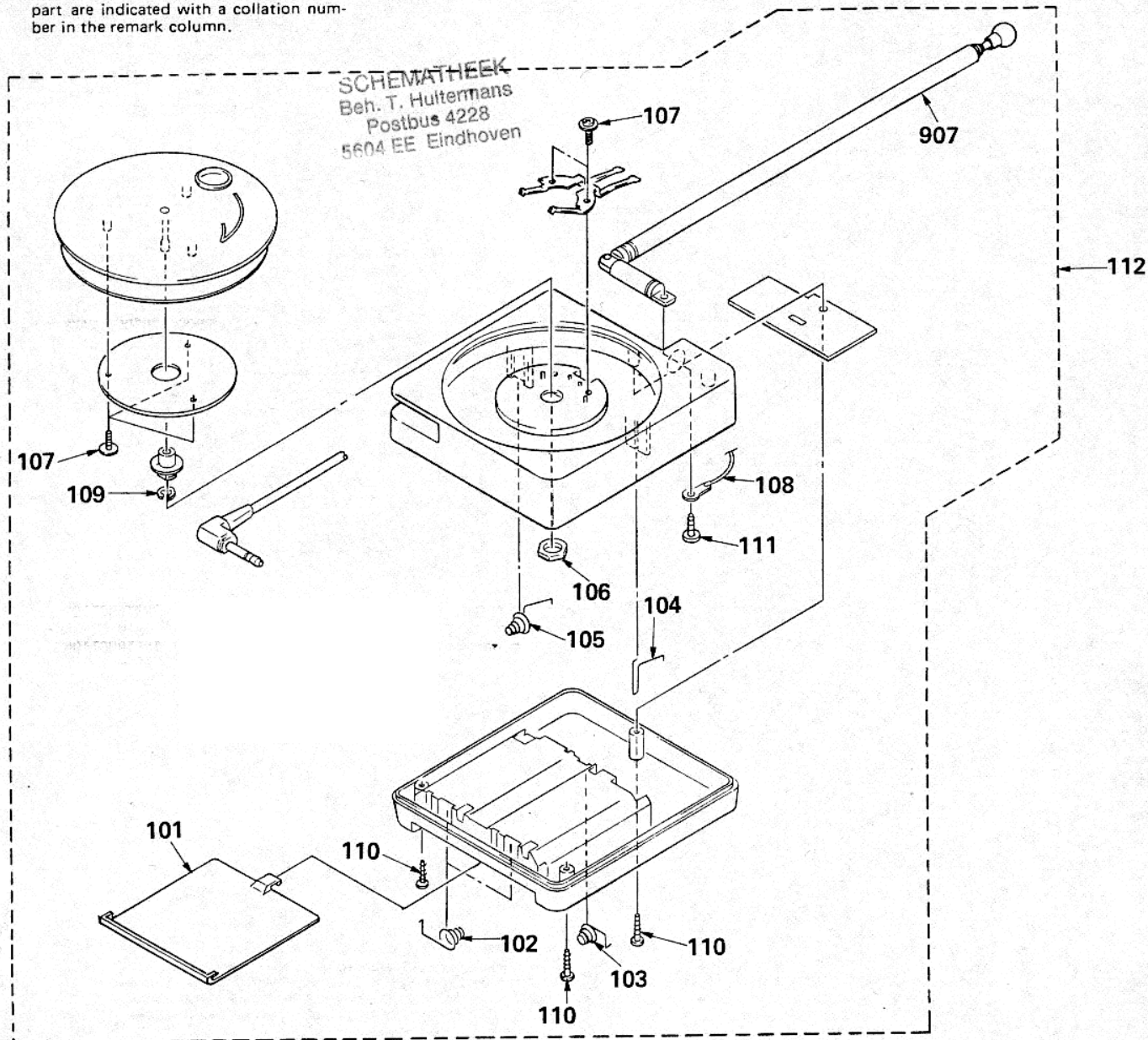

No.	Part No.	Description	Remarks
101	3-899-544-01	LID, BATTERY CASE	
102	3-894-723-01	SPRING (B)	
103	3-894-717-01	SPRING (A)	
104	3-899-542-01	TERMINAL (-), BATTERY	
105	3-899-541-01	TERMINAL (+), BATTERY	
106	3-897-115-01	NUT, VOLUME	
107	3-318-201-31	SCREW (B) (1.4X5), TAPPING	

No.	Part No.	Description	Remarks
108	7-623-508-01	LUG, 3	
109	7-624-104-04	STOP RING 2.0, TYPE -E	
110	7-685-105-19	SCREW +P 2X8 TYPE2 SLIT	
111	7-685-646-79	SCREW +BTP 3X8 TYPE2 N-S	
112	A-3641-193-A	ANTENNA ASSY	
907	1-501-400-11	ANTENNA, TELESCOPIC	